

SPEED HUMP (DUTCH DESIGN)

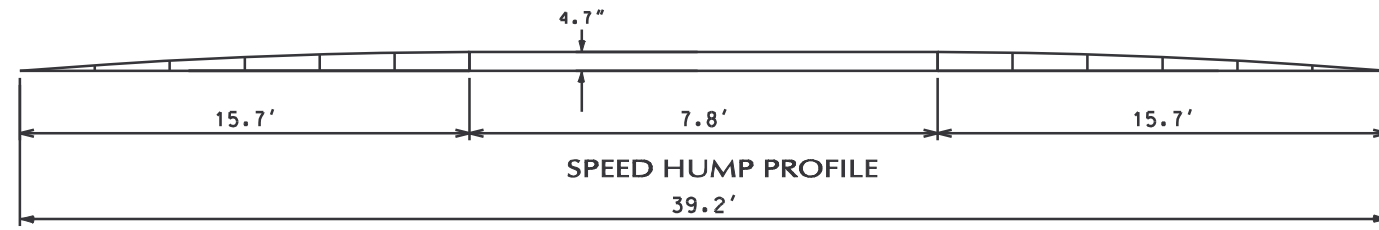

ROAD HUMP SIGNING

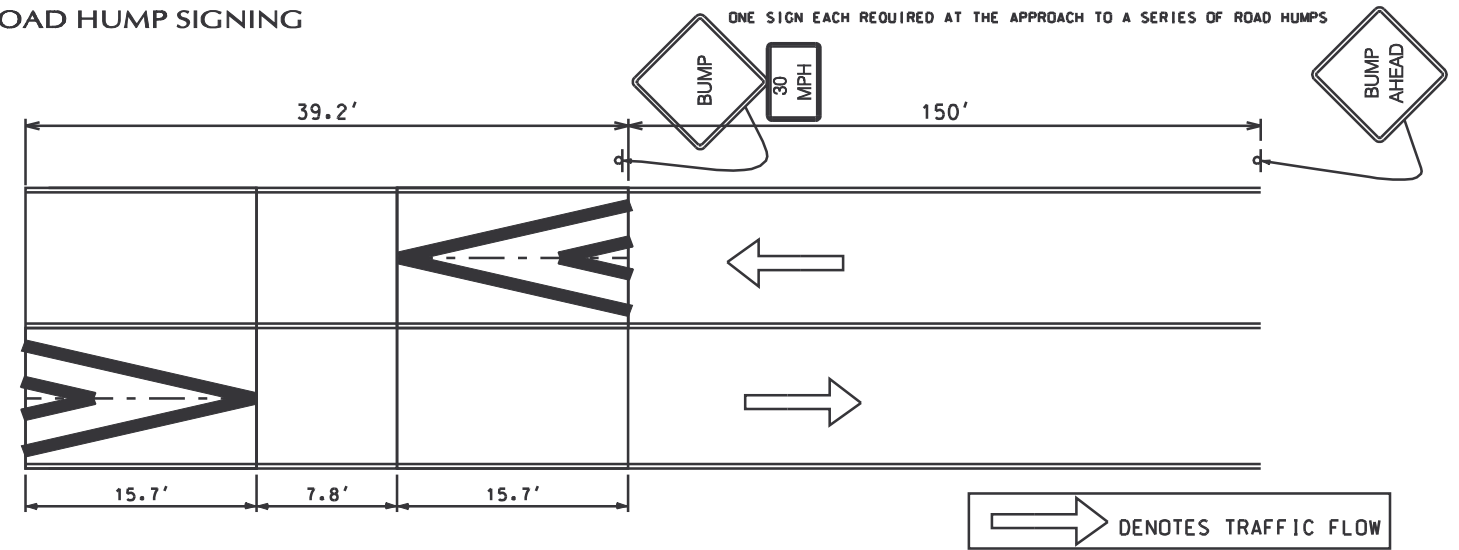

SEMINOLE SPEED HUMP

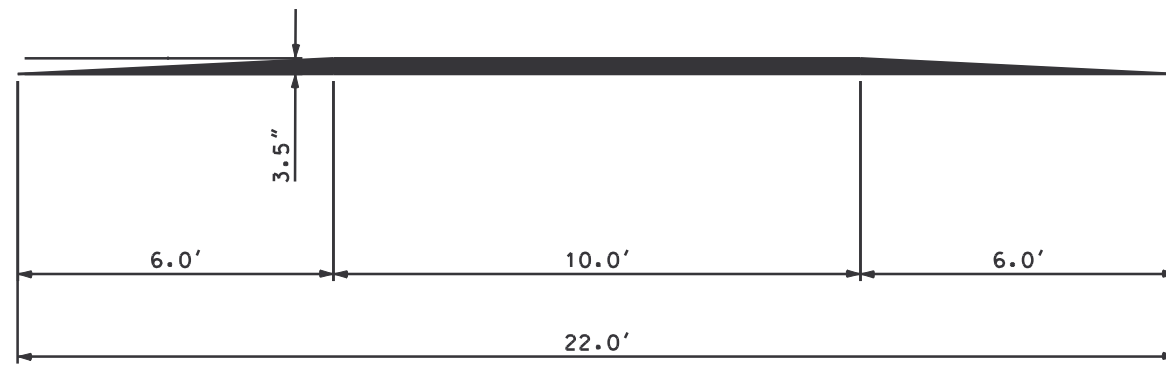

ROAD HUMP SIGNING

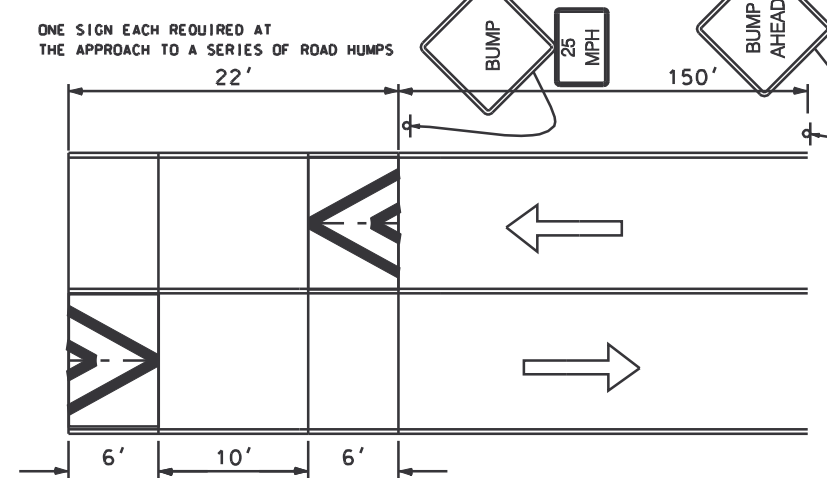

ROAD HUMP PAVEMENT MARKINGS

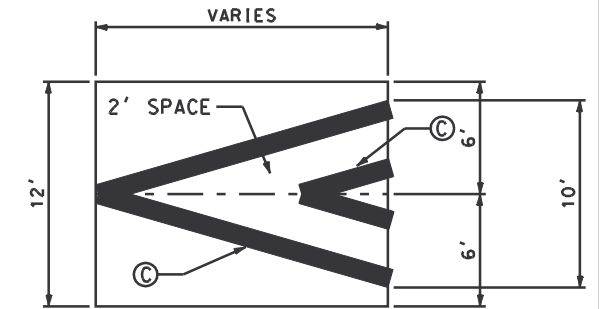

I.T.E. SPEED HUMP

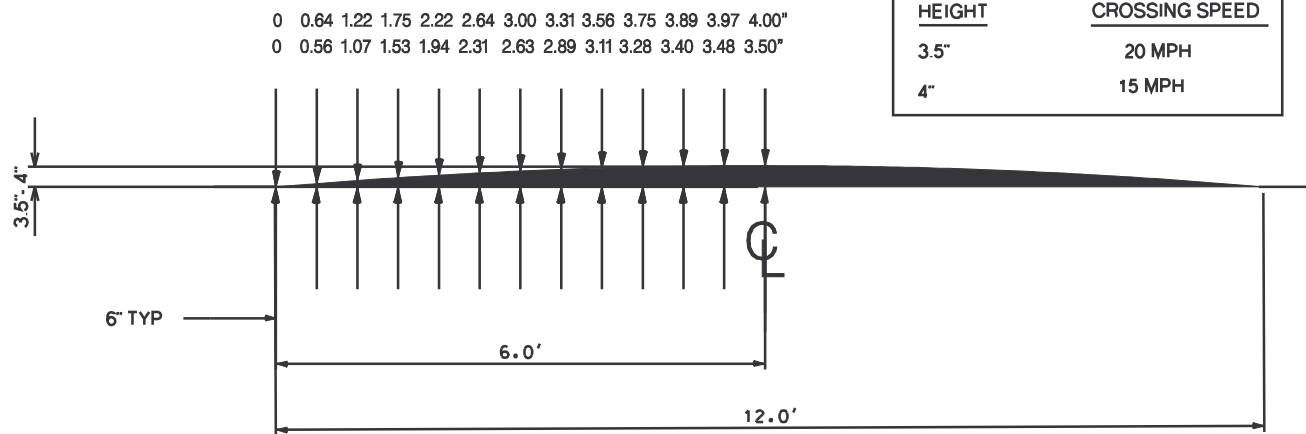

LEGEND:

HEIGHT	CROSSING SPEED
3.5"	20 MPH
4"	15 MPH

ROAD HUMP SIGNING

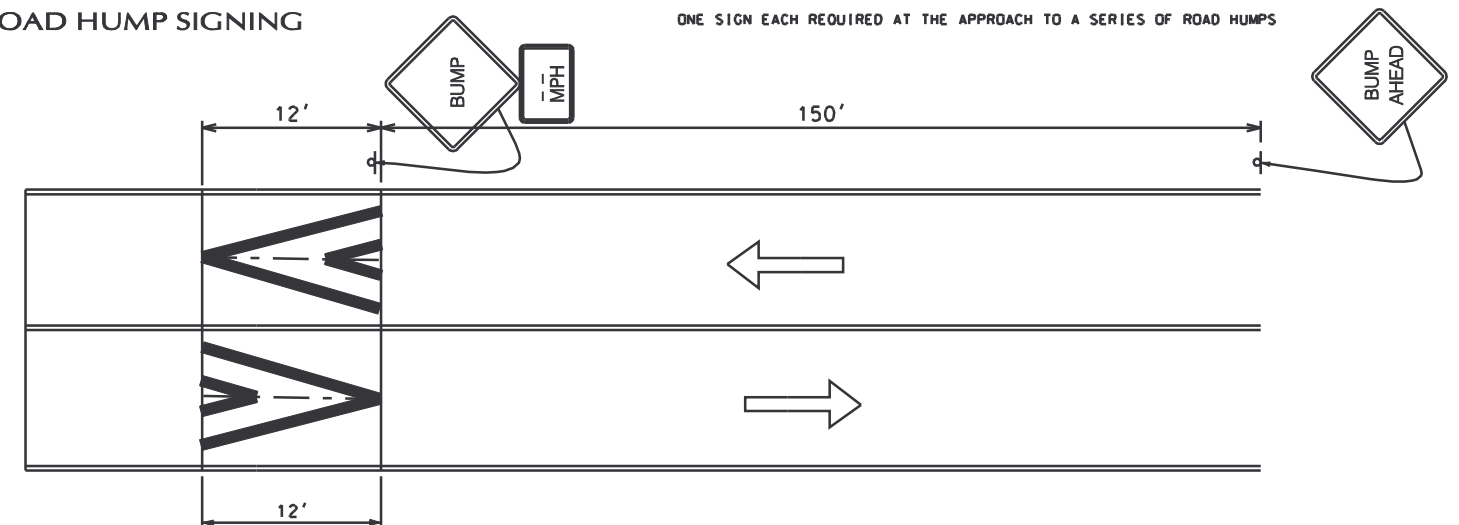

COORDINATION WITH STREET GEOMETRY

A THOROUGH ON-SITE ANALYSIS OF ROADWAY GEOMETRICS SHOULD BE PERFORMED TO ENSURE THAT SPEED HUMPS WILL NOT BE INTRODUCED AT A CRITICAL POINT IN THE ROADWAY SYSTEM. E.G. A SEVERE COMBINATION OF HORIZONTAL, VERTICAL CURVATURE AND / OR STREET GRADIENT.

COORDINATION WITH TRAFFIC OPERATIONS

SPEED HUMPS SHOULD NOT BE INSTALLED WITHIN 400' FT. OF A TRAFFIC SIGNAL OR STOP SIGN OR WITHIN AN INTERSECTION OR DRIVEWAY. MIN. DISTANCE BETWEEN ROAD HUMPS IS 400' AND THE MAXIMUM SHOULD BE 800'. TO BE CONSTRUCTED ONLY WHEN APPROVED BY COUNTY ENGINEER.

CONSTRUCTION PROCEDURES

IT IS RECOMMENDED THAT A TEMPLATE BE CONSTRUCTED TO VERIFY THE ACCURACY OF THE HUMP PROFILE AND TO ENSURE THAT THE DESIRED VERTICAL DIMENSIONS ARE ATTAINED WITHIN REASONABLE TOLERANCES (NORMALLY ONE-HALF INCH OR LESS, PROVIDED THE HUMP DOES NOT EXCEED 4 INCHES). IF THE PROFILE IS INCORRECT, HUMP CHARACTERISTICS WILL BE CHANGED THAT MIGHT IMPACT TRAFFIC SAFETY OR CREATE INEFFECTIVE SPEED CONTROL.

IT IS RECOMMENDED THAT THE ROAD SURFACE BE EXCAVATED AT TAPERING EDGES TO PREVENT SPALLING. HUMPS MAY BE INSTALLED IN TWO LIFTS TO IMPROVE ACCURACY AND SHAPE.

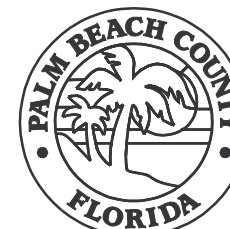

PALM BEACH COUNTY, FLORIDA
TRAFFIC DIVISION
TYPICAL

ROAD HUMP DETAILS

BOGDAN T. PIORKOWSKI REGISTERED ENGINEER		DAN I. WEISBERG TRAFFIC DIRECTOR	
NAME	DATE	SCALE	CONTRACT NO.
CGT	1-27-2004	N.T.S.	
DRAWN BY		DRAWING	T-P-06-001
TRACED BY		CHECKED BY	