

PALM BEACH COUNTY
BOARD OF COUNTY COMMISSIONERS

AGENDA ITEM SUMMARY

Meeting Date: March 15, 2011 Consent Regular
Submitted By: Department of Airports Workshop Public Hearing

I. EXECUTIVE BRIEF

Motion and Title: Staff recommends motion to receive and file: Two (2) original Agreements for the Department of Airports.

A. General Aeronautical Services Permit with Palm Beach Delivery, Inc. d/b/a Yankee Express, commencing 10/1/2010, expiring 9/30/2011, renewed automatically on year-to-year basis (10/1 through 9/30). **(AH)**

B. Second Amendment to Airline-Airport Use and Lease Agreement with jetBlue Airways Corporation replacing Exhibits "B" and "D" to R-2007-0272 increasing hold room area and adding an additional gate. **(AH)**

Summary: Delegation of authority for execution of the standard County agreements above was approved by the BCC in R-2006-1906 and R-2010-0708. Countywide

Background and Justification: N/A

Attachments: Two (2) Standard Agreements for the Department of Airports

Recommended By:  2/14/11
Department Head Date

Approved By:  2/19/11
County Administrator Date

GENERAL AERONAUTICAL SERVICES PERMIT

THIS GENERAL AERONAUTICAL SERVICES PERMIT (this "Permit") is made and entered into JAN 31 2011 by and between Palm Beach County, a political subdivision of the State of Florida ("County"), and Palm Beach Delivery, Inc. d/b/a Yankee Express, a Florida corporation, having its office and principal place of business at 1000 PBIA Box 129, West Palm Beach, Florida 33406, ("Permittee").

WITNESSETH:

WHEREAS, County, by and through its Department of Airports (the "Department"), owns and operates Palm Beach International Airport, located in Palm Beach County, Florida (the "Airport"); and

WHEREAS, Permittee desires to provide certain general aeronautical support services to air carriers operating at the Airport, or to other Airport tenants, on a non-exclusive basis, in common with others authorized to do so; and

WHEREAS, Permittee has filed a completed application with the Department and has requested to enter into this Permit; and

WHEREAS, Resolution No. R-2010-0708, adopted by the Board on May 4, 2010, authorizes the Department, on behalf of County, to enter into this Permit.

NOW, THEREFORE, in consideration of the premises and of the mutual covenants herein contained, and for such other good and valuable consideration, the receipt of which the parties hereby expressly acknowledge, the parties hereto covenant and agree to the following terms and conditions.

ARTICLE 1
RECITALS

The foregoing recitals are true and correct and are hereby incorporated herein by reference.

ARTICLE 2
DEFINITIONS

The following terms set forth below, when used in this Permit, shall be defined as follows:

2.01 "Aircraft and Equipment Maintenance Service" means repair and maintenance of aircraft, and the repair, fueling and maintenance of ramp equipment, which shall be limited to areas approved in advance in writing by the Department.

2.02 "Aircraft Interior Cleaning and Waste Disposal Service" means providing personnel, equipment and material to clean the interior of Aircraft.

2.03 "Aircraft Ramp Service" means guiding aircraft in and out of aircraft loading and unloading positions; placing in position and operating passenger, baggage and cargo loading and

unloading devices, as required for the safe and efficient loading and unloading of passengers, baggage and cargo to and from aircraft; performing loading and unloading of passengers, baggage and cargo to and from aircraft; providing utility services to aircraft; towing aircraft; delivering aircraft cargo, baggage and mail to and from aircraft to locations on the Airport; and fueling of aircraft.

2.04 "Airline-Airport Use and Lease Agreement" means the then current Airline-Airport Use and Lease Agreement approved by the Board. As of the date of this Permit, the most current version of the Airline-Airport Use and Lease Agreement was approved pursuant to Resolution No. R-2006-1906.

2.05 "Airline Ticketing and Boarding Service" means the processing of passengers, including ticketing, checking-in, boarding and unboarding of air passengers and their baggage.

2.06 "Airport" means the Palm Beach International Airport located in Palm Beach County, Florida.

2.07 "Airport Rules and Regulations" means the Palm Beach County Airport Rules and Regulations adopted by Resolution No. R-98-220, as now or hereafter amended, and any successor ordinance or resolution regulating activities or operations on the Airport.

2.08 "Annual Permit Fee" has the meaning set forth in Section 5.01(B).

2.09 "Authorized Aeronautical Services" means those aeronautical support services set forth in Section 4.01.

2.10 "Baggage Delivery Service" means handling and transportation between the Airport and a passenger's location, of delayed, misplaced or misrouted baggage or other articles of the passengers of contracting air carriers or aircraft operators.

2.11 "Board" means the Board of County Commissioners of Palm Beach County, Florida.

2.12 "Bond Resolution" means the Palm Beach County Airport System Revenue Bond Resolution dated April 3, 1984 (R-84-427), as amended and supplemented, which is hereby incorporated herein by reference and made a part hereof.

2.13 "Commencement Date" has the meaning set forth in Article 3.

2.14 "Contract Year" means the period of twelve (12) consecutive months ending with the last day of September of each year.

2.15 "Contracted Flights" has the meaning set forth in Section 6.02(E).

2.16 "Department" means the Palm Beach County Department of Airports.

2.17 "Director" means the Director or Acting Director of the Department of Airports.

2.18 "Effective Date" means the date that this Permit is approved by signed by the parties hereto.

2.19 "Environmental Laws" has the meaning set forth in Section 14.04.

2.20 "FAA" means the Federal Aviation Administration.

2.21 "Facility Usage Charges" has the meaning set forth in the Section 5.03.

2.22 "Federal Inspection Services (FIS) Facility" means that portion of Building 1000 at the Airport designated for U.S. Customs facilities.

2.23 "Gross Revenues" means all revenues paid or payable to Permittee for the provision of services in, on, from or about the Airport pursuant to this Permit, including, without limitation, the Authorized Aeronautical Services. Notwithstanding the foregoing, Gross Revenues shall not include any revenues derived from providing Authorized Aeronautical Services to Signatory Airlines, or sales taxes or similar excise taxes, which are separately stated and collected from Permittee's customers.

2.24 "Initial Term" has the meaning set forth in Article 3.

2.25 "Insurance Requirements" has the meaning set forth in Article 7.

2.26 "Monthly Report" has the meaning set forth in Section 5.04.

2.27 "Non-Signatory Airline" means any airline that is not considered a Signatory Airline for purposes of the Airline-Airport Use and Lease Agreement.

2.28 "Port of Entry Building" means Building 120 at the Airport, utilized for U.S. Customs facilities.

2.29 "Porter Assistance Service" means handling and transportation, through the use of porters, of baggage and other articles of the passengers of contracting air carriers or aircraft operators, upon request of the passenger, in public access areas of the Port of Entry Building and the Terminal, exclusive of the FIS Facility, as designated and approved by the Department.

2.30 "Renewal Term" has the meaning set forth in Article 3.

2.31 "Risk Management Department" means the Palm Beach County Risk Management Department.

2.32 "Service Fee" has the meaning set forth in Section 5.02.

2.33 "Signatory Airline" has the meaning set forth in the Airline-Airport Use and Lease Agreement.

2.34 "Term" has the meaning set forth in Article 3.

2.35 "Terminal" means the commercial passenger terminal located in Building 1000 at the Airport.

2.36 "TSA" means the Transportation Security Administration or any successor agency responsible for airport security.

2.37 "Use Agreement" has the meaning set forth in Section 5.03.

ARTICLE 3 **COMMENCEMENT DATE AND TERM OF AGREEMENT**

The term of this Permit shall commence on October 1, 2010, (the "Commencement Date") and expire on September 30, 2011, (the "Initial Term"). This Permit shall be automatically renewed on a year-to-year basis (October 1st through September 30th) thereafter upon the expiration of the then current term (the "Renewal Term"); provided that: (1) Permittee is not in violation of this Permit; and (2) neither party has provided a notice to the other party, with the Department acting on behalf of County, by at least thirty (30) days advance written notice, of its desire or intent to terminate or not renew this Permit. The Initial Term and each Renewal Term are collectively referred to as the "Term".

ARTICLE 4
PRIVILEGES AND AUTHORIZED SERVICES

4.01 Authorized Aeronautical Services. County hereby authorizes Permittee to provide, on a non-exclusive basis, under written contract with Signatory Airlines, Non-Signatory Airlines, or Airport tenants serving the Airport and having validly executed agreements with County, the following aeronautical support services:

- A. Aircraft Ramp Service
- B. Aircraft and Equipment Maintenance Service
- C. Aircraft Interior Cleaning and Waste Disposal Service
- D. Porter Assistance Service
- E. Baggage Delivery Service
- F. Airline Ticketing and Boarding Service

Permittee shall not provide any other services whatsoever at the Airport, including, but not limited to, other aeronautical support services, without the prior written consent of County, which may be granted or withheld in County's sole and absolute discretion.

4.02 Description of General Privileges, Uses and Rights. County hereby grants to Permittee, the following non-exclusive general privileges, uses and rights, all of which shall be subject to the terms, conditions and covenants hereinafter set forth below:

- A. The general use, in common with others, of all public Airport facilities and improvements in connection with its operations hereunder. For the purpose of this Permit, "public Airport facilities" shall include all necessary roadways, sidewalks, or other public facilities appurtenant to the Airport, not specifically leased to or under the contractual control of others.
- B. The right of ingress to and egress from the Terminal over and across public roadways serving the Airport for Permittee, its agents and employees, patrons and invitees, suppliers of service and furnishers of material, if any. Said right shall be subject to such laws, rules, regulations and orders as now or may hereafter have application at the Airport.

Nothing contained in this Section 4.02 shall be construed to grant to Permittee the right to use any space or area, improved or unimproved, which is leased to a third party.

ARTICLE 5
FEES, CHARGES AND REPORTS

5.01 Permit Fees.

- A. Permittee shall pay a non-refundable application fee of Two Hundred Fifty Dollars (\$250.00) with submission of Permittee's application for this Permit. In the event this Permit expires or is otherwise terminated, Permittee shall be required to pay an additional application fee at the then current rate.

B. Permittee shall pay an annual permit fee of Two Hundred Fifty Dollars (\$250.00) ("Annual Permit Fee"). The Annual Permit Fee shall be paid on or before October 1 of each year, without demand, deduction or setoff, throughout the Term of this Permit. Payment of the Annual Permit Fee shall be in addition to payment of the Service Fee as provided in Section 5.02 and Facility Usage Charges as provided in Section 5.03.

5.02 Service Fee. Permittee shall pay to County seven percent (7%) of monthly Gross Revenues, together with applicable sales taxes thereon ("Service Fee"). The Service Fee shall be paid to County on or before the fifteenth (15th) day of each and every month, without demand, deduction or setoff, throughout the Term of this Permit.

5.03 Facility Usage Charges. Permittee shall pay to County reasonable and non-discriminatory fees and charges ("Facility Usage Charges") as set forth in the then current Airline-Airport Use and Lease Agreement, for the use of any Airport facilities and/or equipment, including, but not limited to, baggage makeup areas and devices and passenger loading bridges. Notwithstanding the foregoing, County may require Permittee to enter into a separate agreement for the use of Airport facilities and equipment ("Use Agreement"). Except as otherwise provided in any Use Agreement with County, Facility Usage Charges shall be paid to County on or before the fifteenth (15th) day of each and every month, without demand, deduction or setoff, throughout the Term of this Permit.

5.04 Monthly Report. On or before the fifteenth (15th) day of each month throughout the Term of this Permit, Permittee shall submit to County, in a form and in detail satisfactory to County, a written report that: (1) details Gross Revenues for the preceding month; (2) details Service Fees payable to County for the preceding month; (3) details any Facility Usage Charges payable to County in connection with services provided by Permittee pursuant to Section 4.01(F); (4) separately identifies any exclusions from Gross Revenues; and (5) identifies the airlines, aircraft operators and/or other tenants at the Airport that Permittee provided services for during the preceding month (the "Monthly Report"). The Monthly Report shall be signed by a responsible officer of Permittee, certifying the accuracy of the information contained in the Monthly Report. County may require reports required by this Article 5 to be submitted in an electronic format.

5.05 Payment of Taxes. Permittee shall pay any and all taxes and other costs as may be lawfully assessed against its operations under this Permit. Permittee shall have the right to contest the amount or validity of any tax or assessment payable by its appropriate legal proceedings, but this shall not be deemed or construed in any way as relieving, modifying, or extending Permittee's covenants to pay any such tax or assessment, unless the legal proceedings shall operate to prevent the collection of the tax or assessment. Upon termination of such legal proceedings, Permittee shall pay the amount of any such tax or assessment, or part thereof, as finally determined in such proceedings, the payment of which may have been deferred during the prosecution thereof, together with any costs, fees, interest, penalties, or other liabilities in connection therewith.

5.06 Unpaid Fees and Charges. In the event Permittee fails to make timely payment of any amounts due and payable in accordance with the terms of this Permit, then interest at the rate of one and one half percent (1.5%) per month shall accrue against the delinquent payment(s) from date due until the date payment is received by Department.

5.07 Audit Requirement. On or before December 31 of each year, Permittee shall provide to County an audit report in accordance with the requirements of this Section 5.07 for the preceding Contract Year. The first such audit report shall commence as of the Commencement Date and the last audit report shall cover through Permittee's last day of operation under to this Permit. In the event the Gross Revenues for the preceding Contract Year are Twenty-Five Thousand Dollars (\$25,000) or less, the audit report may be prepared by an employee of Permittee and shall be signed and certified under oath by the chief financial officer of Permittee as being true and correct. In the event the Gross Revenues for the preceding Contract Year are more than Twenty-Five Thousand Dollars (\$25,000), the audit report shall be prepared by an independent Certified Public Accountant, not a regular employee of Permittee, in accordance with Generally Accepted Auditing Standards prescribed by the American Institute of Certified Public Accountants or any successor agency thereto. The audit report shall be in a form acceptable to the Department. The audit report shall include the following:

- A. Schedule of Gross Revenues by month.
- B. Schedule of Service Fees by month.
- C. Schedule of Facility Usage Charges by month (if any).
- D. Schedule of payments made to County by month.
- E. A calculation of the total amount of Service Fees payable to County for the preceding Contract Year.

In the event Permittee is required to submit an audit report prepared by an independent Certified Public Accountant, the audit report shall include an opinion on the required schedules. Failure to deliver an audit report, or delivery of an audit report containing a qualified opinion, an adverse opinion, or a disclaimer of opinion, as defined by the American Institute of Certified Public Accountants or any successor agency thereto, shall be deemed to be a material default of this Permit. If the audit report indicates that the amount due and owing for any Contract Year is greater than the amount paid by Permittee to County during such Contract Year, Permittee shall pay the difference to County with the audit report. If the amount actually paid by Permittee to County during any Contract Year exceeds the amount due and owing for such Contract Year, County shall credit the overpayment in the following order: (1) against any past due amounts owed to County by Permittee, including interest and late fees; (2) against currently outstanding, but not yet due, amounts owed to County by Permittee; (3) against future amounts that will become due during the succeeding Contract Year; and (4) against any other sums payable by Permittee to County. Notwithstanding the foregoing, in the event of an overpayment by Permittee during the last Contract Year, County shall credit the overpayment against any remaining amounts owed to County, including interest and late fees, and refund to Permittee any overpayment amount in excess of the credit.

5.08 Address for Payments. All payments required to be made by Permittee under this Permit shall be made payable to "Palm Beach County." All reports and payments shall be delivered to the following address: Finance Division, Department of Airports, 846 Palm Beach International Airport, West Palm Beach, Florida 33406-1470, or to such other office or address as may be substituted therefor.

5.09 Accounting Records. Permittee shall maintain all books of account and records customarily used in this type of operation, in accordance with Generally Accepted Accounting Practices (GAAP). County, at all times, throughout the Term and for no less than three (3) years following termination of this Permit, shall have the right to audit and examine during normal working hours all such records and books of account relating to Permittee's operations hereunder, provided that Permittee shall not be required to retain such books of account and records for more than three (3) years after the end of each Contract Year of this Permit. Upon County's request for examination of such books of account and records and should the books of account and records be kept at locations other than the Airport, Permittee shall arrange for them to be brought to a location convenient to the auditors for County in order for County to conduct the audits and inspections as set forth in this Article 5. If, as a result of the audit, County determines that Permittee has understated the amounts due to County hereunder by five percent (5%) or more, the entire expense to County of the audit shall be assumed by and be the sole responsibility of Permittee. All amounts due County and reasonable expenses associated with said audit (if any) shall forthwith be paid by Permittee to County, with interest thereon calculated in accordance with Section 5.06 hereof.

5.10 Service Contracts. Upon County's request, Permittee shall provide to County legible, written copies of any and all contracts entered into between Permittee and any other person or entity for the provision of services under this Permit ("Service Contracts"), including, but not limited to, airlines serving the Airport. Permittee shall also provide to County copies of any and all renewals, modifications, amendments and cancellations to the Service Contracts.

5.11 Adjustment of Fees and Charges. Permittee acknowledges and agrees that the fees and charges payable hereunder may be modified from time to time and that Permittee shall be responsible for payment of such modified fees without formal amendment to this Permit.

ARTICLE 6 **OBLIGATIONS OF PERMITTEE**

6.01 Maintenance of Facilities and Equipment.

- A. Permittee shall, at its sole cost and expense, maintain all facilities and equipment provided by County to Permittee for use at the Airport in carrying out the Authorized Aeronautical Services, in good and fit condition consistent with good business practice and in accordance with all applicable laws, regulations and rules of any government agency. Permittee shall repair any damage to the Airport caused by its employees, patrons, invitees, suppliers of service or furnishers of material, or any other persons whomsoever, and all damages caused by or resulting from or in any way arising out of Permittee's operations thereon. Permittee

hereby agrees that it shall abide by the decision of County with respect to any and all maintenance or repair requirements. County shall be the sole judge of Permittee's performance under this Section 6.01(A), as to the quality of maintenance or repair. Upon written notice by County to Permittee, Permittee shall perform the required maintenance or repair in accordance with County's decision. If Permittee has not made a good faith effort, as determined by County, to begin to perform the required maintenance or repair within ten (10) days of the date of the written notice, and to diligently pursue the same to completion, County shall have the right to perform the maintenance or repair, and Permittee hereby expressly agrees that it shall fully assume and be liable to County for payment of the costs therefor, plus a twenty-five percent (25%) administrative overhead. Permittee shall pay all costs incurred by County, plus the administrative overhead, within thirty (30) days of the date of County's invoice.

- B. Permittee shall maintain its equipment utilized at the Airport in good condition and repair. In addition, any equipment utilized within the public areas of the Terminal shall be in a safe, neat and clean condition at all times, including, but not limited to, carts used to transport passenger luggage and wheelchairs. County may require Permittee to remove, repair or replace any equipment from the Airport that is in an unsafe or unsightly condition upon written notice. In the event Permittee fails to remove, repair or replace the equipment as required by County's notice within three (3) business days of the date of the notice, Permittee shall pay County a penalty fee of Fifty Dollars (\$50.00) per day from the date of County's notice until the violation has been corrected. Permittee shall pay County within ten (10) days of the date of the violation.

6.02 Service Standards. Permittee shall only provide Authorized Aeronautical Services in a first class professional manner, consistent with good business practice and shall at all times observe and comply with the following service standards:

- A. Permittee shall hire and assign a full-time manager or managers, qualified and experienced in the management and control of the services authorized to be performed herein. Manager(s) shall be delegated sufficient authority to ensure proper performance of the terms and conditions of this Permit. Permittee shall also provide at least two (2) twenty-four (24) hour telephone numbers to enable the Department to contact the manager or supervisory personnel whenever necessary. Permittee shall be responsible to inform the Department of any change in name(s) and/or number(s) of the managers and supervisory personnel.

- B. Permittee shall properly control the conduct, demeanor and appearance of its employees. Permittee shall cause its employees to discharge their duties in a professional, courteous and efficient manner, be suitably uniformed and wear appropriate identification. Permittee shall ensure that its employees' uniforms are at all times in good, neat and clean condition.
- C. Permittee's employees shall at all times be under the control and supervision of Permittee, including during slack periods, between job assignments, and during break periods and meals. Permittee shall not permit its employee to loiter in the public areas of the Terminal, including, but not limited to, the baggage claim level and public passenger lounge areas.
- D. Permittee shall not provide Porter Assistance Service within the U.S. Customs facilities located at the Port of Entry Building, or the FIS Facility at the Terminal, without the specific prior written approval of County.
- E. Permittee shall only be permitted to provide Porter Assistance Services in the baggage claim level of the Terminal for flights Permittee is servicing for a particular airline pursuant to Permittee's Service Contract with such airline ("Contracted Flights") upon the request of a passenger of such airline. Permittee shall not permit its employees to loiter or solicit passengers for Porter Assistance Services in the baggage claim level of the Terminal during periods between Contracted Flights. Permittee shall not permit its employees to block or prevent passengers from accessing self-service baggage carts. In the event Permittee or its employees is found to be in violation of the requirements of this paragraph, Permittee shall pay County a penalty fee of Fifty Dollars (\$50.00) per violation within ten (10) days of the date of the violation. County shall provide Permittee with a written notice of each such violation, which shall include the name of the employee, date and time of the violation and any other pertinent information related to the violation.
- F. Permittee shall not permit its employees to solicit or request tips or gratuities, directly or indirectly from Airport passengers.
- G. Permittee shall cause its employees to dispose of found property in accordance with Department approved procedures.
- H. Permittee shall not permit its employees to annoy, harass or disturb any Airport passengers, tenants or users of the Airport.
- I. Permittee shall be responsible, at Permittee's sole cost and expense, for providing appropriate break and meal areas for its employees and contractors.

J. Permittee shall furnish good, prompt and efficient service adequate to meet all the demands for its service at the Airport, and furnish services on a fair, equal and non-discriminatory basis to all users thereof. Permittee shall charge fair, reasonable, and nondiscriminatory prices for its services at the Airport.

6.03. Removal of Employees. County shall have the right to require the removal of any employee of Permittee who fails to comply with the requirements of this Permit. County shall also have the right to revoke the security badge of any employee who fails to comply with the requirements of this Permit.

ARTICLE 7 **INSURANCE**

Permittee agrees to maintain, on a primary basis and at its sole expense, at all times during the Term, the insurance coverages and limits set forth in Exhibit "A" (the "Insurance Requirements"), attached hereto and incorporated herein.

ARTICLE 8 **AIRPORT SECURITY**

8.01 General. Permittee shall observe all security regulations and other requirements of County and any agency of the Federal government, including, but not limited to, the FAA and TSA, applicable to Permittee, as such regulations or requirements have been or may be amended, including without limitation, Title 14, Part 139 of the Code of Federal Regulations and Title 49, Part 1540, et seq., of the Code of Federal Regulations. Permittee agrees to comply with the Airport Security Program and the Air Operations Area (AOA) Vehicle Access Program, and amendments thereto, and to comply with such other rules and regulations as may be prescribed by County, and to take such steps as may be necessary or directed by County to insure that Permittee's employees, invitees and guests observe these requirements. County shall have the right to conduct background checks of Permittee's employees and contractors to the extent required by any federal, state or local law or as required by County. Permittee shall be responsible for the costs of all background checks. County shall have the right to require the removal or replacement of any employee of Permittee at the Airport that County has determined may present a risk to public safety or the security of the Airport. If as a result of the acts or omissions of Permittee or its employees, invitees or guests, County incurs any fines and/or penalties imposed by the FAA or TSA; any expense in enforcing the regulations of the FAA or TSA or the rules or regulations of County; or any expense in enforcing the Airport Security Program, then Permittee agrees to pay to County all such costs and expenses, including all costs of administrative proceeding, court costs, and attorneys fees and all costs incurred by County in enforcing this provision. Permittee further agrees to rectify any security deficiency or other deficiency as may be determined by County, the FAA or TSA. In the event Permittee fails to remedy any such deficiency, County may do so at the cost and expense of Permittee. Permittee acknowledges and agrees that County may take whatever action is necessary to rectify any security deficiency or any other deficiency identified by County, the FAA or TSA.

8.02 Badges. Permittee shall be responsible for requesting County to issue security badges to all employees who require access to restricted areas on the Airport as part of the employees regularly assigned duties. Permittee shall be responsible for reporting all lost or stolen security badges and the immediate return of security badges of all personnel transferred from the Airport or terminated from the employ of Permittee or upon the termination of this Permit. Permittee shall pay, or cause to be paid, to County charges that may be established from time to time, for issuance of security badges, fingerprinting fees, and lost or stolen security badges.

ARTICLE 9
RELATIONSHIP OF THE PARTIES

Permittee is and shall be deemed to be an independent contractor and operator, responsible to all parties for its respective acts or omissions, and County shall in no way be responsible therefor.

ARTICLE 10
INDEMNIFICATION

Permittee agrees to protect, defend, reimburse, indemnify and hold County, its agents, employees and each of them, free and harmless at all times from and against any and all claims, liability, expenses, losses, costs, fines and damages (including attorney fees at trial and appellate levels) and causes of action of every kind and character against or from County by reason of any damage to property or the environment, or bodily injury (including death) incurred or sustained by any party hereto, or of any party acquiring any interest hereunder, any agent or employee of any party hereto or of any party acquiring an interest hereunder, and any third or other party whomsoever, or any governmental agency, arising out of or incident to or in connection with Permittee's performance under this Permit, Permittee's acts, omissions or operations hereunder, or the performance, non-performance or purported performance of Permittee or any breach of the terms of this Permit; provided, however, Permittee shall not be responsible to County for damages resulting out of bodily injury or damages to property which are judicially determined to be solely attributable to the sole negligence of County, its respective agents, servants, employees and officers. Permittee further agrees to hold harmless and indemnify County for any fines, citations, court judgments, insurance claims, restoration costs or other liability resulting from or in any way arising out of or due to Permittee's activities or operations on the Airport, whether or not Permittee was negligent or even knowledgeable of any events precipitating a claim or judgment arising as a result of any situation involving said activities. Said indemnification shall be extended to include all deliverers, suppliers, furnishers of material, or anyone acting for or on behalf of, or at the request of Permittee. Permittee recognizes the broad nature of this indemnification and hold harmless clause, and voluntarily makes this covenant and expressly acknowledges the receipt of ten dollars (\$10.00) and such other good and valuable consideration provided by County in support of this indemnification in accordance with laws of the State of Florida. This clause shall survive the termination of this Permit.

ARTICLE 11
TERMINATION OF PERMIT, PERMIT VIOLATIONS AND REMEDIES

11.01 Termination. This Permit shall terminate as provided for in Article 3.

11.02 Permit Violations. The occurrence of any one or more of the following events shall constitute a violation of this Permit by Permittee:

- A. Permittee's failure to make payment of any fees or charges required to be made by Permittee under this Permit, as and when due.
- B. The failure by Permittee to observe or perform any of the covenants, conditions or provisions of this Permit to be observed or performed by Permittee.
- C. The discovery by County that any information given by Permittee to County relating to this Permit was materially false.
- D. A default by Permittee of any other agreement, permit or lease between County and Permittee, which default has not been cured within the applicable cure period provided in such agreement, permit or lease.

11.03 Remedies In addition to any other remedy available under the law or this Permit, County may terminate this Permit upon written notice to Permittee. Upon such termination, Permittee shall immediately cease its operations on the Airport. Such termination shall be without prejudice to any of County's remedies for arrearages, payments due herein, or any other damages or remedies whatsoever.

11.04 County's Right to Terminate. This Permit is issued upon the terms and conditions required by County for all Permittees on the Airport that engage in the activities permitted herein. Upon ten (10) days' prior written notice, County may, at any time, terminate this Permit and at County's option issue a new Permit to Permittee upon such modified terms and conditions as County shall uniformly apply to all other similarly situated Permittees.

ARTICLE 12
ASSIGNMENT

Permittee shall not in any manner assign, transfer or otherwise convey an interest in this Permit. Any such attempt shall be null and void.

ARTICLE 13
SIGNS

No signs, posters or similar devices shall be erected, displayed or maintained by Permittee in the view of the general public in, on or about the Airport without the prior written approval of County. Any such signs not approved shall be immediately removed at the sole cost and expense of Permittee, upon written notification thereof by County.

ARTICLE 14
LAWS, REGULATIONS, PERMITS AND SAFETY REGULATIONS

14.01 Compliance with Laws. Permittee shall be and remain in full and complete compliance with all applicable Federal, State and local laws, statutes, regulations, rules, rulings, orders, ordinances and directives of any kind or nature without limitation, as now or hereafter amended, including, but not limited to, FAA Advisory Circulars and Airport Rules and Regulations. Permittee shall ensure that its agents, contractors, employees, invitees and guests entering the Airport with or without Permittee's consent or knowledge comply with all applicable laws on the Airport.

14.02 Permits and Licenses. Permittee shall, at its sole cost and expense, be strictly liable and responsible for obtaining, paying for, fully complying with, and maintaining current any and all permits, licenses or other governmental authorizations, however designated, as may be required at any time throughout the Term of this Permit by any Federal, State or local governmental entity or any court of law having jurisdiction over Permittee or Permittee's operations and activities, for any activity or operation conducted by Permittee on the Airport. Upon written request by Department, Permittee shall provide to Department certified copies of any and all permits and licenses that Department may request.

14.03 Safety Regulations. Permittee shall conduct its activities and operations under this Permit in a safe manner and in compliance with all safety regulations of the Department and with safety standards imposed by applicable Federal, State and local laws and regulations. Permittee shall also require the observance thereof by all employees, agents and invitees. Permittee shall procure and maintain such fire prevention and extinguishing devices as required by County and by law and shall at all times be familiar and comply with the fire regulations and orders of County and the fire control agency with jurisdiction over the Airport. Neither Permittee, nor employee, agent, or any person working for or on behalf of Permittee, shall require any personnel engaged in the performance of Permittee's operations to work in surroundings or under working conditions that are unsanitary, hazardous, or dangerous to individual safety or health, as determined by standards adopted pursuant to the Occupational Safety and Health Act of 1970, as same may be amended from time to time, as well as all State and local laws, regulations, and orders relative to occupational safety and health.

14.04 Compliance with Environmental Laws. Permittee shall, at its sole cost and expense, comply with all applicable Environmental Laws. For purposes of this Permit, "Environmental Laws" means all applicable Federal, State and local laws, rules, orders and regulations protecting human health, the environment and/or natural resources, as such laws, rules, orders and regulations are now or hereafter amended, including, without limitation, the Federal Clean Water Act, Federal Safe Drinking Water Act, Federal Clean Air Act, Federal Resource Conservation and Recovery Act and Comprehensive Environmental Response, Compensation and Liability Act of 1980. Permittee shall indemnify, defend and hold County harmless from any and all penalties, fines, costs, expenses, suits, claims or damages resulting from Permittee's failure to perform its obligations specified in this Section 14.04. The foregoing indemnification agreement shall survive the expiration or earlier termination of this Permit.

ARTICLE 15
DISCLAIMER OF LIABILITY

COUNTY HEREBY DISCLAIMS, AND PERMITTEE HEREBY RELEASES COUNTY, FROM ANY AND ALL LIABILITY, WHETHER IN CONTRACT OR TORT (INCLUDING STRICT LIABILITY, NEGLIGENCE AND NUISANCE), FOR ANY LOSS, DAMAGE, OR INJURY OF ANY NATURE WHATSOEVER SUSTAINED BY PERMITTEE, ITS EMPLOYEES, AGENTS, OR INVITEES DURING THE TERM OF THIS PERMIT INCLUDING, BUT NOT LIMITED TO, LOSS, DAMAGE, OR INJURY TO THE IMPROVEMENTS OR PERSONAL PROPERTY OF PERMITTEE OR PERMITTEE'S BUSINESS INVITEES THAT MIGHT BE LOCATED OR STORED ON THE AIRPORT, UNLESS SUCH LOSS, DAMAGE, OR INJURY IS JUDICIALLY DETERMINED TO HAVE BEEN CAUSED BY COUNTY'S SOLE NEGLIGENCE OR BY COUNTY'S BREACH OF ITS OBLIGATIONS UNDER THIS PERMIT. THE PARTIES EXPRESSLY AGREE THAT UNDER NO CIRCUMSTANCES SHALL COUNTY BE LIABLE FOR INDIRECT, CONSEQUENTIAL, SPECIAL, OR EXEMPLARY DAMAGES WHETHER IN CONTRACT OR TORT (INCLUDING STRICT LIABILITY, NEGLIGENCE, AND NUISANCE), SUCH AS, BUT NOT LIMITED TO, LOSS OF REVENUE OR ANTICIPATED PROFITS OR ANY OTHER DAMAGE RELATED TO THE ASSIGNMENT OF THE AIRPORT TO PERMITTEE PURSUANT TO THIS PERMIT. PERMITTEE ACKNOWLEDGES AND AGREES THAT COUNTY SHALL HAVE NO LIABILITY WHATSOEVER AND PERMITTEE COVENANTS AND AGREES TO HOLD HARMLESS COUNTY FROM ANY AND ALL LIABILITY RELATING TO ANY INFORMATION PROVIDED BY COUNTY RELATING TO THIS PERMIT. FURTHERMORE, PERMITTEE ACKNOWLEDGES AND AGREES THAT ITS USE OF ANY SUCH INFORMATION, WHETHER PREPARED OR PROVIDED BY COUNTY OR OTHERWISE, IN DETERMINING WHETHER TO ENTER INTO THIS PERMIT, WAS AT ITS SOLE RISK.

ARTICLE 16
GOVERNMENTAL RESTRICTIONS

16.01 Federal Right to Reclaim. In the event a United States governmental agency shall demand and take over either the entire facilities of the Airport or the portion wherein Permittee is authorized to operate pursuant to this Permit, for public purposes, then this Permit shall thereupon terminate and County shall be released and fully discharged from any and all liability hereunder.

16.02 Federal Review. This Permit is subject to any applicable review by the Federal Aviation Administration to determine satisfactory compliance with federal law. This Permit shall be in full force and effect and binding upon both parties pending review and approval by said Federal Aviation Administration.

16.03 County Tax Assessment Right. None of the terms, covenants and conditions of this Permit shall in any way be construed as a release or waiver on the part of County, as a political subdivision of the State of Florida, or any of the public officials of Palm Beach County,

of the right to assess, levy and collect any license, personal, intangible, occupation or any other tax which shall be lawfully imposed on the business or property of Permittee.

16.04 Right of Flight. County reserves unto itself, its successors and assigns, for the use and benefit of the public, a right of flight for the passage of aircraft in the airspace above the surface of the real property previously described, together with the right to cause in said airspace such noise as may be inherent in the operation of aircraft now known or hereafter used, for navigation of or flight in the said airspace and for landing on, taking off from or operating on the Airport.

16.05 Operation of Airport. Permittee expressly agrees for itself, its successors and assigns, to prevent any use of Airport property which would interfere with or adversely affect the operation or maintenance of the Airport, or otherwise constitute an Airport hazard.

ARTICLE 17 **NON-DISCRIMINATION**

17.01 Non-Discrimination. Permittee for itself, its successors in interest and assigns, as a part of the consideration hereof, does hereby covenant and agree: (1) that in the furnishing of services permitted herein, no person on the grounds of race, color, age, religion, sex, gender identity or expression, familial status, or natural origin shall be excluded from participation in, denied the benefits of, or otherwise be subjected to discrimination; and (2) that Permittee shall operate in compliance with all other requirements imposed by or pursuant to Title 49, Code of Federal Regulations, Department of Transportation, Subtitle A, Office of the Secretary, Part 21, Non-discrimination in Federally-Assisted Programs of the Department of Transportation-Effectuation of Title VI of the Civil Rights Act of 1964, and as said regulations may be amended. In the event of the breach of any of the foregoing non-discrimination covenants, County shall have the right to terminate this Permit and all privileges and rights granted to Permittee hereunder. This cancellation provision shall not be effective until the procedures of Title 49, Code of Federal Regulations, Part 21, are followed and completed including exercise or expiration of appeal rights.

17.02 Disadvantaged Business Enterprise/Affirmative Action. Permittee acknowledges that the provisions of 49 CFR Part 26, Disadvantaged Business Enterprise (DBE), and 14 CFR Part 152, Affirmative Action Employment Programs, may become applicable to the activities of Permittee under the terms of this Permit, unless exempted by said regulations, and Permittee hereby agrees to comply with all requirements of the Department, the Federal Aviation Administration and the U.S. Department of Transportation, in reference thereto. These requirements may include, but not be limited to, the compliance with DBE and/or Employment Affirmative Action participation goals, the keeping of certain records of good faith compliance efforts, which would be subject to review by the various agencies, and the submission of various reports, and including, if directed by the Department, the contracting of specified percentages of goods and services contracts to Disadvantaged Business Enterprises. Failure to comply with these requirements shall be grounds for default and cancellation of this Permit. Any cancellations pursuant to this Section 17.02 shall not be effective until the procedures specified in said Federal regulations or established by County are completed, including exercise or expiration of appeal rights.

ARTICLE 18
MISCELLANEOUS

18.01 Non-Exclusive Agreement. Permittee expressly understands and agrees that the rights and privileges granted under this Permit are non-exclusive, and County herein reserves the right to grant similar rights and privileges to others at the Airport.

18.02 County Not Liable. County shall not be responsible or liable to Permittee for any claims for compensation or any losses, damages or injury sustained by Permittee resulting from (1) cessation for any reason of air carrier operations at the Terminal, or (2) diversion of passenger traffic to any other facility. County shall not be responsible nor liable to Permittee for any claims for compensation or any losses, damages, or injury sustained by Permittee resulting from failure of any water supply, electrical current, sewerage or drainage facility, or caused by natural physical conditions on the Airport, whether on the surface or underground, including stability, moving, shifting, settlement of ground, or displacement of materials by fire, water, windstorm, tornado, hurricane, act of God or state of war, civilian commotion or riot, or any cause beyond the control of County. All personal property placed on or moved onto the Airport shall be at the sole risk of Permittee or owner thereof and Permittee expressly acknowledges and agrees that County shall not be liable for any damage to or loss of said personal property.

18.03 Authorized Uses Only. Notwithstanding anything to the contrary herein, Permittee will not use or permit the use of the Airport for any illegal or improper purpose or for any purpose which would invalidate any policies of insurance, now existing or hereafter written on Airport for County or Permittee.

18.04 Waivers. The failure of either party to insist on strict performance of any of the agreements, terms, covenants and conditions hereof shall not be deemed a waiver of any rights or remedies that such party may have for any subsequent breach, default, or non-performance, and such party's right to insist on strict performance of this Permit shall not be affected by any previous waiver or course of dealing.

18.05 Subordination

A. Subordination to Bond Resolution. This Permit and all rights granted to Permittee hereunder are expressly subordinated and subject to the lien and provisions of the pledges, transfer, hypothecation or assignment made by County in the Bond Resolution, and County and Permittee agree that to the extent permitted by authorizing legislation, the holders of the bonds or their designated representatives may exercise any and all rights of County hereunder to the extent such possession, enjoyment and exercise are necessary to ensure compliance by Permittee and County with the terms and provisions of this Permit and the Bond Resolution.

B. Subordination to Federal/State Agreements. This Permit shall be subject and subordinate to all the terms and conditions of any instruments and documents under which County acquired the land or improvements thereon and shall be given only such effect as will not conflict with nor be inconsistent with such terms and conditions. Permittee understands and agrees that this Permit shall be subordinate to the provisions of any existing or future agreement between County and the United States of America, the State of Florida, or any of their agencies, relative to the operation or maintenance of the Airport, the execution of which has been or may

be required as a condition precedent to the expenditure of Federal Funds for the development of the Airport.

18.06 Consent, Approval and Governmental Authority. Nothing in this Permit shall be construed to waive or limit County's governmental authority as a political subdivision of the State of Florida to regulate Permittee or its operations.

18.07 Rights Reserved to County. All rights not specifically granted Permittee by this Permit are reserved to County.

18.08 Invalidity of Clauses. The invalidity of any portion, article, paragraph, provision, clause or any portion thereof of this Permit shall have no affect upon the validity of any other part or portion hereof.

18.09 Venue. To the extent allowed by law the venue for any action arising from this Permit shall be in Palm Beach County, Florida.

18.10 Governing Law. This Permit shall be governed by and in accordance with the laws of the State of Florida.

18.11 Notice. All notices and elections (collectively, "notices") to be given or delivered by or to any party hereunder, shall be in writing and shall be (as elected by the party giving such notice) hand delivered by messenger, courier service or overnight mail, telecopied or faxed (provided in each case a receipt is obtained), or alternatively shall be sent by United States Certified Mail, with Return Receipt Requested. The effective date of any notice shall be the date of delivery of the notice if by personal delivery, courier services or overnight mail, or on the date of transmission with confirmed answer back if by telecopier or fax if transmitted before 5PM on a business day and on the next business day if transmitted after 5PM or on a non-business day, or if mailed, upon the date which the return receipt is signed or delivery is refused or the notice designated by the postal authorities as non-deliverable, as the case may be. The parties hereby designated the following addresses as the addresses to which notices may be delivered, and delivery to such addresses shall constitute binding notice given to such party:

County:

Attn: Deputy Director, Airports Business Affairs
Palm Beach County Department of Airports
846 Palm Beach International Airport
West Palm Beach, Florida 33406-1470
Fax: 561-471-7427

With a copy to:
Attn: Airport Attorney
Palm Beach County Attorney's Office
301 North Olive Ave, Suite 601
West Palm Beach, FL 33401
Fax: 561-355-4398

Permittee:

Palm Beach Delivery d/b/a Yankee Express
Attn: Eileen Lawler
1000 PBIA Box 129
West Palm Beach, Florida 33406
Fax: _____

Any party may from time to time change the address to which notice under this Permit shall be given such party, upon three (3) days prior written notice to the other party.

18.12 Paragraph Headings. The headings of the various articles and sections of this Permit are for convenience and ease of reference only, and shall not be construed to define, limit, augment or describe the scope, context or intent of this Permit or any part or parts of this Permit.

18.13 Binding Effect. The terms, conditions and covenants of this Permit shall inure to the benefit of and be binding upon the parties hereto and their successors and assigns, if any. This provision shall not constitute a waiver of any prohibitions against or limitations regarding assignment or transfer.

18.14 Performance. The parties expressly agree that time is of the essence in this Permit and the failure by Permittee to complete performance within the time specified, or within a reasonable time if no time is specified herein, shall, at the option of County without liability, in addition to any other of County's rights or remedies, relieve County of any obligation to accept such performance.

18.15 Public Entity Crimes. As provided in Section 287.132-133, Florida Statutes, by entering into this Permit or performing any work in furtherance hereof, Permittee certifies that it, its affiliates, suppliers, subcontractors and consultants who will perform hereunder, have not been placed on the convicted vendor list maintained by the State of Florida Department of Management Services within the thirty-six (36) months immediately preceding the effective date hereof. This notice is required by Section 287.133(3)(a), Florida Statutes.

18.16 Consent or Action. In the event this Permit is silent as to the standard for any consent, approval, determination, or similar discretionary action, the standard shall be at the sole, absolute and unfettered discretion of County or Department, rather than any implied standard of good faith, fairness or reasonableness. Wherever this Permit requires County or Department's consent or approval or permits County or Department to act, such consent, approval or action may be given or performed by the Airport Director. If Permittee requests County or Department's consent or approval pursuant to any provision of this Permit and County or Department fails or refuses to give such consent, Permittee shall not be entitled to any damages as a result of such failure or refusal, whether or not unreasonable.

18.17 Remedies Cumulative. The rights and remedies of parties hereto with respect to any of the terms and conditions of this Permit shall be cumulative and not exclusive and shall be in addition to all other rights and remedies of the parties.

18.18 Entirety of Agreement. The parties agree that this Permit sets forth the entire agreement between the parties, and there are no promises or understandings other than those stated herein. None of the provisions, terms and conditions contained in this Permit may be added to, modified, superseded or otherwise altered except by written instrument executed by the parties hereto.

18.19 Survival. Notwithstanding any early termination of this Permit, Permittee shall remain obligated hereunder to perform any duty, covenant or obligation imposed upon Permittee hereunder arising prior to the date of such termination.

18.20 Termination of Prior Agreement. Upon the Commencement Date of this Permit, that certain General Aeronautical Services Agreement between Permittee and County, dated September 4, 1998 (R-98-1552D) ("Agreement"), shall be terminated in its entirety; provided, however, that any claim, cause of action, or other obligation to Permittee or to County then accrued, shall survive said termination. Notwithstanding the provisions of Section 5.01(A) of this Permit, Permittee shall not be required to pay an initial application fee for this Permit. Notwithstanding any provision of the Agreement to the contrary, the parties acknowledge and agree that Permittee shall be authorized to comply with the audit provisions set forth in Section 5.07 of this Permit in lieu of the audit provisions set forth in the Agreement.

18.21 Inspector General. County has established the Office of the Inspector General in Ordinance 2009-049, as may be amended, which is authorized and empowered to review past, present and proposed County contracts, transactions, accounts and records. The Inspector General has the power to subpoena witnesses, administer oaths and require the production of records, and audit, investigate, monitor, and inspect the activities of Palm Beach Delivery, Inc. d/b/a Yankee Express and its officers, agents, employees and lobbyists in order to ensure compliance with contract requirements and detect corruption and fraud. Failure to cooperate with the Inspector General or interference or impeding any investigation shall be in violation of Ordinance 2009-049, and punished pursuant to Section 125.69, Florida Statutes, in the same manner as a second degree misdemeanor.

(REMAINDER OF PAGE INTENTIONALLY LEFT BLANK)

IN WITNESS WHEREOF, County has caused this Permit to be signed by the Director of the Department of Airports pursuant to the authority granted by the Board, and Permittee has caused these presents to be signed in its corporate name by its duly authorized officer, and the seal of said Permittee to be affixed hereto, the day and year first written above.

WITNESSES:

Connie Shoffner
Witness Signature

Connie Shoffner
(typed or printed)

Jeff S Bolton
Witness Signature

Jeffrey S. Bolton
(typed or printed)

PALM BEACH COUNTY, a political subdivision of the State of Florida

By: [Signature]
Director, Department of Airports

APPROVED AS TO FORM AND LEGAL SUFFICIENCY

By: Anne Welford
County Attorney

ATTEST:

By: [Signature]
Secretary

(Corporate Seal)

PERMITTEE:

Palm Beach Delivery, Inc.
d/b/a Yankee Express

By: [Signature]
Anderson Kurtz
Typed Name of Corporate Officer

Title: President

Signed, sealed and delivered in the presence of two witnesses for Permittee:

[Signature]
Witness Signature

L. Scott Sims
(typed or printed name)

[Signature]
Witness Signature

Cheri S. Sims
(typed or printed name)

EXHIBIT "A"
INSURANCE REQUIREMENTS

A. Commercial General Liability. Permittee shall maintain Commercial General Liability Insurance at a limit of liability of not less than One Million Dollars (\$1,000,000) each occurrence. Coverage shall not contain any endorsement(s) excluding or limiting Premises/Operations, Damage to Rented Property, Personal Injury, Product/Completed Operations, Contractual Liability, Severability of Interests or Cross Liability. Coverage shall be provided on a primary basis.

B. Business Automobile Liability. Permittee shall maintain Business Automobile Liability Insurance at a limit of liability of not less than One Million Dollars (\$1,000,000) each occurrence. Coverage shall include liability for Owned, Non-Owned & Hired automobiles. In the event the Permittee does not own automobiles, Permittee shall maintain coverage for Hired & Non-Owned Auto Liability, which may be satisfied by way of endorsement to the Commercial General Liability policy or separate Business Auto Liability policy. Coverage shall be provided on a primary basis.

C. Worker's Compensation Insurance & Employers Liability. Permittee shall maintain Worker's Compensation Insurance & Employers Liability in accordance with Florida Statute Chapter 440. Coverage shall be provided on a primary basis.

D. Additional Insured. Permittee shall provide the Department with a certificate, or certificates, of insurance, evidencing limits, coverages and endorsements as required herein. Permittee shall endorse County as an Additional Insured with a "**CG026 Additional Insured - Designated Person or Organization**" endorsement to the Commercial General Liability policy. The additional insured endorsement shall read: "**Palm Beach County Board of County Commissioners, a Political Subdivision of the State of Florida, its Officers, Employees and Agents, c/o Palm Beach County Department of Airports, 846 Palm Beach International Airport, West Palm Beach, FL 33406.**" Coverage shall be provided on a primary basis. All certificates of insurance shall include a minimum thirty (30) day endeavor to notify due to cancellation or non-renewal of coverage. In the event coverage is cancelled or is not renewed during the Term, Permittee shall provide County a new certificate of insurance or certificates of insurance evidencing replacement coverage no later than thirty (30) days prior to the expiration or cancellation of the coverage. The certificate holder's name and address shall read "**Palm Beach County Board of County Commissioners c/o Palm Beach County Department of Airports, 846 Palm Beach International Airport, West Palm Beach, Florida 33406.**"

E. Deductibles, Coinsurance & Self-Insured Retention. Permittee shall be fully and solely responsible for any deductible, coinsurance penalty, or self-insured retention; including any losses, damages, or expenses not covered due to an exhaustion of limits or failure to comply with the policy.

F. Waiver of Subrogation. By entering into this Permit, Permittee agrees to a Waiver of Subrogation for each policy required herein. When required by the insurer, or should a policy condition not permit Permittee to enter into any pre-loss agreement to waive subrogation without an endorsement, then Permittee agrees to notify the insurer.

G. Right to Review or Adjust Insurance. The County's Risk Management Department may review, modify, reject or accept any required policies of insurance, including, but not limited to, limits, coverages or endorsements, required by herein from time to time throughout the Term. County may also reject any insurer or self-insurance plan providing coverage because of poor financial condition or failure to operate legally. In such event, County shall provide Permittee a written notice of rejection, and Permittee shall comply within thirty (30) days of receipt of the notice.

H. No Representation of Coverage Adequacy. Permittee acknowledges the limits, coverages and endorsements required herein are intended to minimize liability for County. Permittee agrees that it will not rely upon the requirements herein when assessing the extent or determining appropriate types or limits of insurance coverage to protect Permittee against any loss exposures, whether as a result of this Permit or otherwise.

**SECOND AMENDMENT TO AIRLINE-AIRPORT USE AND LEASE AGREEMENT
BETWEEN PALM BEACH COUNTY AND JETBLUE AIRWAYS**

THIS SECOND AMENDMENT TO THE AIRLINE-AIRPORT USE AND LEASE AGREEMENT (this "Amendment") is made and entered into JAN 07 2010, by and between Palm Beach County, a political subdivision of the State of Florida ("COUNTY"), and JetBlue Airways Corporation, A Delaware corporation having its offices and principal place of business at 118-29 Queens Blvd., Forest Hills, New York, 11375 ("AIRLINE").

WITNESSETH:

WHEREAS, COUNTY, by and through its Department of Airports (the "Department"), owns and operates the Palm Beach International Airport, located in Palm Beach County, Florida; and

WHEREAS, pursuant to the Airline-Airport Use and Lease Agreement between COUNTY and AIRLINE dated December 29, 2006 (R-2007-0272), as amended (the "Agreement"), AIRLINE leases various Airport Terminal facilities and equipment in connection with its operations as a commercial air carrier; and

WHEREAS, the Director of the Department has been delegated the authority to execute certain amendments to the Agreement pursuant to County Resolution No. 2006-1906; and

WHEREAS, the parties desire to amend the Agreement as provided for herein.

NOW, THEREFORE, in consideration of the premises and of the mutual covenants herein contained, and for other good and valuable consideration, the receipt of which the parties hereby expressly acknowledge, the parties hereto covenant and agree to the following terms and conditions:

1. The foregoing recitals are true and correct and are hereby incorporated herein by reference and made a part hereof. Terms not defined herein shall have the meaning ascribed to them in the Agreement.

2. The parties agree that effective December 1, 2010, Exhibit "B" and "D" to the Agreement shall be replaced with the Exhibit "B" and "D" to this Amendment.

3. Exhibits attached hereto and referenced herein shall be deemed to be incorporated in this Amendment by such reference.

4. Except as specifically modified herein, all of the terms and conditions of the Agreement shall remain unmodified and in full force and effect and are hereby ratified and confirmed by the parties hereto.

5. Palm Beach County has established the Office of the Inspector General, Ordinance R2009-049, as may be amended. The Inspector General's authority includes but is not limited to the power to review past, present and proposed County contracts, transactions, accounts and records, to require the production of records, and audit, investigate, monitor, and inspect the activities of the contractor, its officers, agents, employees, and lobbyists in order to ensure compliance with contract specifications and detect corruption and fraud. All contractors and parties doing business with the County and receiving County funds shall fully cooperate with the Inspector General including receiving access to records relating to Bid or any resulting contract.

6. This Amendment shall become effective when signed by both the parties hereto.

IN WITNESS WHEREOF, the parties hereto have duly executed this Amendment as of the day and year first above written

Signed, sealed and delivered in the presence of two (2) witnesses for

COUNTY:

Connie Shoffner

Signature

Connie Shoffner

Print Name

Jeffrey S. Bolton

Signature

Jeffrey S. Bolton

Print Name

PALM BEACH COUNTY, a political subdivision of the State of Florida

BY: [Signature]
Director, Department of Airports

APPROVED AS TO FORM & LEGAL SUFFICIENCY:

Anne Delgado
County Attorney

Signed, sealed and delivered in the presence of two (2) witnesses for

AIRLINE:

Neal Green

Signature

NEAL GREEN

Print Name

[Signature]

Signature

Mike Stone

Print Name

AIRLINE: JetBlue Airways
By: [Signature]

Richard Smyth
Typed or printed name of Corporate Officer

Title: Vice President Corporate Real Estate

(Seal)

EXHIBIT "B"

EXHIBIT "B" to Airline Operating and Lease Agreement
JetBlue Airways

EXCLUSIVE & PREFERENTIAL USE PREMISES (Terminal Areas)
First Level Plan – Palm Beach International Airport

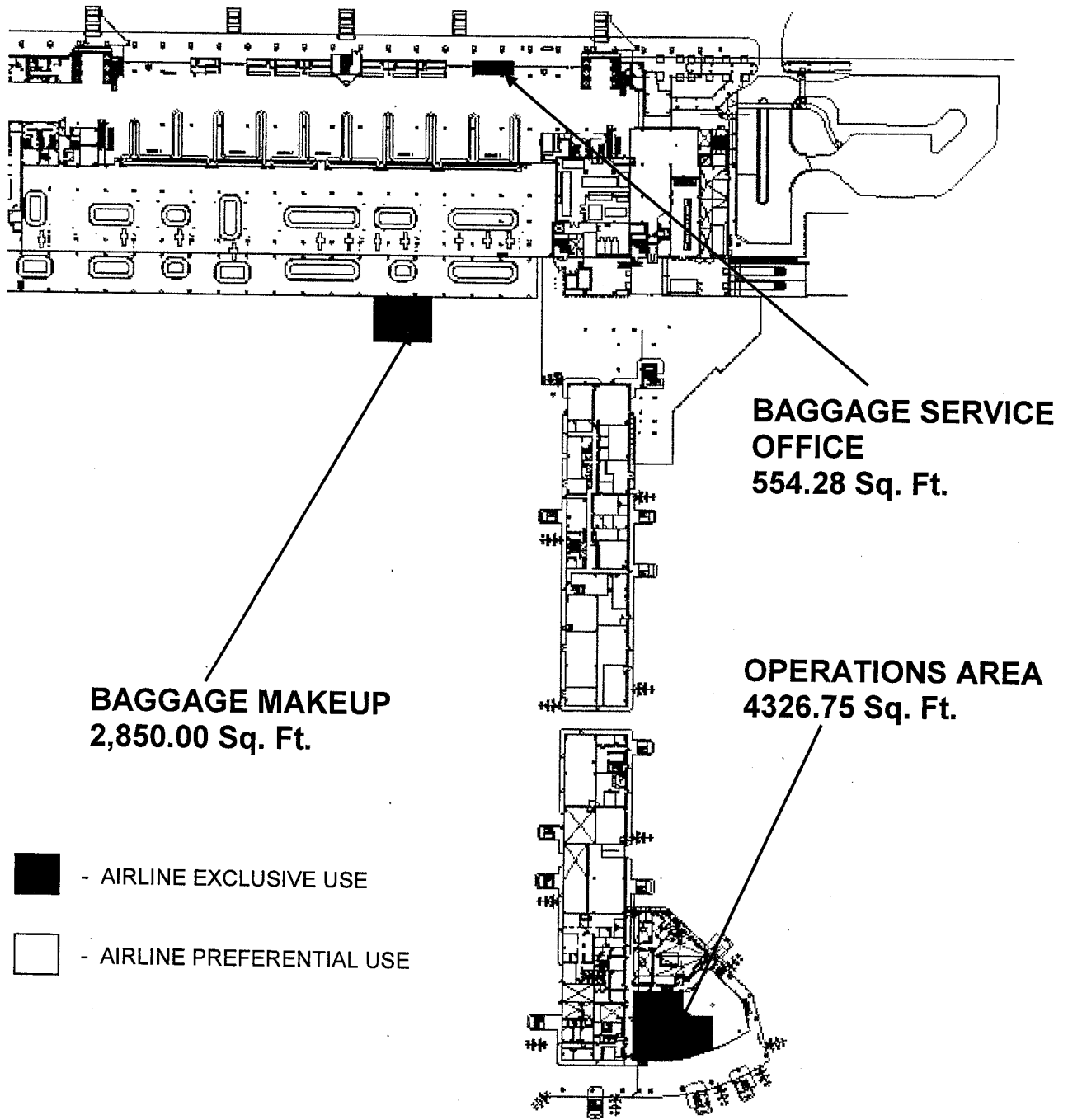
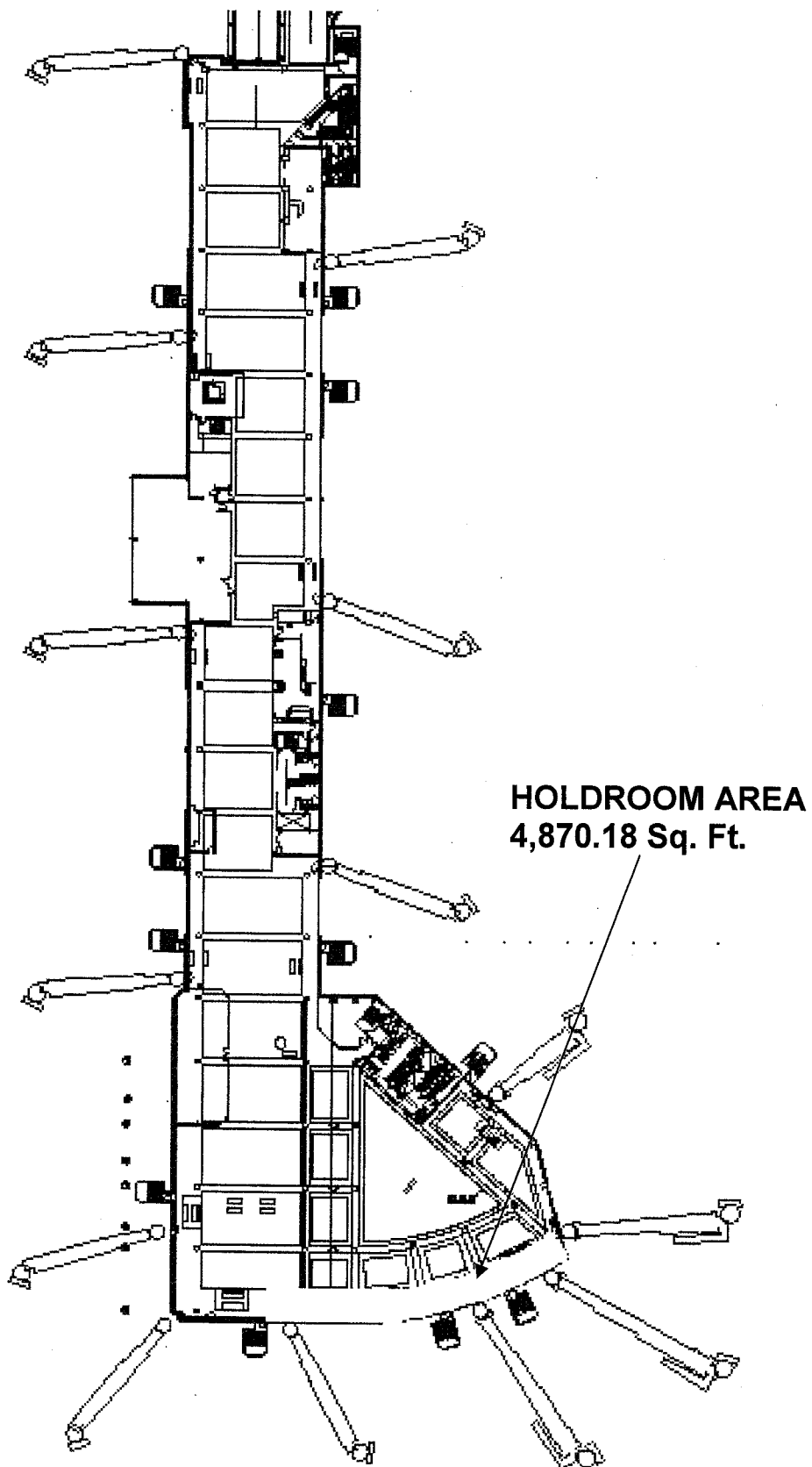



EXHIBIT "B" to Airline Operating and Lease Agreement
JetBlue Airways

EXCLUSIVE & PREFERENTIAL USE PREMISES (Terminal Areas)
Second Level Plan – Palm Beach International Airport



-  - AIRLINE EXCLUSIVE USE
-  - AIRLINE PREFERENTIAL USE

**NO EXCLUSIVE USE OR
PREFERENTIAL USE PREMISES**

EXHIBIT "B" to Airline Operating and Lease Agreement
JetBlue Airways

EXCLUSIVE & PREFERENTIAL USE PREMISES (Terminal Areas)
Third Level Plan – Palm Beach International Airport

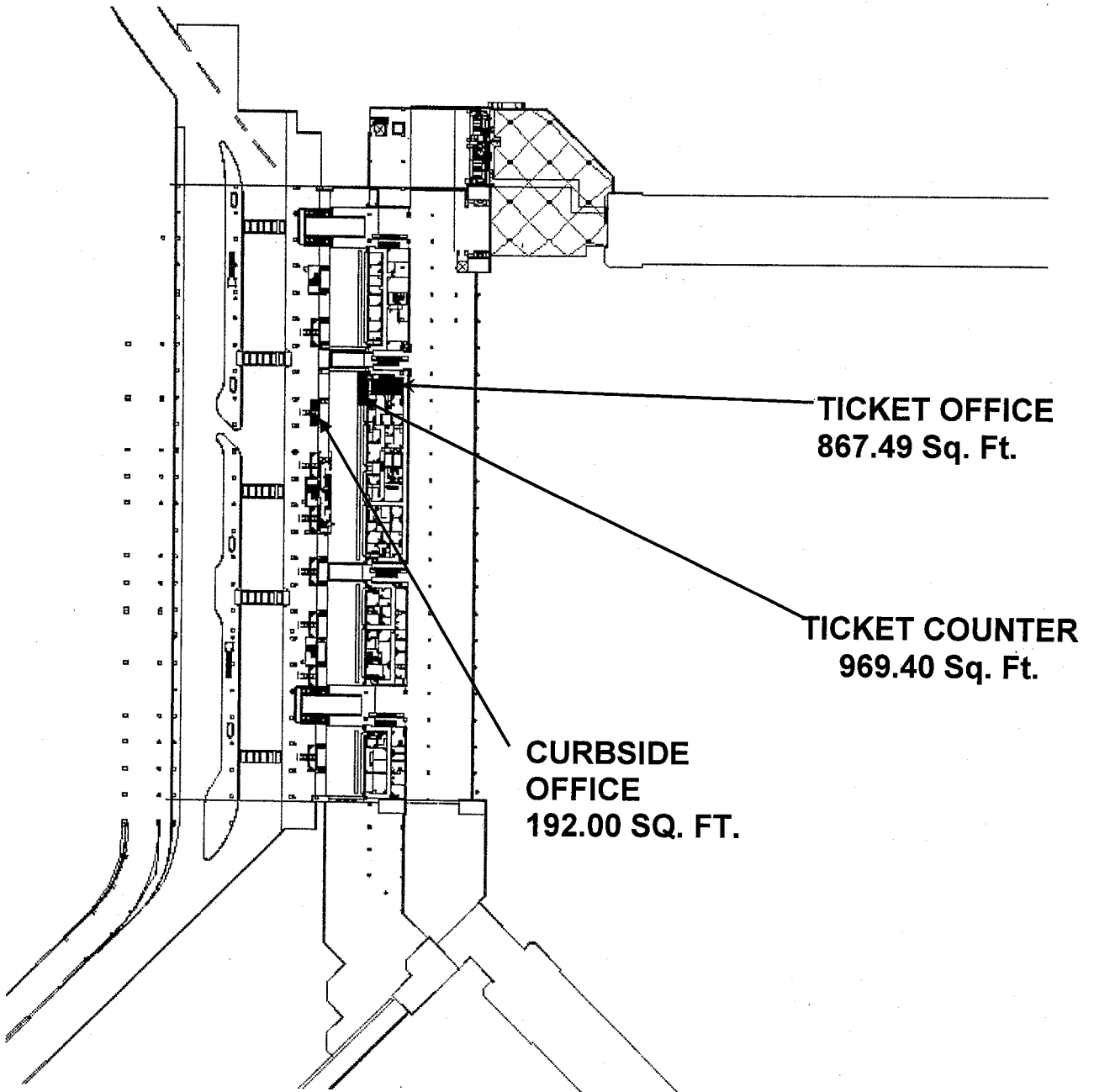



-  - AIRLINE EXCLUSIVE USE
-  - AIRLINE PREFERENTIAL USE

EXHIBIT "D"

EXHIBIT "D" to Airline-Airport Use and Lease Agreement
JETBLUE AIRWAYS

PREFERENTIAL USE PREMISES (Aircraft Parking Apron)
Concourse C – Palm Beach International Airport

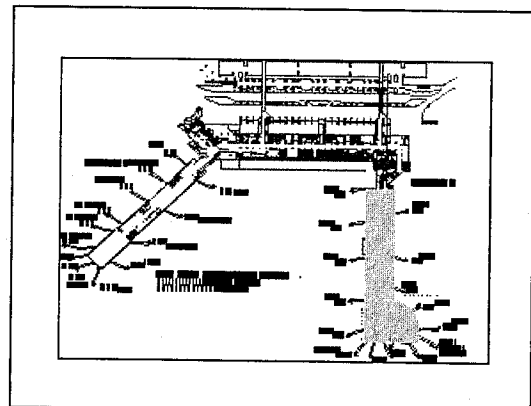
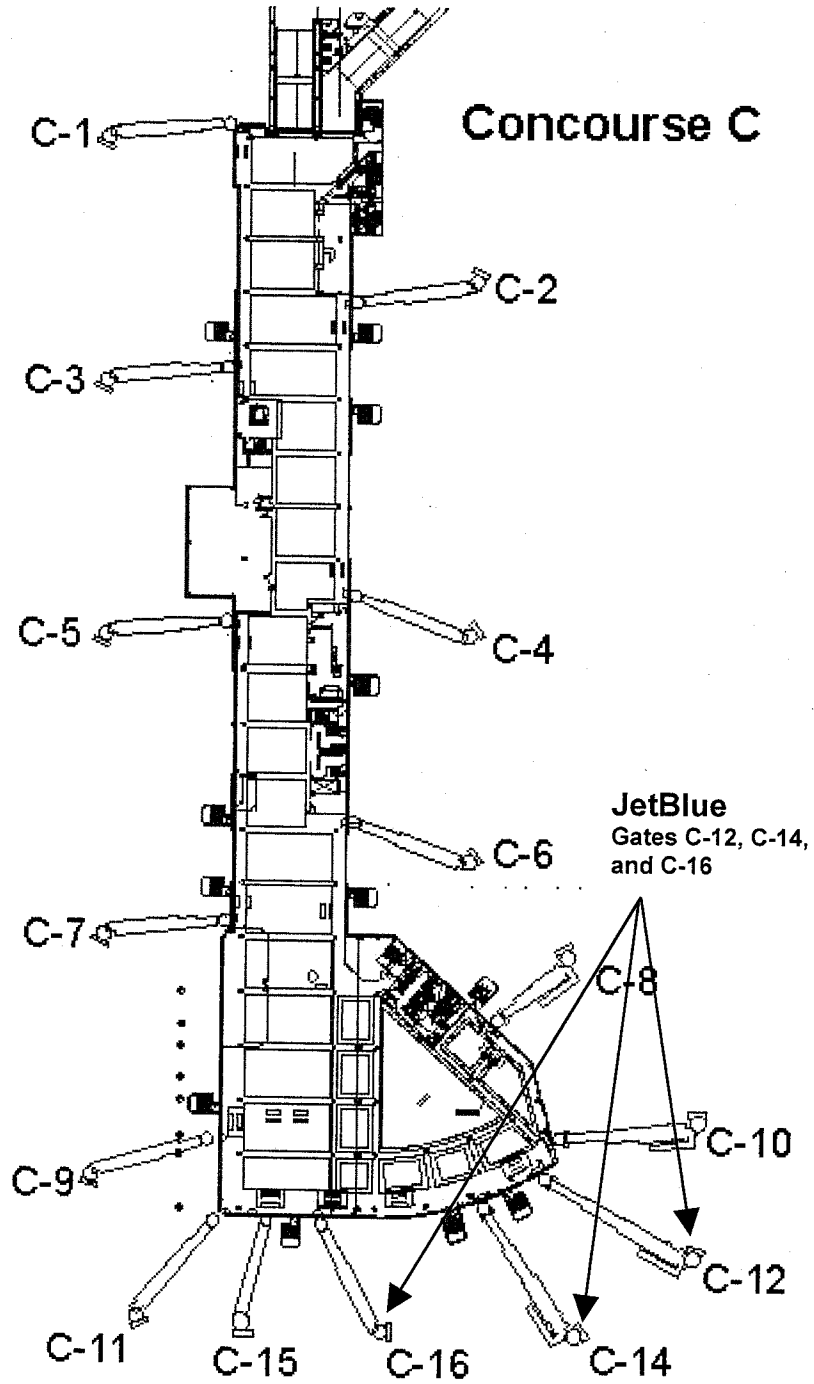

Effective December 1, 2010