

PALM BEACH COUNTY
BOARD OF COUNTY COMMISSIONERS
AGENDA ITEM SUMMARY

Meeting Date: March 6, 2012 {X} Consent { } Regular
{ } Public Hearing { } Workshop

Department:
Submitted By: Engineering and Public Works
Submitted For: Engineering Services Division

I. EXECUTIVE BRIEF

Motion and Title: Staff recommends motion to adopt: a Resolution authorizing execution of an Agreement with the South Central Florida Express (SCFE) and the Florida Department of Transportation (FDOT) for the installation and maintenance of grade crossing traffic control devices at the SCFE crossing on S.W. Avenue E, Milepost 62.16, in Belle Glade.

SUMMARY: Adoption of this Resolution will approve an agreement for installation and maintenance of grade crossing traffic control devices at the SCFE crossing on S.W. Avenue E, Milepost 62.16. The FDOT has set aside Federal Rail Title II Signal Safety Funding for safety improvements to this crossing. The SCFE will install or have installed these improvements and the FDOT will reimburse the SCFE for all construction costs. Palm Beach County holds the license agreement for this crossing and will continue to pay 50 percent of the annual signal maintenance fees which is currently \$1,701 for this Type III, Class IV crossing.

District 6 (MRE)

Background and Justification: The South Central Florida Express (SCFE) is having grade crossing traffic control devices upgraded at the subject grade crossing. The SCFE will perform all work associated with the installation and the Florida Department of Transportation will reimburse the SCFE for all material and construction costs. The SCFE will be responsible for maintenance and operation of the devices. Palm Beach County (County) holds the license agreement and all activities must be coordinated with the license holder. The County will continue to pay 50 percent of the annual signal maintenance fee which is currently \$1,701, and all of the future maintenance and adjustment costs of said devices.

This office, having reviewed said Agreement, recommends the Board of County Commissioners adopt the accompanying Resolution authorizing execution of the Agreement.

Attachments:

1. Location Map
2. Resolution (3)
3. Agreements (6)
4. Affidavit of Corporate Secretary

Recommended By: Charles Rich
Division Director

1/19/12 [Signature]
Date

Approved By: A. J. Wade
County Engineer

2/6/12
Date

II. FISCAL IMPACT ANALYSIS

A. Five Year Summary of Fiscal Impact:

Fiscal Years	2012	2013	2014	2015	2016
Capital Expenditures	\$ 0	\$ 0	\$ 0	\$ 0	\$ 0
Operating Costs	0	0	0	0	0
External Revenues	-0-	-0-	-0-	-0-	-0-
Program Income (County)	-0-	-0-	-0-	-0-	-0-
In-Kind Match (County)	-0-	-0-	-0-	-0-	-0-
NET FISCAL IMPACT	*\$ 0	\$ 0	\$ 0	\$ 0	\$ 0
# ADDITIONAL FTE					
POSITIONS (Cumulative)					

Is Item Included in Current Budget? Yes X No

Budget Account No:

Fund 1201 Dept 360 Unit 2270 Object 4607

Recommended Sources of Funds/Summary of Fiscal Impact:

County Transportation Trust Fund
 Railroad Crossing Maintenance

Maintenance Costs \$1,701.00 per year

Fully funded within current budget for FY 2012. Future funding pending annual budget approval.

C. Departmental Fiscal Review:

Alicia Rovalainen

III. REVIEW COMMENTS

A. OFMB Fiscal and/or Contract Dev. and Control Comments:

* No additional fiscal impact.

OFMB

2/28/2012
2/7/12
2/7/12
cc
2/7/12

Contract Dev. and Control

2-9-12 B. Wheeler

This Contract complies with our contract review requirements.

B. Approved as to Form and Legal Sufficiency:

Martine Pluss *2/24/12*
 Assistant County Attorney

C. Other Department Review:

 Department Director

This summary is not to be used as a basis for payment.

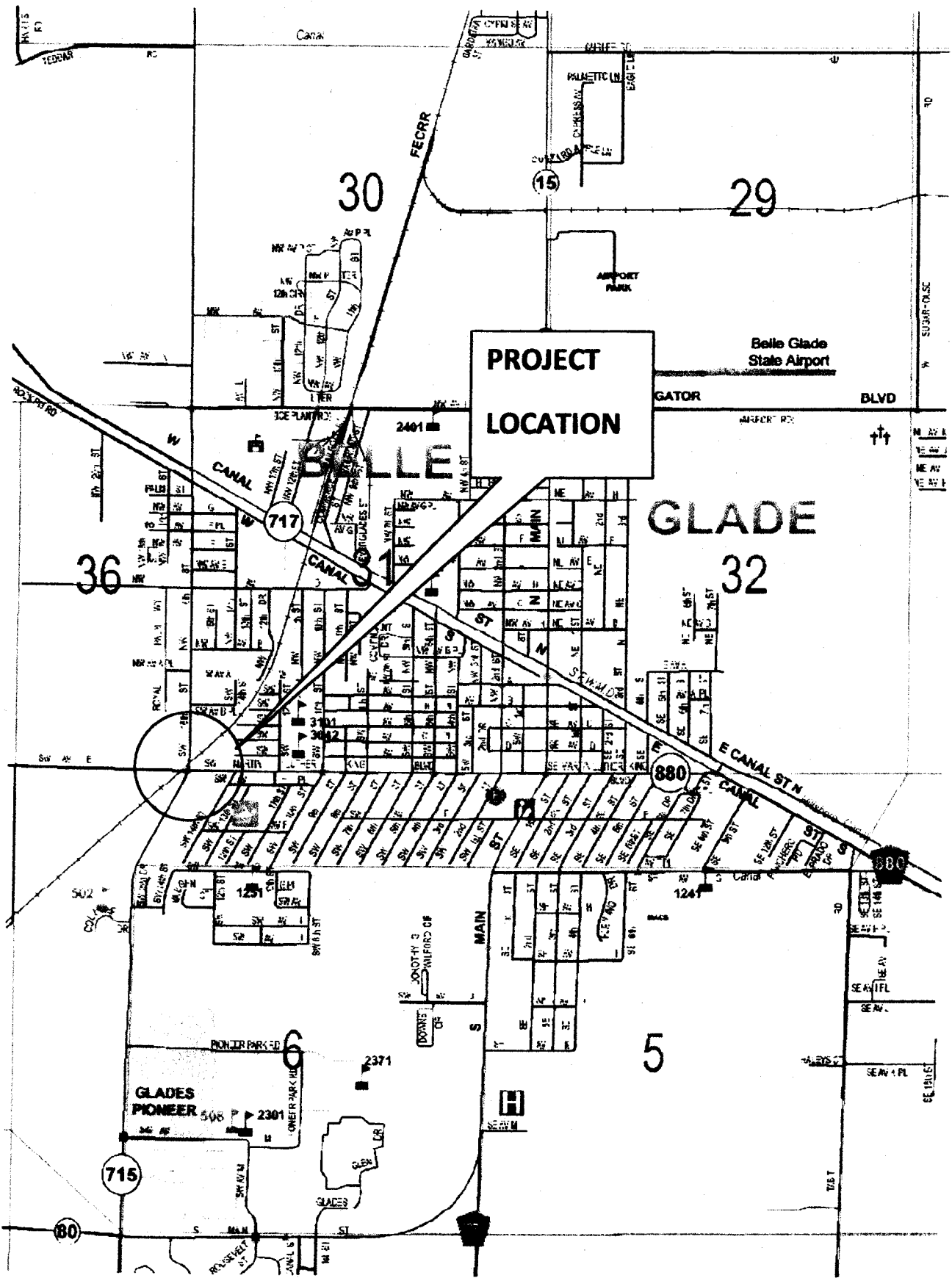

**SW AVENUE E AT THE SOUTH CENTRAL FLORIDA EXPRESS
RAILWAY CROSSING**

ATTACHMENT 1

RESOLUTION NO. R-2012 _____

**RESOLUTION OF THE BOARD OF COUNTY
COMMISSIONERS OF PALM BEACH COUNTY, FLORIDA
AUTHORIZING EXECUTION OF A RAILROAD
AGREEMENT WITH THE FLORIDA DEPARTMENT OF
TRANSPORTATION AND THE SOUTH CENTRAL
FLORIDA EXPRESS, INC. FOR SAFETY IMPROVEMENTS
AT THE S.W. AVENUE "E" RAILWAY CROSSING**

WHEREAS, the Florida Department of Transportation (FDOT) is having constructed, reconstructed or is otherwise changing a portion of the Public Road System on S.W. Avenue "E" which shall call for the installation of railroad grade crossing traffic control devices for the railroad grade crossing over S.W. Avenue "E"; and

WHEREAS, the FDOT will fund safety improvements to S.W. Avenue "E" at the South Central Florida Express, Inc. (SCFE) crossing designated as Financial Project Number 43049615701 at Crossing Number 272313-P in Belle Glade, Florida and

WHEREAS, the SCFE's contractor, Progress Rail, will construct the safety improvements;
and

WHEREAS, Palm Beach County will continue to fund 50% (fifty percent) of the annual maintenance fees of \$3,402 or \$1,701 and all of the future maintenance and adjustment costs of said devices.

NOW, THEREFORE, BE IT RESOLVED BY THE BOARD OF COUNTY

COMMISSIONERS OF PALM BEACH COUNTY FLORIDA:

That Palm Beach County enter into a railroad agreement with FDOT and SCFE for the funding, construction and maintenance of the safety improvements, and

That the Chairman of the Board of County Commissioners be authorized to enter into such agreements with the FDOT and the SCFE, as herein described: and

That this RESOLUTION shall take effect immediately upon adoption.

RESOLUTION NO. 2012-
March 6, 2012

The foregoing Resolution was offered by Commissioner _____ who moved its adoption. The motion was seconded by Commissioner _____ and upon being put to a vote was as follows:

Commissioner Shelley Vana, Chair	-
Commissioner Steven L. Abrams, Vice Chairman	-
Commissioner Karen T. Marcus, Chair	-
Commissioner Paulette Burdick	-
Commissioner Burt Aaronson	-
Commissioner Jess R. Santamaria	-
Commissioner Priscilla A. Taylor	-

The Chairperson thereupon declared the resolution duly passed and adopted _____.

SHARON R. BOCK, CLERK & COMPTROLLER

By: _____
Deputy Clerk

S E A L

APPROVED AS TO FORM
AND LEGAL SUFFICIENCY

By: _____
(County Attorney)

STATE OF FLORIDA DEPARTMENT OF TRANSPORTATION

**RAILROAD REIMBURSEMENT AGREEMENT
GRADE CROSSING TRAFFIC CONTROL DEVICES - COUNTY**

725-090-27
RAIL
OGC - 03/11

FINANCIAL PROJECT NO.	ROAD NAME OR NUMBER	COUNTY NAME	PARCEL & R/W NUMBER	FAP NUMBER
43049615701	S.W. AVE "E"	PALM BEACH	930006915	00S4-048

THIS AGREEMENT, made and entered into this _____ day of _____, by and between the STATE OF FLORIDA DEPARTMENT OF TRANSPORTATION, hereinafter called the DEPARTMENT, and SOUTH CENTRAL FLORIDA EXPRESS, INC a corporation organized and existing under the laws of State of Florida with its principal place of business in the City of Clewiston, County of Palm Beach State of Florida, hereinafter called the COMPANY; and PALM BEACH County, a political subdivision of the State of Florida, acting by and through its Board of County Commissioners, hereinafter called the COUNTY.

WITNESSETH:

WHEREAS, the DEPARTMENT is constructing, reconstructing or otherwise changing a portion of the Public Road System, designated by the Financial Project ID 43049615701 on S.W. AVE "E", which crosses at grade the right of way and tracks of the COMPANY'S Milepost 62.16 FDOT/AAR Crossing Number 272313-P, at or near S.W.AVE "E" as shown on DEPARTMENT'S Plan Sheet No. Track and Cable Plans, attached hereto as a part hereof; and

NOW, THEREFORE, in consideration of the mutual undertakings as herein set forth, the parties hereto agree as follows:

1. The COMPANY shall furnish the necessary materials and install Automatic Grade Crossing Signals Type III Class IV and/or other traffic control devices at said location on an actual cost basis and in accordance with (1) the attached detailed statement of the work, plans, and specifications; and (2) the DEPARTMENT'S Plans and Standard Index Number 17882 attached hereto and made a part hereof.
2. After installation of said signals is completed, fifty (50%) percent of the expense thereof in maintaining the same shall be borne by the COUNTY and fifty (50%) percent shall be borne by the COMPANY, as enumerated by the Schedule of Annual Cost of Automatic Highway Grade Crossing Devices attached hereto and by this reference made a part hereof and subject to future revision.
3. After said signals have been installed and found to be in satisfactory working order by the parties hereto, the same shall be immediately put into service, operated and maintained by the COMPANY so long as said COMPANY or its successors or assigns shall operate the said signals at said grade crossing; or until it is agreed between the parties hereto that the signals are no longer necessary or until the said crossing is abandoned; or legal requirements occur which shall cease operation of signals thereat.

The COMPANY agrees that any future relocation or adjustment of said signals shall be performed by the COMPANY, but at the expense of the party initiating such relocation. Upon relocation the maintenance responsibilities shall be in accordance with the provisions of this agreement. It is further agreed that the cost of maintaining any additional or replacement signal equipment at the same location will be shared as provided under Paragraph 2. above.

4. Unless otherwise agreed upon herein, the COUNTY agrees to insure that at the crossing the advance warning signs and railroad crossing pavement markings will conform to the U.S. Department of Transportation Manual on Uniform Traffic Control Devices within 30 days of notification that the railroad signal improvements have been completed and that such signs and pavement markings will be continually maintained at an acceptable level.

5. The COMPANY hereby agrees to install and/or adjust the necessary parts of its facilities along said road in accordance with the provisions set forth in the:

(a) DEPARTMENT Procedure No. 725-080-002 Appendix D.4, and Rule 14.57.011 "Public Railroad-Highway Grade Crossing Costs", Florida Administrative Code.

(b) Federal Highway Administration Federal-Aid Policy Guide, 23 C.F.R. Subchapter G, Part 646, Subpart B, and 23 C.F.R., Subchapter B, Part 140, Subpart I,

and any supplements thereto or revisions thereof, which, by reference hereto, are made a part hereof. The COMPANY further agrees to do all of such work, with its own forces or by a contractor paid under a contract let by the COMPANY, all under the supervision and approval of the DEPARTMENT and the Federal Highway Administration, when applicable.

6. The DEPARTMENT hereby agrees to reimburse the COMPANY for all costs incurred by it in the installation and/or adjustment of said facilities, in accordance with the provisions of Procedure No. 725-080-002 Appendix D-4 "Billing Requirements," and any supplements thereto or revisions thereof. It is understood and agreed by and between the parties hereto that preliminary engineering costs not incorporated within this agreement shall not be subject to payment by the DEPARTMENT.

7. Attached hereto, and by this reference made a part hereof, are plans and specifications of the work to be performed by the COMPANY pursuant to the terms hereof, and an itemized estimate of the cost thereof in the amount of \$ 102,392.00. All work performed by the COMPANY pursuant hereto, shall be performed according to these plans and specifications as approved by the DEPARTMENT and the Federal Highway Administration if federal aid participating; and all subsequent plan changes shall likewise be approved by the DEPARTMENT and the Federal Highway Administration, when applicable.

8. All labor, services, materials, and equipment furnished by the COMPANY in carrying out the work to be performed hereunder shall be billed by the COMPANY direct to the DEPARTMENT. Separate records as to the costs of

contract bid items and force account items performed for the COMPANY shall also be furnished by the COMPANY to the DEPARTMENT.

9. The COMPANY has determined that the method to be used in developing the relocation or installation cost shall be as specified for the method checked and described hereafter:

- (a) Actual and related indirect costs accumulated in accordance with a work order accounting procedure prescribed by the applicable Federal or State regulatory body.
- (b) Actual and related indirect costs accumulated in accordance with an established accounting procedure developed by the COMPANY and approved by the DEPARTMENT.
- (c) An agreed lump sum \$ 0.00 , as supported by a detail analysis of estimated cost attached hereto. (NOTE: This method is not applicable where the estimated cost of the proposed adjustment exceeds \$100,000.)

10. The installation and/or adjustment of the COMPANY'S facility as planned will will not involve additional work over and above the minimum reimbursable requirements of the DEPARTMENT. (If upgrading and/or nonreimbursable work is involved at the option of the COMPANY, then credit against the cost of the project is required and will be governed by the method checked and described hereafter):

- (a) _____ % will be applied to the final billing of work actually accomplished to determine required credit for (betterment) and/or (expired service life) and/or (nonreimbursable segments).
- (b) All work involving nonreimbursable segments will be performed by special COMPANY work or job order number apart and separate from the reimbursable portion of the work; such work or job order number to be _____. The COMPANY further agrees to clearly identify such additional work areas in the COMPANY'S plans and estimates for the total work covered by this Agreement.
- (c) \$ 0.00 credited for betterment expired service life
 nonreimbursable segments in accord with Article 9.(c) hereinabove.

11. It is specifically agreed by and between the DEPARTMENT and the COMPANY that the DEPARTMENT shall receive fair and adequate credit for any salvage which shall accrue to the COMPANY as a result of the above installation and/or adjustment work.

12. It is further agreed that the cost of all improvements made during this adjustment work shall be borne by the COMPANY, subject only to the DEPARTMENT bearing such portion of this cost as represents the cost of adjustment of previously existing facility, less salvage credit as set forth in the immediately preceding paragraph.

13. Upon completion of the work the COMPANY shall, within one hundred eighty (180) days, furnish the DEPARTMENT with two (2) copies of its final and complete billing of all costs incurred in connection with the work performed hereunder, such statement to follow as closely as possible the order of the items contained in the estimate attached hereto. The totals for labor, overhead, travel expense, transportation, equipment, material and supplies, handling costs and other services shall be shown in such a manner as will permit ready comparison with the approved plans and estimates. Materials shall be itemized where they represent major components of cost in the relocation following the pattern set out in the approved estimate as closely as is possible. Salvage credits from recovered and replaced permanent and recovered temporary materials shall be reported in said bills in relative position with the charge for the replacement or the original charge for temporary use.

The final billing shall show the description and site of the Project; the date on which the first work was performed, or, if preliminary engineering or right-of-way items are involved, the date on which the earliest item of billed expense was incurred; the date on which the last work was performed or the last item of billed expense was incurred; and the location where the records and accounts billed can be audited. Adequate reference shall be made in the billing to the COMPANY'S records, accounts and other relevant documents. All cost records and accounts shall be subject to audit by a representative of the DEPARTMENT. Upon receipt of invoices, prepared in accordance with the provisions of the above indicated Reimbursement Policy, the DEPARTMENT agrees to reimburse the COMPANY in the amount of such actual costs as approved by the DEPARTMENT'S auditor.

14. Payment shall be made only after receipt and approval of goods and services unless advance payments are authorized by the DEPARTMENT'S Comptroller under Section 334.044(29), F.S., or by the Department of Financial Services under Section 215.422(14), Florida Statutes (F.S.).

15. In accordance with Section 287.058, Florida Statutes, the following provisions are in this Agreement: If this Contract involves units of deliverables, then such units must be received and accepted in writing by the Contract Manager prior to payments. Bills for fees or other compensation for services or expenses shall be submitted in detail sufficient for a proper preaudit and postaudit thereof.

16. Bills for travel expenses specifically authorized in this agreement shall be submitted and paid in accordance with DEPARTMENT Rule 14-57.011 "Public Railroad-Highway Grade Crossing Costs" and the Federal Administration Federal-Aid Policy Guide, Subchapter B, Part 140, Subpart I "Reimbursement for Railroad Work."

17. In accordance with Section 215.422, Florida Statutes, the following provisions are in this Agreement: Contractors providing goods and services to the DEPARTMENT should be aware of the following time frames. Upon receipt, the DEPARTMENT has five (5) working days to inspect and approved the goods and services, unless the Agreement specifies otherwise. The DEPARTMENT has 20 days to deliver a request for payment (voucher) to the DEPARTMENT of Financial Services. The 20 days are measure from the latter of the date the invoice is received or the goods or services are received, inspected and approved.

If a payment is not available within 40 days, a separate interest penalty at a rate as established pursuant to Section 215.422(3)(b), Florida Statutes, will be due and payable, in addition to the invoice amount, to the Contractor. Interest penalties of less than one (1) dollar will not be enforced unless the Contractor requests payment. Invoices which have to be returned to a Contractor because of Contractor preparation errors will result in a delay in the payment. The invoice payment requirements do not start until a properly completed invoice is provided to the DEPARTMENT.

A Vendor Ombudsman has been established within the Department of Financial Services. The duties of this individual include acting as an advocate for contractors/vendors who may be experiencing problems in obtaining timely payment(s) from a state agency. The Vendor Ombudsman may be contacted at (850) 413-5516.

18. Records of costs incurred under terms of this Agreement shall be maintained and made available upon request to the DEPARTMENT at all times during the period of this Agreement and for five years after final payment is made. Copies of these documents and records shall be furnished to the DEPARTMENT upon request. Records of costs incurred includes the Contractor's general accounting records and the project records, together with supporting documents and records, of the Contractor and all subcontractors performing work on the project, and all other records of the Contractor and subcontractors considered necessary by the DEPARTMENT for a proper audit of costs.

19. In the event this contract is for services in excess of TWENTY FIVE THOUSAND DOLLARS (\$25,000.00) and a term for a period of more than one year, the provisions of Section 339.135(6)(a), Florida Statutes, are hereby incorporated:

The DEPARTMENT during any fiscal year, shall not expend money, incur any liability, or enter into ny contract which, by its terms, involves the expenditure of money in excess of the amounts budgeted as available for expenditure during such fiscal year. Any contract, verbal or written, made in violation of this subsection is null and void, and no money may be paid on such contract. The DEPARTMENT hall require a statement from the Comptroller of the DEPARTMENT that such funds are available prior to entering into any such contract or other binding commitment of funds. Nothing herein contained shall prevent the making of contracts for periods exceeding one year, but any contract so made shall be executor only for the value of the services to be rendered or agreed to be paid for in succeeding fiscal years; and this paragraph shall be incorporated verbatim in all contracts of the DEPARTMENT which are for an amount in excess of TWENTY FIVE THOUSAND DOLLARS (\$25,000.00) and which have a term for a period of more than one year.

20. In accordance with Section 287.133(2)(a), Florida Statutes, the following provisions are included in this Agreement:

A person or affiliate who has been placed on the convicted vendor list following a conviction for a public entity crime may not submit a bid, proposal, or reply on a contract to provide any goods or services to a public entity; may not submit a bid, proposal, or reply on a contract with a public entity for the construction or repair of a public building or public work; may not submit bids, proposals, or replies on leases of real property to a public entity; may not be awarded or perform work as a contractor, supplier, subcontractor, or consultant under a contract with any public entity; and may not transact business with any public entity in excess of the threshold amount provided in s.287.017 for CATEGORY TWO for a period of 36 months following the date of being placed on the convicted vendor list.

21. In accordance with Section 287.134(2)(a), Florida Statutes, the following provisions are included in this Agreement:

An entity or affiliate who has been placed on the discriminatory vendor list may not submit a bid, proposal, or reply on a contract to provide any goods or services to a public entity; may not submit a bid, proposal, or reply on a contract with a public entity for the construction or repair of a public building or public work; may not submit bids, proposals, or replies on leases of real property to a public entity; may not be awarded or perform work as a contractor, supplier, subcontractor, or consultant under a contract with any public entity; and may not transact business with any public entity.

22. In accordance with Section 287.0582, Florida Statutes, the following provision is included in this Agreement:

The DEPARTMENT'S obligation to pay under this contract is contingent upon an annual appropriation by the Florida Legislature.

23. The COMPANY covenants and agrees that it will indemnify and hold harmless the DEPARTMENT and all of the DEPARTMENT'S officers, agents, and employees from any claim, loss, damage, cost charge, or expense arising out of any act, action, neglect, omission or delay by the COMPANY during the performance of the contract, whether direct or indirect, and whether to any person or property to which the DEPARTMENT or said parties may be subject, except that neither the COMPANY nor any of its sub-contractors will be liable under this section for damages arising out of injury or damage to persons or property directly caused or resulting from the sole negligence of the DEPARTMENT or any of its officers, agents, or employees.

24. COMPANY shall:

1. utilize the U.S. Department of Homeland Security's E-Verify system to verify the employment eligibility of all new employees hired by the COMPANY during the term of the contract; and
2. include an express requirement in any subcontract that subcontractors performing work or providing services pursuant to the state contract utilize the U.S. Department of Homeland Security's E-Verify system to verify the employment eligibility of all new employees hired by the subcontractor during the contract term.

IN WITNESS WHEREOF, the parties hereto have caused these presents to be executed by their duly authorized officers, the day and year first written above.

PALM BEACH COUNTY, a Political
Subdivision of the State of Florida Board of
County Commissioners

By: _____
Chair - Shelley Vana

ATTEST:
SHARON R. BOCK
CLERK & COMPTROLLER

By: _____
Clerk

APPROVED AS TO FORM
AND LEGAL SUFFICIENCY

COUNTY ATTORNEY

APPROVED AS TO TERMS

ENGINEER
By: Charles Rich

STATE OF FLORIDA
DEPARTMENT OF TRANSPORTATION

By: _____
Director of Transportation Development

Legal Review

By: _____
Attorney - DOT Date

SOUTH CENTRAL FLORIDA EXPRESS,
INC.

By: Kmcluffe

STATE OF FLORIDA DEPARTMENT OF TRANSPORTATION
WORK DESCRIPTION
GRADE CROSSING TRAFFIC CONTROL DEVICES

725-090-09
 RAIL
 05/02

FINANCIAL PROJECT NO.	ROAD NAME OR NUMBER	COUNTY NAME	PARCEL & R/W NUMBER	FAP NUMBER
43049615701	S.W AVE "E"	PALM BEACH	930006915	00S4-048

RAILROAD COMPANY

SOUTH CENTRAL FLORIDA EXPRESS, INC

A. JOB DESCRIPTION & LOCATION: FL&G, MAST, LED LIGHTS & HXP-3R SYSTEM

B. TYPE OF ROADWAY FACILITY: _____

C. FDOT/AAR XING NO.: 272313-P RR MILE POST TIE: 62.16

D. TYPE CROSSING PROPOSED: III CLASS: IV DOT INDEX NO.: 178826

E. STATUS AND PROPOSAL:

1. EXISTING DEVICES: (See Agreement dated _____)
- a. None-New Crossing.
 - b. Crossbuck and Disk.
 - c. Flashing Signals with Disk.
 - d. Flashing Signals with Cantilever.
 - e. Flashing Signals with Gates.
 - f. Flashing Signals with Cantilever and Gates.

2. PROPOSED DEVICES: (Safety Index Rating 66.31)
- a. No revision required.
 - b. Crossbuck and Disk.
 - c. Flashing Signals and Disk.
 - d. Flashing Signals with Cantilever.
 - e. Flashing Signals with Gates.
 - f. Flashing Signals with Cantilever and Gates.
 - g. Relocate existing signal devices:
 - (1) (With-Without) addition of Gates.
 - (2) (With-Without) synchronization with highway traffic signals.
 - (3) (With-Without) constant warning time.

F. COMMUNICATION AND/OR POWER LINE ADJUSTMENTS

- 1. By Others (_____ Company.)
- 2. By Railroad Company.

G. AUTHORITY REQUESTED: (Draft attached: Yes No.)

- 1. Agreement (Third Party Participating PLAM BEACH COUNTY)
- 2. Supplemental Agreement No. _____
- 3. Crossing Permit.
- 4. Estimate for Change Order No. _____
- 5. Letter of Authority.
- 6. Letter of Confirmation (No Cost to Department).

H. OTHER REMARKS:

Negotiations to be completed by: _____

Signal installation target date: _____

Synchronization: (Draft attached Yes No.)

STATE OF FLORIDA DEPARTMENT OF TRANSPORTATION
RAILROAD GRADE CROSSING TRAFFIC CONTROL DEVICES

725-090-41
 RAIL
 OGC - 01/11

FINANCIAL PROJECT NO.	ROAD NAME OR NUMBER	COUNTY NAME	PARCEL & R/W NUMBER	FAP NUMBER
43049615701	S.W. AVE "E"	PALM BEACH	930006915	00S4-048

COMPANY NAME: SOUTH CENTRAL FLORIDA EXPRESS, INC.

A. FDOT/AAR XING NO.: 272313-P RR MILE POST TIE: 62.16

B. TYPE SIGNALS PROPOSED III CLASS IV DOT INDEX: 17882

**SCHEDULE OF ANNUAL COST OF AUTOMATIC
 HIGHWAY GRADE CROSSING TRAFFIC CONTROL DEVICES**

Annual Maintenance Cost Exclusive of Installation

<u>CLASS</u>	<u>DESCRIPTION</u>	<u>COST*</u>
I	Flashing Signals - One Track	\$2,256.00
II	Flashing Signals - Multiple Tracks	\$2,985.00
III	Flashing Signals and Gates - One Track	\$3,402.00
IV	Flashing Signals and Gates - Multiple Tracks	\$4,272.00

AUTHORITY: FLORIDA ADMINISTRATIVE RULE 14-57.011
 Public Railroad-Highway Grade Crossing Costs

EFFECTIVE DATE: July 22, 1982

GENERAL AUTHORITY: 334.044, F.S.

SPECIFIC LAW IMPLEMENTED: 335.141, F.S.

*This schedule will become effective July 1, 2011 and will be reviewed every 5 years and revised as appropriate based on the Consumer Price Index for all Urban Consumers published by the U.S. Department of Labor.

Keane, Thomas

From: The job FI989WMMR
Sent: Friday, April 22, 2011 2:55 PM
To: Keane, Thomas
Subject: FUNDS APPROVAL/REVIEWED FOR CONTRACT AQ905

STATE OF FLORIDA DEPARTMENT OF TRANSPORTATION
FUNDS APPROVAL

Contract #AQ905 Contract Type: AA Method of Procurement: R
Vendor Name: FLORIDA EAST COA
Vendor ID: VF596001115004
Beginning date of this Agmt: 04/22/11
Ending date of this Agmt: 12/31/15
Contract Total/Budgetary Ceiling: ct = \$102,392.00

Description:
Title II Signal Safety Program SW Avenue "E" @ FEC Railway

ORG-CODE *EO *OBJECT *AMOUNT *FIN PROJECT *FCT *CFDA
(FISCAL YEAR) *BUDGET ENTITY *CATEGORY/CAT YEAR
AMENDMENT ID *SEQ. *USER ASSIGNED ID *ENC LINE(6S)/STATUS

Action: ORIGINAL Funds have been: APPROVED

55	042010429	*PT	*563014	*	102392.00	*43049615701	*127	*20.205
2011			*55100100			*088808/11		
0001			*00	*		*0001/04		

TOTAL AMOUNT: *\$ 102,392.00 *

FUNDS APPROVED/REVIEWED FOR ROBIN M. NAITOVE, CPA, COMPTROLLER
DATE: 04/22/2011

STATE OF FLORIDA
 DEPARTMENT OF TRANSPORTATION
 RAILROAD SIGNAL SAFETY PROGRAM

STATE PROJECT NO.
 S3000 - 6918

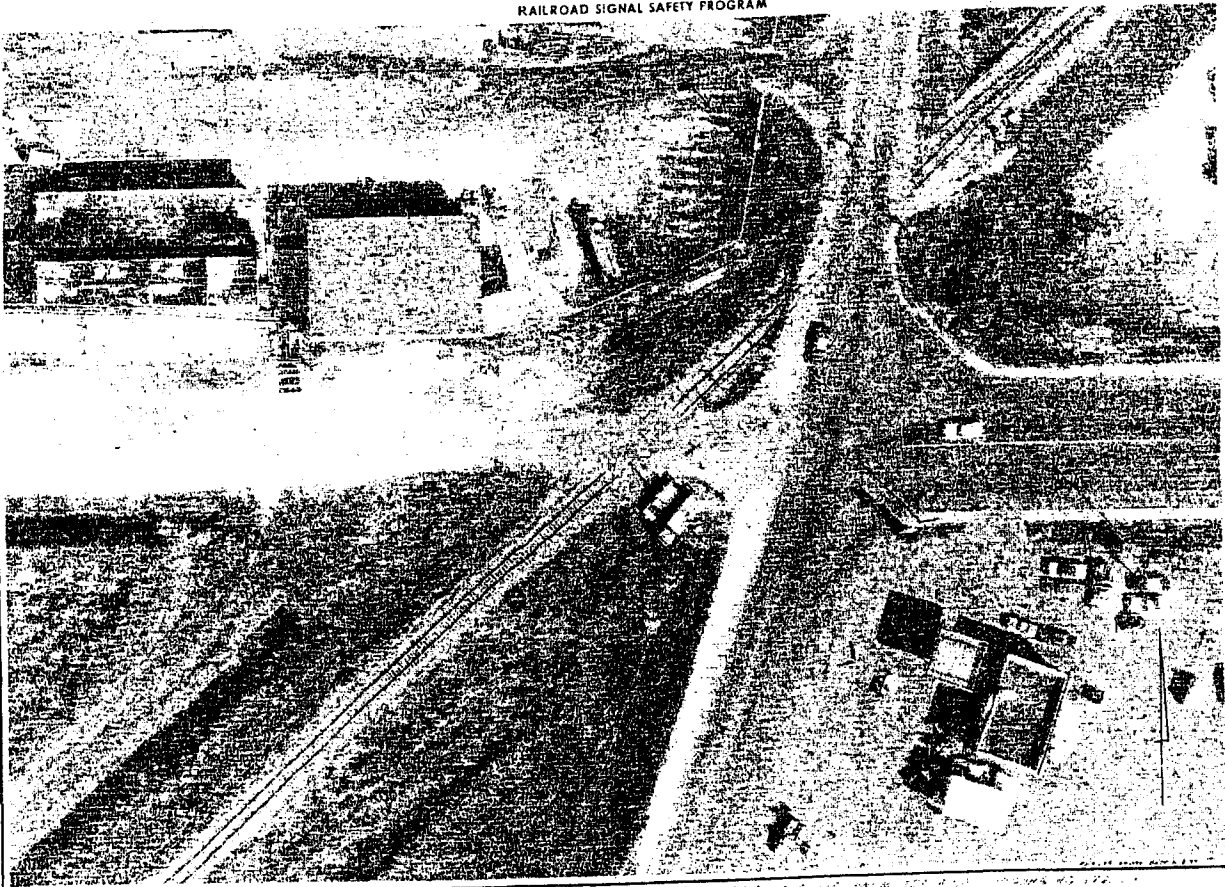
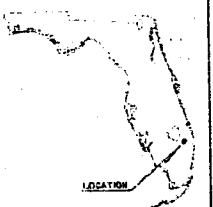

RAILROAD CROSSING MAP	
STATE ROAD	S.W. 1st AVE.
COUNTY	PALM BEACH
SECTION	S3000 - 6918
CROSSING NUMBER	STREET #
PROPOSED TYPE	THRU CROSSING
FAP NO.	S.P.D. - 0000 (M)

SOUTH

NORTH

START 2520'
30 SECS. @ 35 MPH
(INCLUDES 4 SEC. FOR HXP3R)
(INCLUDES 15 SEC. FOR PRE-EMPTION)

START 2520'
30 SECS. @ 35 MPH
(INCLUDES 4 SEC. FOR HXP3R)
(INCLUDES 15 SEC. FOR PRE-EMPTION)

AVENUE "E"

SOUTHWEST 16TH STREET

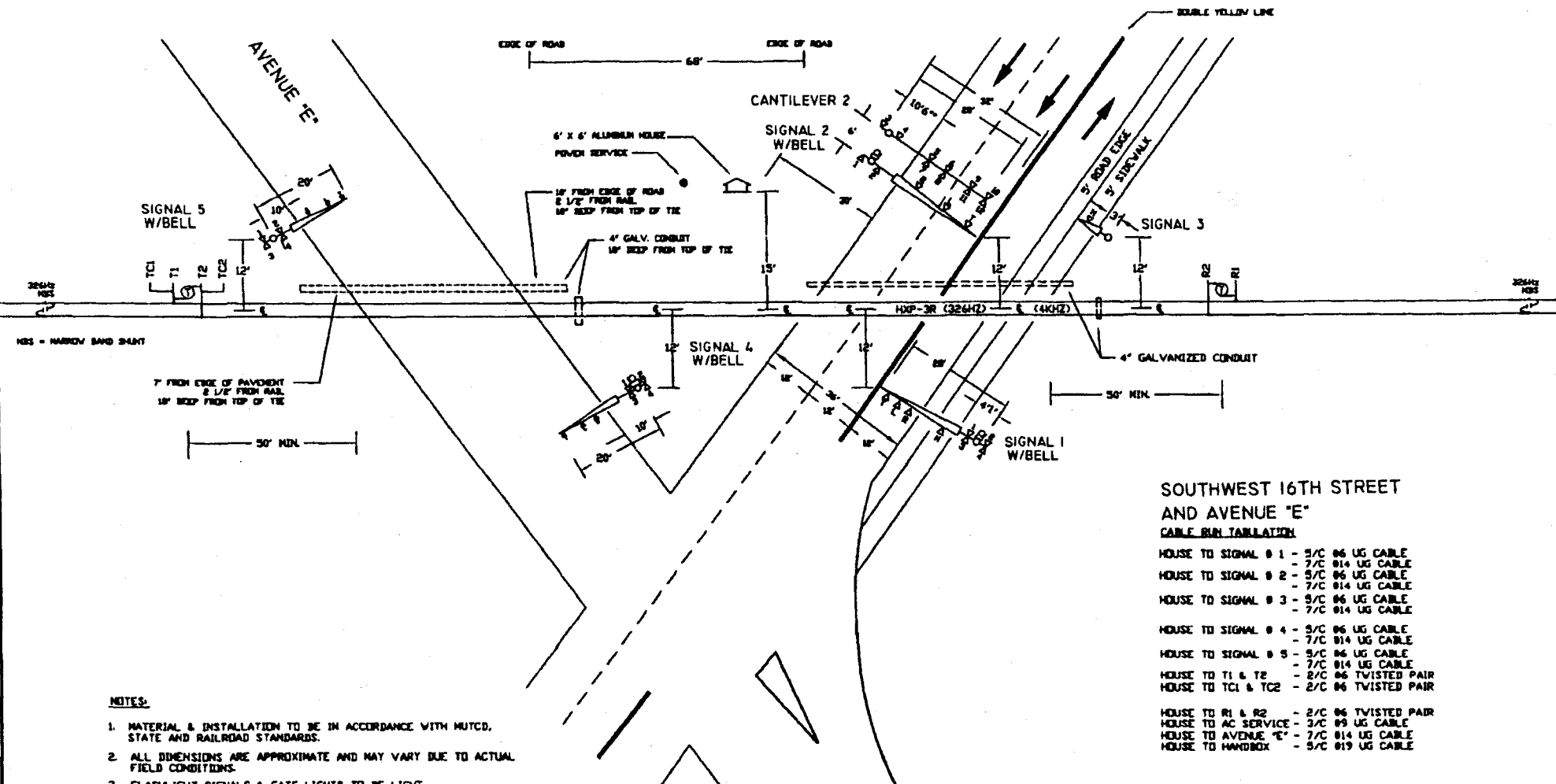

SOUTHWEST 16TH STREET AND AVENUE "E"

CABLE RUN TABULATION

- HOUSE TO SIGNAL # 1 - 5/C 06 UG CABLE
- HOUSE TO SIGNAL # 2 - 5/C 06 UG CABLE
- HOUSE TO SIGNAL # 3 - 5/C 06 UG CABLE
- HOUSE TO SIGNAL # 4 - 5/C 06 UG CABLE
- HOUSE TO SIGNAL # 5 - 5/C 06 UG CABLE
- HOUSE TO T1 & T2 - 2/C 06 TWISTED PAIR
- HOUSE TO TCI & TC2 - 2/C 06 TWISTED PAIR
- HOUSE TO R1 & R2 - 2/C 06 TWISTED PAIR
- HOUSE TO AC SERVICE - 3/C 09 UG CABLE
- HOUSE TO AVENUE "E" - 7/C 014 UG CABLE
- HOUSE TO HANDBOX - 5/C 019 UG CABLE

- NOTES:
1. MATERIAL & INSTALLATION TO BE IN ACCORDANCE WITH MUTCD, STATE AND RAILROAD STANDARDS.
 2. ALL DIMENSIONS ARE APPROXIMATE AND MAY VARY DUE TO ACTUAL FIELD CONDITIONS.
 3. FLASHLIGHT SIGNALS & GATE LIGHTS TO BE LIGHT EMITTING DIODE ASSEMBLIES, (LED).
 4. TD DENOTES TWIST PAIR.

AS WIRED 9/18/07 AS INSTALLED 7/10/11

REVISIONS:
1) ADD AVE "E" TO SW. 16 TH ST. HOUSE
2) ADD GATES TO AVENUE "E"

DJR SIGNAL SERVICES
3800 TEN OAKS ROAD
SUITE B
P.O. BOX 305
GLENELG, MARYLAND
21737-0305
(800) 867-2118



SOUTH CENTRAL FLORIDA EXPRESS RAILROAD CROSSING WARNING DEVICES	
SCALE: NONE	APPROVED BY: [Signature]
DATE: 8/1/07	REVISION: NONE
SW 16TH STREET (AVE E) - DOT #272 312H BELLE GLADE, PALM BEACH COUNTY, FL	
TRACK & CABLE PLAN	DRAWING NUMBER 2715274

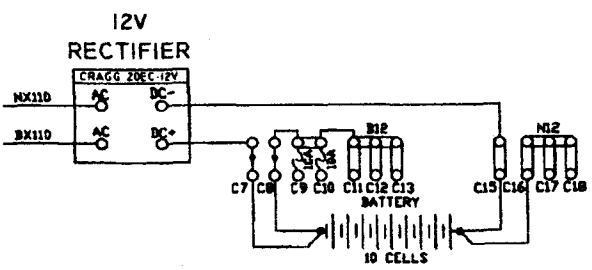
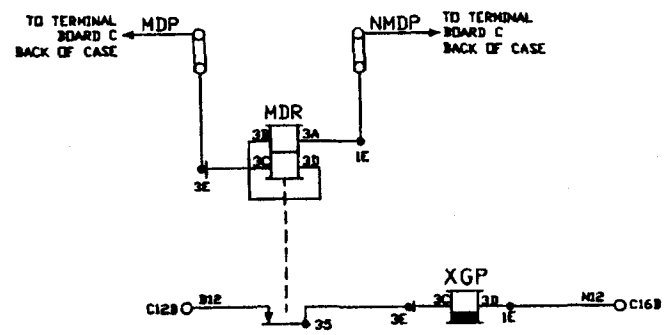
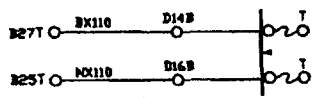
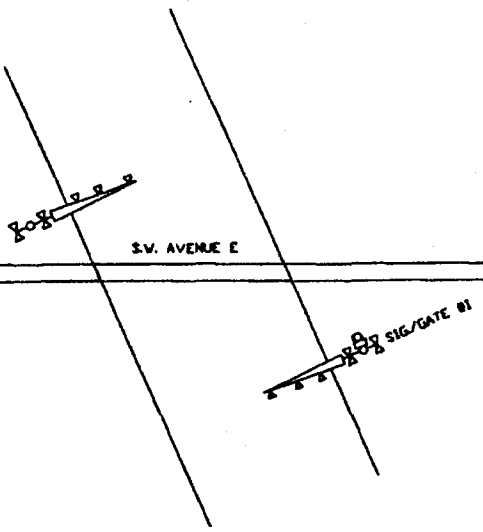

AS WIRED 7/7/11 AS INSTALLED 7/11/11

DJR SIGNAL SERVICES 3800 TEN OAKS ROAD SUITE B P.O. BOX 305 GLENELG, MARYLAND 21737-0305 (800) 867-2118	SOUTH CENTRAL FLORIDA EXPRESS RAILROAD CROSSING WARNING DEVICES		
	RECALD: NONE DATE: 5/31/09	APPROVED BY: *As Required - Rev. PRC-1-037* REVISIONS	DRAWN BY: DJR
	S.W. AVENUE E - DOT #272 313P BELLE GLADE, PALM BEACH COUNTY, FL		
A DIVISION OF PROGRESS RAILSERVICES		DRAWING NUMBER 6216	

CIRCUIT PLAN "A"

STATE OF FLORIDA
DEPARTMENT OF TRANSPORTATION

OFFICE OF MODAL DEVELOPMENT
DISTRICT 4 RAIL OFFICE

PROJECT SCOPE AND COST ESTIMATE

PROJECT INFORMATION

Financial Project No.: 430496-1-57-01
FAP No.: 00S4-048
Location: S.W. AVE "E"
County: Palm Beach
Crossing No.: 272313-P
RR MP: 62.16
Company: South Central Florida Express, Inc.

This project scope and cost estimate was prepared by:
District Rail Coordinator

PROJECT SCOPE AND COST ESTIMATE

Installation of FLG, Mast, LED's, CWT (HXP-3R) Controller System.... \$102,392.00

TOTAL PROJECT COST..... \$102,392.00

Keane, Thomas

From: Grabloski, Ron
Sent: Wednesday, March 30, 2011 11:23 AM
To: Keane, Thomas
Cc: Adams, Antonette; Simpson, Jo; Lamey, Cassandra
Subject: FW: Modification of D4 Signal Safety Program

Tom – Here are your FM numbers for the new rail crossing projects. As Scott has said the funds won't be transferred until April, I have left these projects as candidates. I am assuming that budget will also be transferred with the funds. As soon as the funds and budget are received, I will get these projects adopted. In order to get the Federal Aid Project numbers assigned, you will have to forward (electronically) location maps to Cassandra.

Ron.....

430494-1-57-01	628117W	CSX	15th Street
430497-1-57-01	272548A	FEC	NE 13th Street
430495-1-57-01	272277W	FEC	Conner's Highway
430496-1-57-01	272313P	FEC	SW Avenue "E"
430498-1-57-01	272301V	FEC	Orange Avenue

From: Allbritton, Scott
Sent: Thursday, March 17, 2011 12:43 PM
To: Hartmann, Hector; Keane, Thomas
Cc: Simpson, Jo; Grabloski, Ron; Sheffield, Kendra; Luten, Richard; Swearingen, Marilyn; Bradley, Ginny; Lapkowski, Annette
Subject: Modification of D4 Signal Safety Program

The following projects have been selected for modification of Four's current year Railroad Signal Safety Improvement Program:

<u>Crossing</u>	<u>R/R</u>	<u>Roadway</u>	<u>City</u>	<u>County</u>	<u>Scope</u>	<u>Estimate</u>	<u>Funding</u>
628117W	CSX	15th Street	West Palm Beach	Palm Beach	LEDs	10,763	RHH
272548A	FEC	NE 13th Street	Ft. Lauderdale	Broward	LEDs/CWT	94,250	RHH
272277W	FEC	Conner's Highway	Tequesta	Palm Beach	FL&G, LEDs	84,853	RHH
272313P	FEC	SW Avenue "E"	Belle Glade	Palm Beach	FL&G	102,392	RHH
272301V	FEC	Orange Avenue	Belle Glade	Palm Beach	FL&G, Motion	149,722	RHH
						441,980	

This information has been provided for planning purposes. Funds will be transferred to your District at the beginning of April.

Request the Federal-Aid number form Richard Luten.

Programming:

<u>Transportation System</u>	<u>WorkMix</u>	<u>Phase</u>	<u>Fiscal Year</u>	<u>Fund</u>	<u>Program</u>
05-Non-Intrastate State Hwy	8335	57	2011	RHH	53
06 - Non-Intrastate Off State Hwy, or					
16-Off State Hwy Sys/Off Fed Sys					

Let me know if you have any questions.

Scott Allbritton, Rail Signals and Contracts, (850) 414-4553



(800) 867-2118

8/27/2010

CONFIDENTIAL

Page 1 of 2

ENGINEER'S ESTIMATE & MATERIAL LIST

RAILROAD: SOUTH CENTRAL FLORIDA EXPRESS

LOCATION: S. W. AVENUE "E"
 DOT # 272 313P, M.P.062.16
 BELLE GLADE, PALM BEACH COUNTY, FL

PROJECT: INSTALLATION OF RAILROAD CROSSING WARNING SYSTEM
 REUSE EXISTING HOUSE AND COMPONENTS AT S. W. 16TH
 STREET WITH HXP-3R, 2 NEW GATES, MASTS, & NEW FLASHING
 LIGHTS. TRAIN SPEED IS 35 MPH.

CONTROL MATERIAL DESCRIPTION	SUPPLIER	QUANTITY
REUSE EXISTING HOUSE AT S. W. 16TH STREET WITH HXP-3R AND COMPONENTS		
DC Shunt Enhancer (T-RX7100)	GENESIS	1 ea.
Flasher Relay w/X PAK (A62-673) B48	GRS	1 ea.
Relay, POPR (A62-310)	GRS	1 ea.
Relay, GPR (A62-310)	GRS	1 ea.
Relay, XGPR (A62-360)	GRS	1 ea.
Relay Plug Board (A62-650)	GRS	4 ea.
Voltage Test Post	GRS	4 ea.
Misc. (Tags, Term., Eyes, & Etc.)		1 lt.
SIGNAL MATERIAL		
DESCRIPTION	SUPPLIER	QUANTITY
Flasher/Gate Foundation	Progress Rail	2 ea.
Junction Box Base (5" Gate Mast)	Progress Rail	2 ea.
Aluminum Mast 5" x 16" w/o pinnacle	Progress Rail	2 ea.
Pinnacle 5"	Progress Rail	1 ea.
Gate Mech Assy., Model S-40 w/counterweight kit, cast adapter, & conversion brkt.	Safetran	2 ea.
Gate Arm Assy. w/fiberglass gate arm, 3 ea. LED gate lights, and gate light wiring assy. (2 - 22' Arms)	WCH	2 ea.
12" 2-Way LED Flashlight Assy. (5" Gate Mast Mtd.)	Progress Rail	2 ea.
Bell	WCH	1 ea.
Sign, RR Crossing, Hi-Intensity	GETS	2 ea.
Signal Locks	Safetran	2 ea.
Misc. Material	NA	1 lt.
FIELD MATERIAL		
DESCRIPTION	SUPPLIER	QUANTITY
5 Cond. #6 Cable (Signal)	Okonite	450 ft.
7 Cond. #14 Cable (Signal)	Okonite	450 ft.
3 Cond. #6 UG Cable (Power)	Okonite	100 ft.
2 Cond. #6 Twist Pair UG Cable (Track)	Okonite	450 ft.
Track Kit, #6 Trk. Wire	DJR	2 ea.
4" Sched. 80 Conduit (under Tracks)	Carlson	10 ft.
4" Galvanized Conduit (under Road)	Galvanized	50 ft.
Dress Stone, Seed & Mulch	N/A	1 lt.
Reuse Existing Power Service 110V 60AMP Min. per RR Standards		
AAR/DOT Stencil for House & AAR/DOT Tags for Masts	Shannon & Baum	2 ea.
Pavement Marking & Advance Warning Signs (W10-1)	BY OTHERS	
Misc. Field Material		1 lt.

ENGINEER'S ESTIMATE & MATERIAL LIST (Cont.)
SOUTH CENTRAL FLORIDA EXPRESS
S. W. AVENUE "E"
DOT # 272 313P, M.P. 062.16
BELLE GLADE, PALM BEACH COUNTY, FL
8/27/2010

Page 2 of 2

ESTIMATE SUMMARY

SITE SURVEY, ENGINEERING & PLANS		\$	3,500.00
MATERIAL (FOB JOB SITE)			
	Control Material	\$	9,520.00
	Signal Material	\$	37,850.00
	Field Material	\$	<u>11,760.00</u>
TOTAL MATERIAL		\$	59,130.00
SHIPPING		\$	2,957.00
FACTORY WIRING OF EQUIPMENT HOUSE		\$	4,000.00
INSTALLATION - LABOR		\$	18,525.00
INSTALLATION - EQUIPMENT		\$	4,280.00
TEST & PLACE "IN SERVICE"		\$	1,500.00
TRAVEL, LIVING, & MISCELLANEOUS EXPENSE		\$	<u>3,500.00</u>
PROJECT SUBTOTAL COST =		\$	97,392.00
RAILROAD LABOR AND MISC. EXPENSE =		\$	<u>5,000.00</u>
TOTAL PROJECT COST =		\$	102,392.00

- PRICE VALID FOR 30 DAYS FROM DATE OF QUOTE
- PLUS SALES TAX, IF APPLICABLE, AND POWER COMPANY LINE DROP CHARGE, IF ANY

Crossing No:	272313P	Roadway:	SW AVE "E"	County:	Palm Beach	City:	Belle Glade
Rank 2010:	1932	SR No.:		RR Company:	SCXF	Date:	5/21/10
Index 2010:	72.99	US No.:		Division Name:		RR Rep:	Sam Mallo
Rank 2009:	831	Latitude:	26.6824167	Subdivision Name:			
Index 2009:	66.31	Longitude:	80.68435	Branch Name:	K	Crossing Stats Year:	2010
Rank 2008:	865			RR Milepost:	62.16		
Index 2008:	66.23			Recommend Warning:	FL&G		
Purpose:							

Roadway Speed:	25	<input type="checkbox"/>		Min Train Speed:	5	<input type="checkbox"/>	
Crossing Angle:	60-90 deg	<input type="checkbox"/>		Max Train Speed:	45	<input type="checkbox"/>	
Traffic Count/AADT:		<input type="checkbox"/>		Day Thru / Switch:	1 /	<input type="checkbox"/>	
Truck %:		<input type="checkbox"/>		Night Thru / Switch:	29 /	<input type="checkbox"/>	
School Buses:	0	<input type="checkbox"/>		Passenger Train Count:		<input type="checkbox"/>	
Traffic Date:		<input type="checkbox"/>		Commuter Train Count:		<input type="checkbox"/>	
Thru Lanes:	2	<input type="checkbox"/>		Train Count Date:	1/18/2000	<input type="checkbox"/>	
Aux Lanes:	0	<input type="checkbox"/>		Mainline Tracks:	1	<input type="checkbox"/>	
Traf Sgnl Preemp: Not Interconnect		<input type="checkbox"/>		Other Line Tracks:	0	<input type="checkbox"/>	
Train Sgnl in Proximty to Xing?		<input type="checkbox"/>		Train Detection:	Other	<input type="checkbox"/>	
ENS (Y/N):	N	<input type="checkbox"/>		Flashing on Cant not over Traffic:	0	<input type="checkbox"/>	
Crossbucks on Mast:	2	<input checked="" type="checkbox"/>		Flashing on Cant over Traffic:	0	<input type="checkbox"/>	
Crossbucks on Cantilever:	0	<input type="checkbox"/>		Flashing Lights on Mast:	2	<input checked="" type="checkbox"/>	
Stop Sign:	0	<input type="checkbox"/>		Gate Count:	2	<input checked="" type="checkbox"/>	
Yield Signs (Y/N):	N	<input type="checkbox"/>		4 Quad Gates (Y/N):	N	<input type="checkbox"/>	
Other Sign:		<input type="checkbox"/>		Ped Gates(None/FLG):		<input type="checkbox"/>	
# Other Signs:		<input type="checkbox"/>		LED Count:	0	<input type="checkbox"/>	
Advanced Warning (Y/N):	N	<input type="checkbox"/>		8" Count:	0	<input type="checkbox"/>	
Side St. Adv Warning (Y/N):	N	<input type="checkbox"/>		12" Count:	8	<input type="checkbox"/>	
Hump Sign (Y/N):	Unknown	<input type="checkbox"/>		Signal Mod Date:		<input type="checkbox"/>	
Pvmnt Marks:	None	<input type="checkbox"/>		Signal Maint Agency:	New Field	<input type="checkbox"/>	
Bell Count:	1	<input type="checkbox"/>		Surface Maint Agency:	City	<input type="checkbox"/>	
Surface Mod Date:		<input type="checkbox"/>		Sidewalk Thru Xing (Y/N):	N/A	<input type="checkbox"/>	
Surface Type:	Timber	<input type="checkbox"/>		Sidewalk Present (Y/N):	N	<input type="checkbox"/>	
Surface Condition:	Poor	<input type="checkbox"/>		Illuminated (Y/N):	Y	<input type="checkbox"/>	
Approach:	Extensive	<input type="checkbox"/>		Distance mast to curb (4'9") or (2') sw		<input type="checkbox"/>	
Vehicle Reaction:	Appreciable	<input type="checkbox"/>		Distance mast to travelway (12'3")		<input type="checkbox"/>	
Driver Reaction:	Most Drivers	<input type="checkbox"/>		If < 45mph, mast to travel (10')		<input type="checkbox"/>	
Team Recommendations:				Lane width > 23' = cantilever		<input type="checkbox"/>	
<p>2 Gates / Side Light NB.</p> <p>NB: Advance side Warning Sign.</p>				Mast to RR (15') or (12' exception)		<input type="checkbox"/>	
				Gate Tip to median (4')		<input type="checkbox"/>	
						<input type="checkbox"/>	

Conflicts:

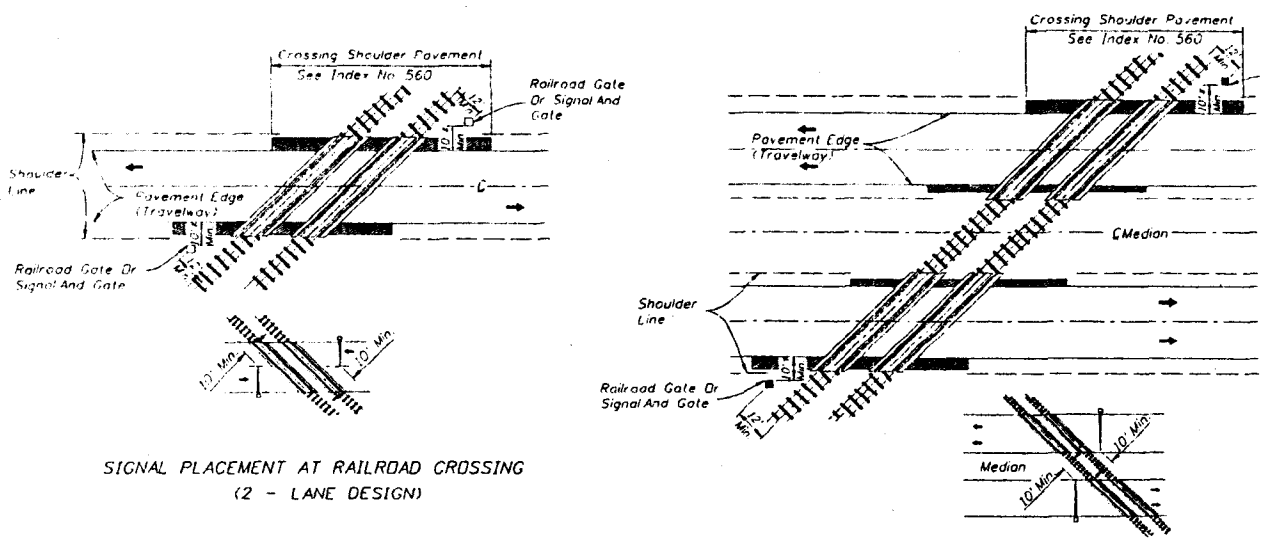

SIGNAL PLACEMENT AT RAILROAD CROSSING
(2 - LANE DESIGN)

SIGNAL PLACEMENT AT RAILROAD CROSSING
(4 - LANE DESIGN)

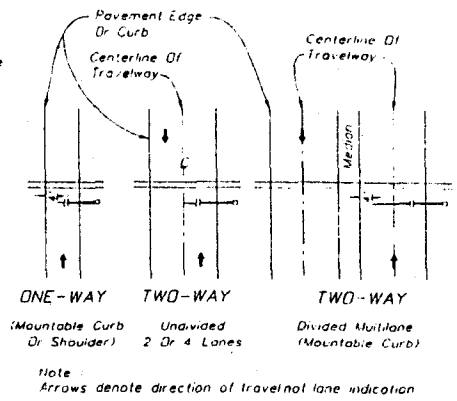
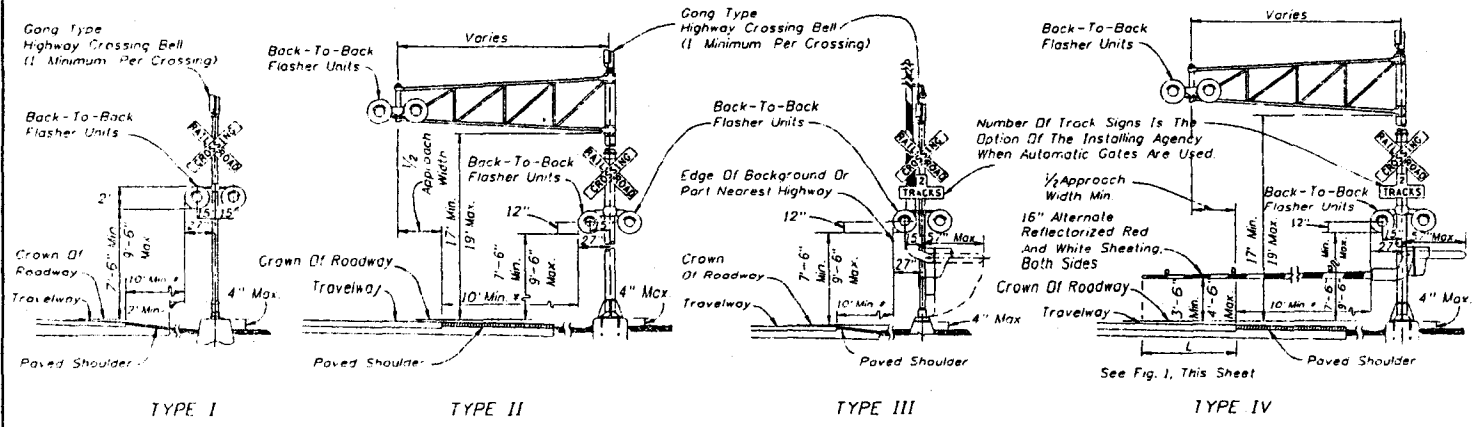

FIGURE 1
Gate Length Requirements
See Note 5 Sheet 3



TYPE I TYPE II TYPE III TYPE IV

- General Notes
- No guardrail is proposed for signals, however some form of impact attenuation device may be specified for certain locations.
 - Advance flasher to be installed when and if called for in plans or specifications.
 - Top of foundation shall be no higher than 4" above finished shoulder grade.
 - Type of traffic control device
 - Flashing signals
 - Flashing signals with cantilever
 - Flashing signals with gate
 - Flashing signals with cantilever & gate
 - Gate
 - Class of traffic control devices
 - Flashing signals - one track
 - Flashing signals - multiple tracks
 - Flashing signals and gates - one track
 - Flashing signals and gates - multiple tracks

* When 10' is deemed impractical the control device can be located as close as 2' from the edge of a paved shoulder but not less than 6' from the edge of the near traffic lane.

Note:
Two separate foundations may be required (one for signals, one for gate), depending on type of equipment used

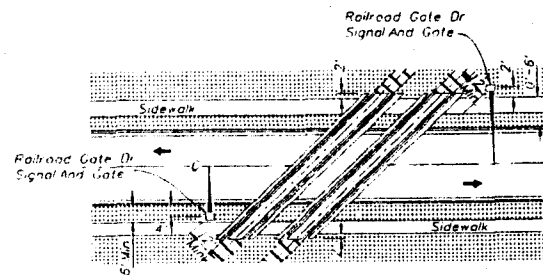

ACUTE ANGLE (AND RIGHT ANGLE)

SIGNAL PLACEMENT AT RAILROAD CROSSING
(2 LANES, CURB & GUTTER)

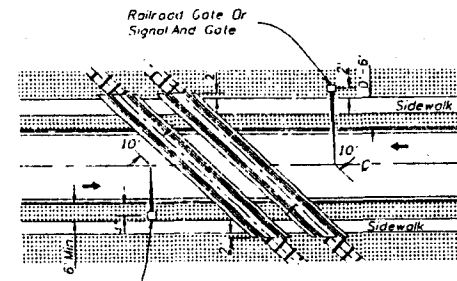

OBTUSE ANGLE

SIGNAL PLACEMENT AT RAILROAD CROSSING
(2 LANES, CURB & GUTTER)

GENERAL NOTES

1. The location of flashing signals and stop lines shall be established based on future (or present) installation of gate with appropriate track clearances.
2. Where plans call for railroad traffic control devices to be installed in curbed medians, the minimum median width shall be 12'-6".
3. Location of railroad traffic control device is based on the distance available between face of curb & sidewalk:
0' to 5' - Locate device outside sidewalk.
Over 5' - Locate device between face of curb and sidewalk.
4. Stop line to be perpendicular to edge of roadway, approx. 15' from nearest rail or 8' from and parallel to gate when present.

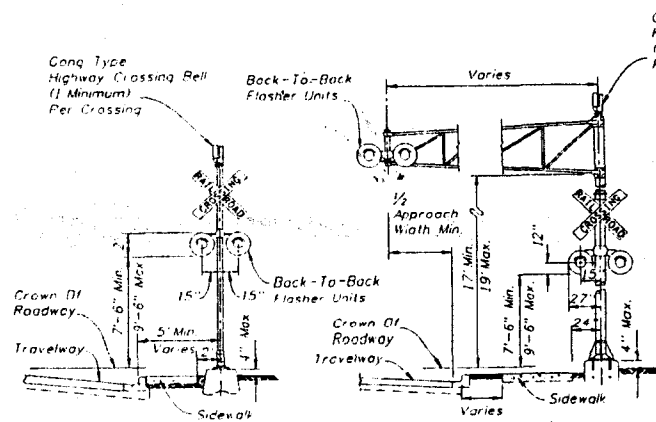

TYPE I

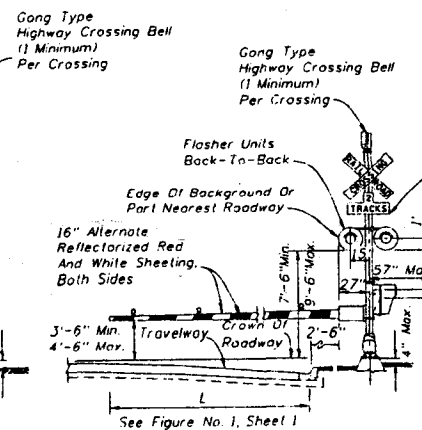

TYPE III

As A Minimum, Position One Flasher Unit Over Lane Separation Lines (More Than One Flasher Unit If There Are More Than 2 Approach Lanes).

Number Of Tracks Signs Is The Option Of The Installing Agency When Automatic Gates Are Used.

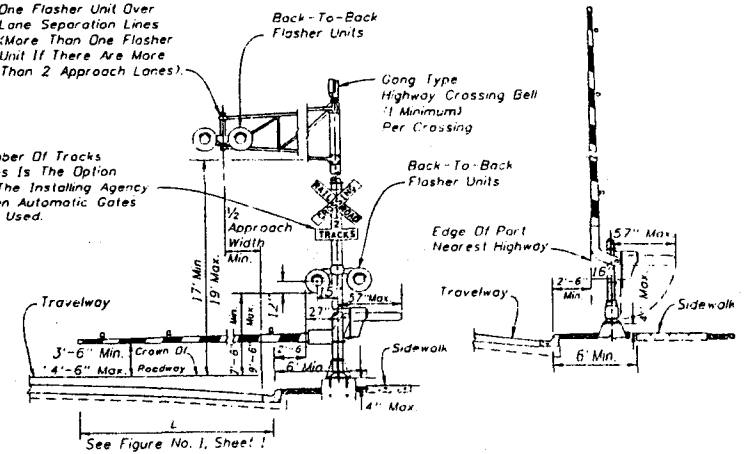

TYPE IV

TYPE V



2008 FDOT Design Standards

RAILROAD GRADE CROSSING
TRAFFIC CONTROL DEVICES

Last Revision	Sheet No.
07/01/00	2 of 4
Index No.	
17882	

RAILROAD CROSSING AT
TWO (2)-LANE ROADWAY

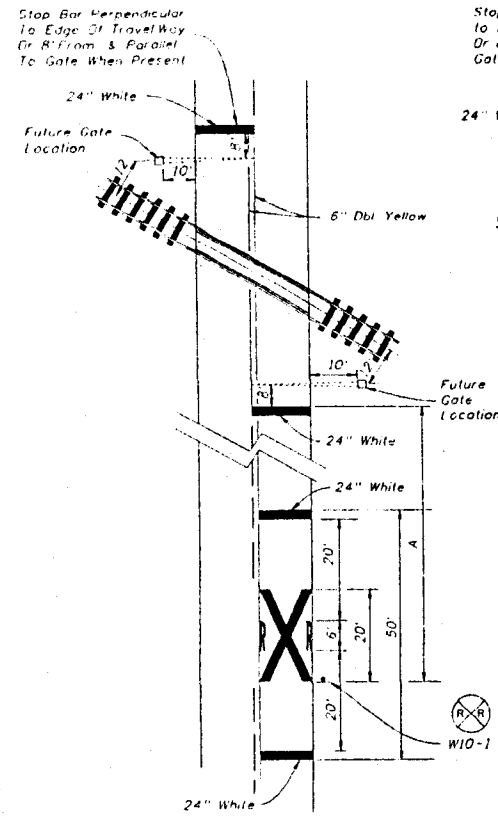

RAILROAD CROSSING AT
MULTILANE ROADWAY

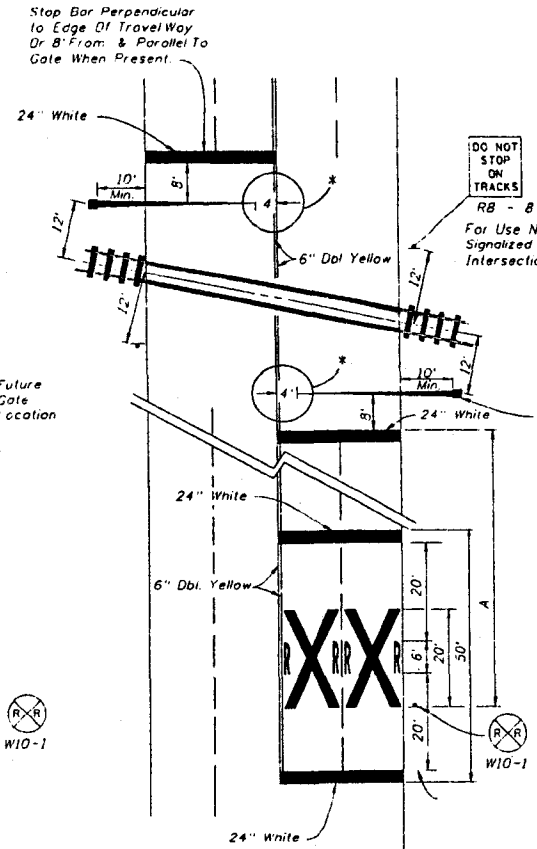

RELATIVE LOCATION OF CROSSING TRAFFIC
CONTROL DEVICES

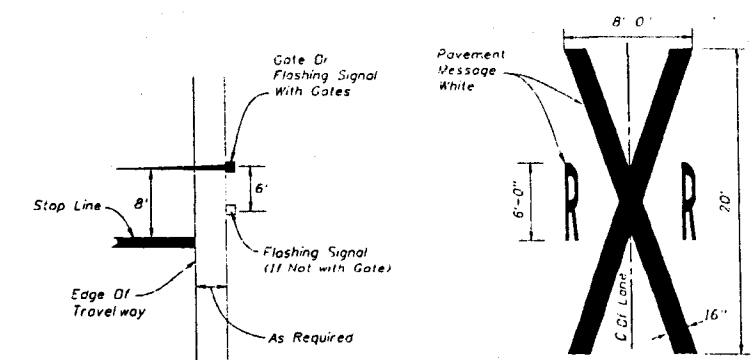

NOTES:

- When computing pavement message, quantities do not include traverse lines.
- Placement of sign W10-1 in a residential or business district where low speeds are prevalent, the W10-1 sign may be placed a minimum distance of 100' from the crossing. Where street intersections occur between the RR pavement message and the tracks an additional W10-1 sign and additional pavement message should be used.
- A portion of the pavement markings symbol should be directly opposite the W10-1 sign.
- Recommended location for FTP-61-06 or FTP-62-06 signs, 100' urban and 300' rural. See Index 17355 for sign details.
- Gate Length Requirements:
For two-way undivided sections:
The gate should extend to within 1' of the center line. On multiple approaches the maximum gate length may not reach to within 1' of the center line. For those cases, the distance from the gate to the center line shall be a maximum of 4'.
For one-way or divided sections:
The gate shall be of sufficient length such that the distance from the gate lip to the inside edge of pavement is a maximum of 4'.

SPEED MPH	" A " IN FT.
60	400
55	325
50	250
45	175
40	125
35	100
URBAN	85 MIN

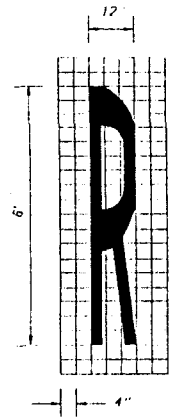

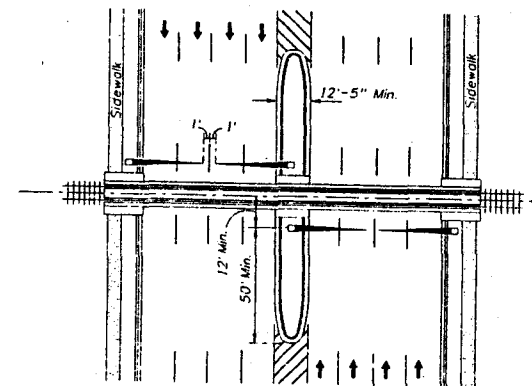
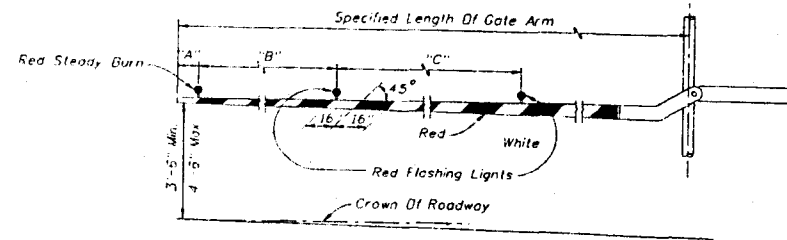

PLAN

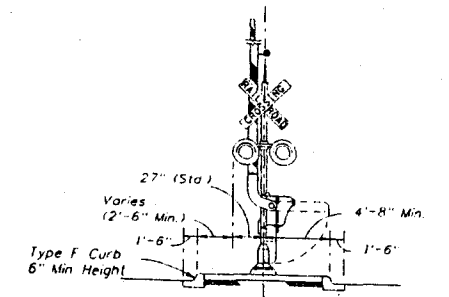

MEDIAN SECTION AT SIGNAL GATES

NOTE:
For additional information see the "Manual On Uniform Traffic Control Devices", Part B, The "Traffic Control Handbook", Part VIII, and AASHTO "A Policy On Geometric Design Of Streets And Highways".

RAILROAD GATE ARM LIGHT SPACING

Specified Length Of Gate Arm	Dimension "A"	Dimension "B"	Dimension "C"
14 Ft	6"	36"	5'
15 Ft	18"	36"	5'
16-17 Ft	24"	36"	5'
18-19 Ft	29"	41"	5'
20-23 Ft	28"	4'	5'
24-26 Ft	29"	5'	5'
29-31 Ft	36"	6'	6'
32-34 Ft	36"	7'	7'
35-37 Ft	36"	9'	9'
38 And Over	35"	10'	10'

MEDIAN SIGNAL GATES FOR
MULTILANE UNDIVIDED URBAN SECTIONS

(THREE OR MORE DRIVING LANES IN ONE DIRECTION, 45 MPH OR LESS)



2008 FDOT Design Standards

RAILROAD GRADE CROSSING
TRAFFIC CONTROL DEVICES

Last Revision	Sheet No.
07/01/07	4 of 4
Index No.	
17882	

AFFIDAVIT OF CORPORATE SECRETARY

STATE OF FLORIDA
COUNTY OF HENDRY

BEFORE ME, the undersigned authority, personally appeared EDWARD ALMEIDA, as Corporate Secretary ("Affiant") of SOUTH CENTRAL FLORIDA EXPRESS, INC., a Florida Corporation ("SCFE"), who being by me first duly sworn, on oath, deposes and says, to the best of Affiant's knowledge and belief that:

1. Affiant is a duly elected and incumbent Corporate Secretary of SCFE.
2. Affiant, as Corporate Secretary, is responsible for maintaining the corporate books and records of SCFE.
3. The duly elected, appointed, qualified and acting officers of SCFE include the following:
Kenneth W. McDuffie, President;
Edward Almeida, Secretary; and
Gerard A. Bernard, Assistant Secretary & Treasurer.
4. The officers identified in Paragraph 3 hereinabove are authorized by SCFE to execute and deliver on behalf of SCFE any and all documents necessary or appropriate, and to take any and all actions necessary and required on behalf of SCFE in connection with its railroad crossing project in Palm Beach County, Florida.
5. The foregoing authority does not violate any provision of the Articles of Incorporation, as amended, or Bylaws of SCFE.
6. Affiant is familiar with the nature of an oath and with the penalties provided by the laws of the State aforesaid for falsely swearing to statements made in an instrument of this nature, and Affiant further certifies that Affiant has read the full facts of this Affidavit and understands its contents.
7. Affiant has the authority to execute this Affidavit on behalf, and with the full binding authority, of SCFE.

[the remainder of this page has intentionally been left blank]

FURTHER AFFIANT SAYETH NAUGHT.

AFFIANT



EDWARD ALMEIDA,
Corporate Secretary

STATE OF FLORIDA
COUNTY OF HENDRY

THE FOREGOING INSTRUMENT was sworn to and subscribed before me this 12th day of January 2012, by Edward Almeida as Corporate Secretary of South Central Florida Express, Inc., a Florida corporation, who is personally known to me, who acknowledged that he executed such instrument on behalf of, and with the full and binding authority of said corporation, and who did take an oath.

(seal)



Kay Brasecker
Notary Public, State of Florida at Large
Kay Brasecker
Print Notary Public's Name

My Commission Expires: June 18, 2013
My Commission Number: DD 868188