

II. FISCAL IMPACT ANALYSIS

A. Five Year Summary of Fiscal Impact:

Fiscal Years	2014	2015	2016	2017	2018
Capital Expenditures	\$ <u>-0-</u>	<u>-0-</u>	<u>-0-</u>	<u>-0-</u>	<u>-0-</u>
Operating Costs	<u>-0-</u>	<u>-0-</u>	<u>-0-</u>	<u>-0-</u>	<u>-0-</u>
External Revenues	<u>-0-</u>	<u>-0-</u>	<u>-0-</u>	<u>-0-</u>	<u>-0-</u>
Program Income (County)	<u>-0-</u>	<u>-0-</u>	<u>-0-</u>	<u>-0-</u>	<u>-0-</u>
In-Kind Match (County)	<u>-0-</u>	<u>-0-</u>	<u>-0-</u>	<u>-0-</u>	<u>-0-</u>
NET FISCAL IMPACT	<u>* -0-</u>	<u>-0-</u>	<u>-0-</u>	<u>-0-</u>	<u>-0-</u>
# ADDITIONAL FTE					
POSITIONS (Cumulative)					

Is Item Included in Current Budget? Yes X No

Budget Account No:

Fund 1201 Dept 360 Unit 2270 Object 4607

Recommended Sources of Funds/Summary of Fiscal Impact:

County Transportation Trust Fund
 Railroad Crossing Maintenance

*No additional fiscal impact.

C. Departmental Fiscal Review:

Alicia Kovalainen

III. REVIEW COMMENTS

A. OFMB Fiscal and/or Contract Dev. and Control Comments:

Maria Hubert
 OFMB
 2/13 2/14

Dr. J. Garcia 3/5/14
 Contract Dev. and Control
 3-5-14

B. Approved as to Form and Legal Sufficiency:

Mark R. [Signature] 3/6/14
 Assistant County Attorney

C. Other Department Review:

 Department Director

This summary is not to be used as a basis for payment.

CENTER STREET @ FEC RAILROAD CROSSING

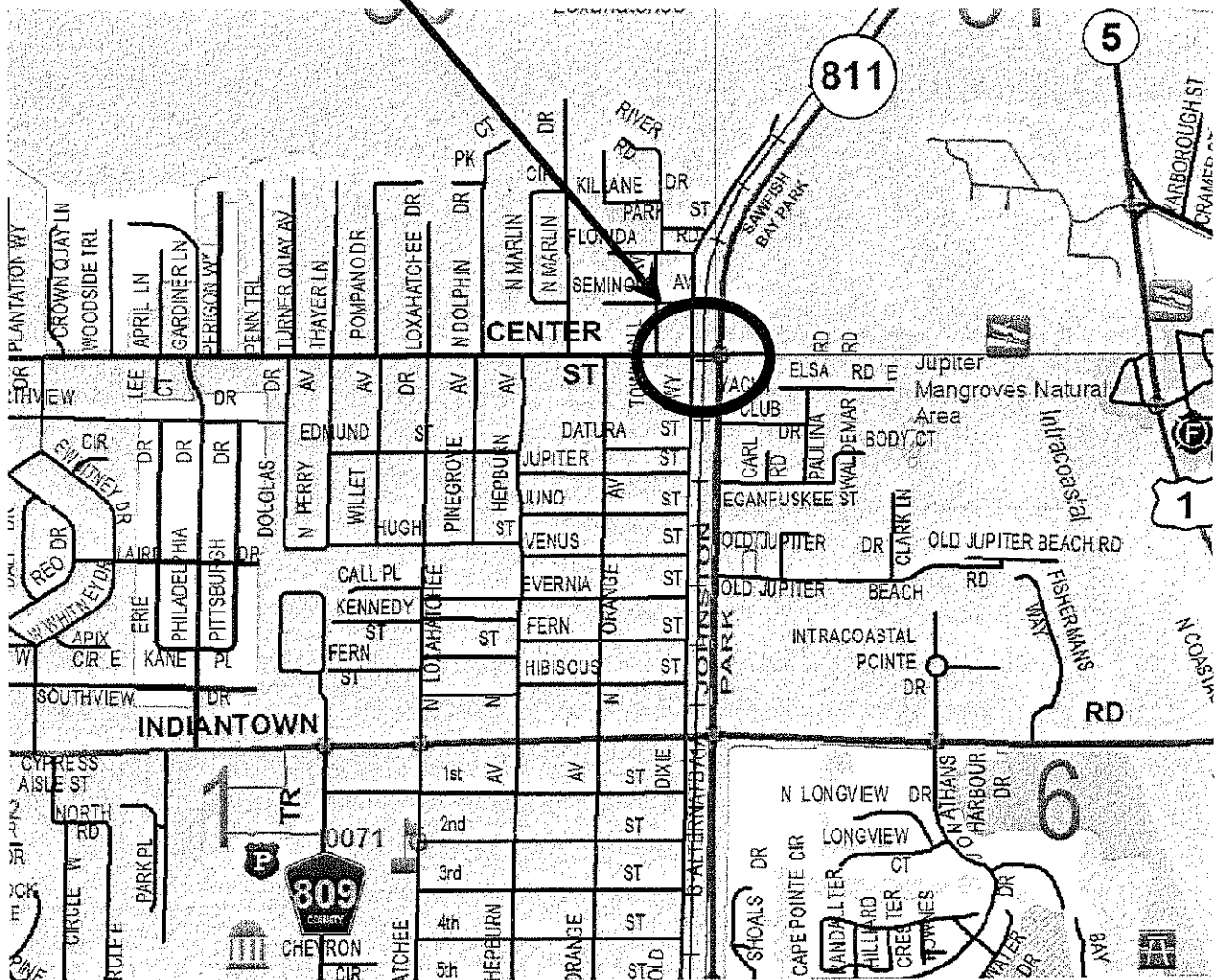

LOCATION MAP

RESOLUTION NO. R-2014_____

**RESOLUTION OF THE BOARD OF COUNTY
COMMISSIONERS OF PALM BEACH COUNTY, FLORIDA
AUTHORIZING EXECUTION OF A RAILROAD
AGREEMENT WITH FLORIDA EAST COAST RAILWAY
L.L.C. AND FLORIDA DEPARTMENT OF
TRANSPORTATION FOR SAFETY IMPROVEMENTS AT
THE CENTER STREET RAILROAD CROSSING**

WHEREAS, the Florida Department of Transportation (FDOT) is constructing, reconstructing or otherwise changing a portion of the public road system on Center Street which requires the installation of railroad grade crossing traffic control devices for the railroad grade crossing over Center Street; and

WHEREAS, FDOT will fund safety improvements to Center Street at the Florida East Coast Railway L.L.C. (FEC) crossing designated as Financial Project Number 43333015701 at Crossing Number 272376-U in Palm Beach County, Florida and

WHEREAS, FEC will construct the safety improvements; and

WHEREAS, Palm Beach County will continue to fund 50% of the annual maintenance fees which is currently \$1,701.

**NOW, THEREFORE, BE IT RESOLVED BY THE BOARD OF COUNTY
COMMISSIONERS OF PALM BEACH COUNTY FLORIDA:**

That Palm Beach County enter into a railroad agreement with FDOT and FEC for the funding, construction and maintenance of the safety improvements, and

That the Mayor of the Board of County Commissioners be authorized to enter into such agreement with FDOT and FEC, as herein described; and

That this RESOLUTION shall take effect immediately upon adoption.

RESOLUTION NO. R-2014-
March 11, 2014

The foregoing Resolution was offered by Commissioner _____ who moved its adoption. The motion was seconded by Commissioner _____, and upon being put to a vote, the vote was as follows:

- Mayor: Priscilla A. Taylor, District 7 _____
- Vice Mayor: Paulette Burdick, District 2 _____
- District 1: Hal R. Valeche _____
- District 3: Shelley Vana _____
- District 4: Steven L. Abrams _____
- District 5: Mary Lou Berger _____
- District 6: Jess R. Santamaria _____

The Mayor thereupon declared the Resolution duly passed and adopted this ____ day of _____, 20__.

PALM BEACH COUNTY, FLORIDA, BY ITS
BOARD OF COUNTY COMMISSIONERS

ATTEST:

SHARON R. BOCK
CLERK & COMPTROLLER

BY: _____
Deputy Clerk

S E A L

APPROVED AS TO FORM
AND LEGAL SUFFICIENCY

By: _____
(County Attorney)

STATE OF FLORIDA DEPARTMENT OF TRANSPORTATION
RAILROAD REIMBURSEMENT AGREEMENT
GRADE CROSSING TRAFFIC CONTROL DEVICES - COUNTY

725-090-27
 RAIL
 OGC - 04/12

FINANCIAL PROJECT NO.	ROAD NAME OR NUMBER	COUNTY NAME	PARCEL & R/W NUMBER	FAP NUMBER
43333015701	CENTER STREET	PALM BEACH	1(93090-SIGW)	00S4-051 J

THIS AGREEMENT, made and entered into this _____ day of _____, _____, by and between the STATE OF FLORIDA DEPARTMENT OF TRANSPORTATION, hereinafter called the DEPARTMENT, and FLORIDA EAST COAST RAILWAY L.L.C., a corporation organized and existing under the laws of FLORIDA, with its principal place of business in the City of JACKSONVILLE, County of DUVAL, State of FLORIDA, hereinafter called the COMPANY; and PALM BEACH County, a political subdivision of the State of Florida, acting by and through its Board of County Commissioners, hereinafter called the COUNTY.

WITNESSETH:

WHEREAS, the DEPARTMENT is constructing, reconstructing or otherwise changing a portion of the Public Road System, designated by the Financial Project ID 43333015701, on CENTER STREET, which crosses at grade the right of way and tracks of the COMPANY'S Milepost 283 + 510', FDOT/AAR Crossing Number 272376-U, at or near TOWN OF JUPITER, as shown on DEPARTMENT'S Plan Sheet No. LOCATION MAP, attached hereto as a part hereof; and

NOW, THEREFORE, in consideration of the mutual undertakings as herein set forth, the parties hereto agree as follows:

1. The COMPANY shall furnish the necessary materials and install Automatic Grade Crossing Signals Type IV Class III and/or other traffic control devices at said location on an actual cost basis and in accordance with (1) the attached detailed statement of the work, plans, and specifications; and (2) the DEPARTMENT'S Plans and Standard Index Number 17882 attached hereto and made a part hereof.
2. After installation of said signals is completed, fifty (50%) percent of the expense thereof in maintaining the same shall be borne by the COUNTY and fifty (50%) percent shall be borne by the COMPANY, as enumerated by the Schedule of Annual Cost of Automatic Highway Grade Crossing Devices attached hereto and by this reference made a part hereof and subject to future revision.
3. After said signals have been installed and found to be in satisfactory working order by the parties hereto, the same shall be immediately put into service, operated and maintained by the COMPANY so long as said COMPANY or its successors or assigns shall operate the said signals at said grade crossing; or until it is agreed between the parties hereto that the signals are no longer necessary or until the said crossing is abandoned; or legal requirements occur which shall cease operation of signals thereat.

The COMPANY agrees that any future relocation or adjustment of said signals shall be performed by the COMPANY, but at the expense of the party initiating such relocation. Upon relocation the maintenance responsibilities shall be in accordance with the provisions of this agreement. It is further agreed that the cost of maintaining any additional or replacement signal equipment at the same location will be shared as provided under Paragraph 2. above.

4. Unless otherwise agreed upon herein, the COUNTY agrees to ensure that at the crossing the advance warning signs and railroad crossing pavement markings will conform to the U.S. Department of Transportation Manual on Uniform Traffic Control Devices within 30 days of notification that the railroad signal improvements have been completed and that such signs and pavement markings will be continually maintained at an acceptable level.

5. The COMPANY hereby agrees to install and/or adjust the necessary parts of its facilities along said road in accordance with the provisions set forth in the:

- (a) DEPARTMENT Procedure No. 725-080-002 Appendix D.4, and Rule 14.57.011 "Public Railroad-Highway Grade Crossing Costs", Florida Administrative Code.
- (b) Federal Highway Administration Federal-Aid Policy Guide, 23 C.F.R. Subchapter G, Part 646, Subpart B, and 23 C.F.R., Subchapter B, Part 140, Subpart I,

and any supplements thereto or revisions thereof, which, by reference hereto, are made a part hereof. The COMPANY further agrees to do all of such work, with its own forces or by a contractor paid under a contract let by the COMPANY, all under the supervision and approval of the DEPARTMENT and the Federal Highway Administration, when applicable.

6. The DEPARTMENT hereby agrees to reimburse the COMPANY for all costs incurred by it in the installation and/or adjustment of said facilities, in accordance with the provisions of Procedure No. 725-080-002 Appendix D-4 "Billing Requirements," and any supplements thereto or revisions thereof. It is understood and agreed by and between the parties hereto that preliminary engineering costs not incorporated within this agreement shall not be subject to payment by the DEPARTMENT.

7. Attached hereto, and by this reference made a part hereof, are plans and specifications of the work to be performed by the COMPANY pursuant to the terms hereof, and an itemized estimate of the cost thereof in the amount of \$ 67,680.00 . All work performed by the COMPANY pursuant hereto, shall be performed according to these plans and specifications as approved by the DEPARTMENT and the Federal Highway Administration if federal aid participating; and all subsequent plan changes shall likewise be approved by the DEPARTMENT and the Federal Highway Administration, when applicable.

8. All labor, services, materials, and equipment furnished by the COMPANY in carrying out the work to be performed hereunder shall be billed by the COMPANY direct to the DEPARTMENT. Separate records as to the costs of

contract bid items and force account items performed for the COMPANY shall also be furnished by the COMPANY to the DEPARTMENT.

9. The COMPANY has determined that the method to be used in developing the relocation or installation cost shall be as specified for the method checked and described hereafter:

- (a) Actual and related indirect costs accumulated in accordance with a work order accounting procedure prescribed by the applicable Federal or State regulatory body.
- (b) Actual and related indirect costs accumulated in accordance with an established accounting procedure developed by the COMPANY and approved by the DEPARTMENT.
- (c) An agreed lump sum \$ _____, as supported by a detail analysis of estimated cost attached hereto. (NOTE: This method is not applicable where the estimated cost of the proposed adjustment exceeds \$100,000.)

10. The installation and/or adjustment of the COMPANY'S facility as planned will will not involve additional work over and above the minimum reimbursable requirements of the DEPARTMENT. (If upgrading and/or nonreimbursable work is involved at the option of the COMPANY, then credit against the cost of the project is required and will be governed by the method checked and described hereafter):

- (a) _____ % will be applied to the final billing of work actually accomplished to determine required credit for (betterment) and/or (expired service life) and/or (nonreimbursable segments).
- (b) All work involving nonreimbursable segments will be performed by special COMPANY work or job order number apart and separate from the reimbursable portion of the work; such work or job order number to be _____. The COMPANY further agrees to clearly identify such additional work areas in the COMPANY'S plans and estimates for the total work covered by this Agreement.
- (c) \$ _____ credited for betterment expired service life
 nonreimbursable segments in accord with Article 9.(c) hereinabove.

11. It is specifically agreed by and between the DEPARTMENT and the COMPANY that the DEPARTMENT shall receive fair and adequate credit for any salvage which shall accrue to the COMPANY as a result of the above installation and/or adjustment work.

12. It is further agreed that the cost of all improvements made during this adjustment work shall be borne by the COMPANY, subject only to the DEPARTMENT bearing such portion of this cost as represents the cost of adjustment of previously existing facility, less salvage credit as set forth in the immediately preceding paragraph.

13. Upon completion of the work the COMPANY shall, within one hundred eighty (180) days, furnish the DEPARTMENT with two (2) copies of its final and complete billing of all costs incurred in connection with the work performed hereunder, such statement to follow as closely as possible the order of the items contained in the estimate attached hereto. The totals for labor, overhead, travel expense, transportation, equipment, material and supplies, handling costs and other services shall be shown in such a manner as will permit ready comparison with the approved plans and estimates. Materials shall be itemized where they represent major components of cost in the relocation following the pattern set out in the approved estimate as closely as is possible. Salvage credits from recovered and replaced permanent and recovered temporary materials shall be reported in said bills in relative position with the charge for the replacement or the original charge for temporary use.

The final billing shall show the description and site of the Project; the date on which the first work was performed, or, if preliminary engineering or right-of-way items are involved, the date on which the earliest item of billed expense was incurred; the date on which the last work was performed or the last item of billed expense was incurred; and the location where the records and accounts billed can be audited. Adequate reference shall be made in the billing to the COMPANY'S records, accounts and other relevant documents. All cost records and accounts shall be subject to audit by a representative of the DEPARTMENT. Upon receipt of invoices, prepared in accordance with the provisions of the above indicated Reimbursement Policy, the DEPARTMENT agrees to reimburse the COMPANY in the amount of such actual costs as approved by the DEPARTMENT'S auditor.

14. Payment shall be made only after receipt and approval of goods and services unless advance payments are authorized by the DEPARTMENT'S Comptroller under Section 334.044(29), F.S., or by the Department of Financial Services under Section 215.422(14), Florida Statutes (F.S.).

15. In accordance with Section 287.058, Florida Statutes, the following provisions are in this Agreement: If this Contract involves units of deliverables, then such units must be received and accepted in writing by the Contract Manager prior to payments. Bills for fees or other compensation for services or expenses shall be submitted in detail sufficient for a proper preaudit and postaudit thereof.

16. Bills for travel expenses specifically authorized in this agreement shall be submitted and paid in accordance with DEPARTMENT Rule 14-57.011 "Public Railroad-Highway Grade Crossing Costs" and the Federal Highway Administration Federal-Aid Policy Guide, Subchapter B, Part 140, Subpart I "Reimbursement for Railroad Work."

17. In accordance with Section 215.422, Florida Statutes, the following provisions are in this Agreement: Contractors providing goods and services to the Department should be aware of the following time frames. Upon receipt, the Department has five (5) working days to inspect and approve the goods and services, unless the Agreement specifies otherwise. The Department has 20 days to deliver a request for payment (voucher) to the Department of Financial Services. The 20 days are measured from the latter of the date the invoice is received or the goods or services are received, inspected and approved.

If a payment is not available within 40 days, a separate interest penalty at a rate as established pursuant to Section 215.422(3)(b), Florida Statutes, will be due and payable, in addition to the invoice amount, to the Contractor. Interest penalties of less than one (1) dollar will not be enforced unless the Contractor requests payment. Invoices which have to be returned to a Contractor because of Contractor preparation errors will result in a delay in the payment. The invoice payment requirements do not start until a properly completed invoice is provided to the Department.

A Vendor Ombudsman has been established within the Department of Financial Services. The duties of this individual include acting as an advocate for contractors/vendors who may be experiencing problems in obtaining timely payment(s) from a state agency. The Vendor Ombudsman may be contacted at (850) 413-5516 or by calling the Division of Consumer Services at 1-877-693-5236.

18. Records of costs incurred under terms of this Agreement shall be maintained and made available upon request to the Department at all times during the period of this Agreement and for five years after final payment is made. Copies of these documents and records shall be furnished to the Department upon request. Records of costs incurred includes the Contractor's general accounting records and the project records, together with supporting documents and records, of the Contractor and all subcontractors performing work on the project, and all other records of the Contractor and subcontractors considered necessary by the Department for a proper audit of costs.

19. In the event this contract is for services in excess of TWENTY FIVE THOUSAND DOLLARS (\$25,000.00) and a term for a period of more than one year, the provisions of Section 339.135(6)(a), Florida Statutes, are hereby incorporated:

The Department, during any fiscal year, shall not expend money, incur any liability, or enter into any contract which, by its terms, involves the expenditure of money in excess of the amounts budgeted as available for expenditure during such fiscal year. Any contract, verbal or written, made in violation of this subsection is null and void, and no money may be paid on such contract. The Department shall require a statement from the Comptroller of the Department that such funds are available prior to entering into any such contract or other binding commitment of funds. Nothing herein contained shall prevent the making of contracts for periods exceeding one year, but any contract so made shall be executory only for the value of the services to be rendered or agreed to be paid for in succeeding fiscal years; and this paragraph shall be incorporated

verbatim in all contracts of the Department which are for an amount in excess of TWENTY FIVE THOUSAND DOLLARS (\$25,000.00) and which have a term for a period of more than one year.

20. In accordance with Section 287.133 (2)(a), Florida Statutes, the following provisions are included in this Agreement:

A person or affiliate who has been placed on the convicted vendor list following a conviction for a public entity crime may not submit a bid, proposal, or reply on a contract to provide any goods or services to a public entity; may not submit a bid, proposal, or reply on a contract with a public entity for the construction or repair of a public building or public work; may not submit bids, proposals, or replies on leases of real property to a public entity; may not be awarded or perform work as a contractor, supplier, subcontractor, or consultant under a contract with any public entity; and may not transact business with any public entity in excess of the threshold amount provided in s.287.017 for CATEGORY TWO for a period of 36 months following the date of being placed on the convicted vendor list.

21. In accordance with Section 287.134(2)(a), Florida Statutes, the following provisions are included in this Agreement:

An entity or affiliate who has been placed on the discriminatory vendor list may not submit a bid, proposal, or reply on a contract to provide any goods or services to a public entity; may not submit a bid, proposal, or reply on a contract with a public entity for the construction or repair of a public building or public work; may not submit bids, proposals, or replies on leases of real property to a public entity; may not be awarded or perform work as a contractor, supplier, subcontractor, or consultant under a contract with any public entity; and may not transact business with any public entity.

22. In accordance with Section 287.0582, Florida Statutes, the following provision is included in this Agreement:

The Department's obligation to pay under this contract is contingent upon an annual appropriation by the Florida Legislature.

23. ~~The COMPANY covenants and agrees that it will indemnify and hold harmless the DEPARTMENT and all of the DEPARTMENT'S officers, agents, and employees from any claim, loss, damage, cost charge, or expense arising out of any act, action, neglect, omission or delay by the COMPANY during the performance of the contract, whether direct or indirect, and whether to any person or property to which the DEPARTMENT or said parties may be subject, except that neither the COMPANY nor any of its sub-contractors will be liable under this section for damages arising out of injury or damage to persons or property directly caused or resulting from the sole negligence of the DEPARTMENT or any of its officers, agents, or employees.~~

24. COMPANY shall:

1. utilize the U.S. Department of Homeland Security's E-Verify system to verify the employment eligibility of all new employees hired by the COMPANY during the term of the contract; and
2. expressly require any subcontractors performing work or providing services pursuant to the state contract to likewise utilize the U.S. Department of Homeland Security's E-Verify system to verify the employment eligibility of all new employees hired by the subcontractor during the contract term.

whether direct or indirect, and whether to any person or property to which the DEPARTMENT or said parties may be subject, except that neither the COMPANY nor any of its sub-contractors will be liable under this section for damages arising out of injury or damage to persons or property directly caused or resulting from the sole negligence of the DEPARTMENT or any of its officers, agents, or employees.

24. COMPANY shall:

1. utilize the U.S. Department of Homeland Security's E-Verify system to verify the employment eligibility of all new employees hired by the COMPANY during the term of the contract; and
2. expressly require any subcontractors performing work or providing services pursuant to the state contract to likewise utilize the U.S. Department of Homeland Security's E-Verify system to verify the employment eligibility of all new employees-hired by the subcontractor during the contract term.

25. It is understood and agreed by the parties to this Agreement that if any part, term, or provision of this Agreement is held illegal by the courts or in conflict with any law of the State of Florida, the validity of the remaining portions or provisions shall not be affected, and the rights and obligations of the parties shall be construed and enforced as if the Agreement did not contain the particular part, term, or provision held to be invalid.

26. Any questions or matters arising under this Agreement as to validity, construction, enforcement, performance, or otherwise, shall be determined in accordance with the laws of the State of Florida. Venue for any action arising out of or in any way related to this Agreement shall lie exclusively in a state court of appropriate jurisdiction, ~~in Leon County, Florida.~~

27. The parties agree to bear their own attorney's fees and costs with respect to this Agreement.

28. The parties agree that this Agreement is binding on the parties, their heirs-at-law, and their assigns and successors in interest as evidenced by their signatures and lawful executions below.

29. A modification or waiver of any of the provisions of this Agreement shall be effective only if made in writing and executed with the same formality as this Agreement.

30. PARAGRAPH 23 WAS STRICKEN PRIOR TO THE EXECUTION BY ALL PARTIES, AT THE REQUEST OF THE FLORIDA EAST COAST RAILWAY L.L.C.

31. THE PARTIES TO THIS AGREEMENT SHALL HAVE ACCESS TO PUBLIC RECORDS PURSUANT TO CHAPTER 119, FLORIDA STATUTES.

IN WITNESS WHEREOF, the parties hereto have caused these presents to be executed by their duly authorized officers, the day and year first written above.

PALM BEACH COUNTY, a Political
Subdivision of the State of Florida Board of
County Commissioners

By: _____
Chairperson

ATTEST:
SHARON R. BOCK
CLERK & COMPTROLLER

By: _____
Clerk

APPROVED AS TO FORM
AND LEGAL SUFFICIENCY

COUNTY ATTORNEY
(Seal)

APPROVED AS TERMS
AND CONDITIONS

ENGINEER



STATE OF FLORIDA
DEPARTMENT OF TRANSPORTATION

By: _____
Title: Director of Transportation Development

Legal Review

By: _____
Attorney - DOT Date

Approved to Funds Available

By: _____
Comptroller - FDOT Date

Florida East Coast Railway, LLC

By: _____

Title: A.G. Fowler, Jr. - Chief Engineer, Signal & Communications

COUNTY RESOLUTION
GRADE CROSSING TRAFFIC CONTROL DEVICES AND FUTURE RESPONSIBILITY

FINANCIAL PROJECT NO.	ROAD NAME OR NUMBER	COUNTY NAME	PARCEL & R/W NUMBER	FAP NUMBER
43333015701	Center Street	PALM BEACH	1(93090-SIGW)	00S4-051 J

A RESOLUTION AUTHORIZING EXECUTION OF A RAILROAD REIMBURSEMENT AGREEMENT FOR THE INSTALLATION OF GRADE CROSSING TRAFFIC CONTROL DEVICES, AND FUTURE MAINTENANCE AND ADJUSTMENT OF SAID DEVICES; PROVIDING FOR THE EXPENDITURE OF FUNDS; AND PROVIDING WHEN THIS RESOLUTION SHALL TAKE EFFECT.

RESOLUTION NO. _____

ON MOTION OF Commissioner _____,
seconded by Commissioner _____, the following
RESOLUTION was adopted:

WHEREAS, the State of Florida Department of Transportation is constructing, reconstructing or otherwise changing a portion of the Public Road System, on Center Street which shall call for the installation and maintenance of railroad grade crossing traffic control devices for railroad grade crossing over or near said highway; and

NOW, THEREFORE, BE IT RESOLVED BY THE COUNTY COMMISSION OF _____
COUNTY, FLORIDA;

That PALM BEACH County enter into a RAILROAD REIMBURSEMENT AGREEMENT with the State of Florida Department of Transportation and the FLORIDA EAST COAST RAILWAY L.L.C. Company for the installation and maintenance of certain grade crossing traffic control devices designated as Financial Project Number 43333015701 on Center Street which crosses the right of way and tracks of the Company at FDOT/AAR Crossing No. 272376-U located near TOWN OF JUPITER Florida; and

That the County assume it's share of the costs for future maintenance and adjustment of said grade crossing traffic control devices as designated in the RAILROAD REIMBURSEMENT AGREEMENT; and

That the Chairman and Clerk of the Board of Commissioners be authorized to enter into such agreements with the State of Florida Department of Transportation and the FLORIDA EAST COAST RAILWAY L.L.C. Company as herein described; and

That this RESOLUTION shall take effect immediately upon adoption.

INTRODUCED AND PASSED by the Board of County Commissioners of PALM BEACH
County, Florida, in regular session this _____ day of _____, _____.

Chairman of the Board of County Commissioners

(SEAL)

ATTEST: _____
Clerk of the Board of County Commissioners

STATE OF FLORIDA DEPARTMENT OF TRANSPORTATION
WORK DESCRIPTION
GRADE CROSSING TRAFFIC CONTROL DEVICES

725-090-09
 RAIL
 05/02

FINANCIAL PROJECT NO.	ROAD NAME OR NUMBER	COUNTY NAME	PARCEL & RW NUMBER	FAP NUMBER
43333015701	Center Street	PALM BEACH	1 (93090-SIGW)	00S4-051 J

RAILROAD COMPANY

Florida East Coast Railway L.L.C.

- A. JOB DESCRIPTION & LOCATION: 13 Sets LEDs, 2 Gate Savers, Generator Case
- B. TYPE OF ROADWAY FACILITY: 2 thru lanes & 4 Other Lanes - Urban Major Collector
- C. FDOT/AAR XING NO.: 272376-U RR MILE POST TIE: 283 + 510'
- D. TYPE CROSSING PROPOSED: IV CLASS: III DOT INDEX NO.: 17882

E. STATUS AND PROPOSAL:

1. EXISTING DEVICES: (See Agreement dated _____)

- a. _____ None-New Crossing.
- b. _____ Crossbuck and Disk.
- c. _____ Flashing Signals with Disk.
- d. _____ Flashing Signals with Cantilever.
- e. _____ Flashing Signals with Gates.
- f. XX Flashing Signals with Cantilever and Gates.

2. PROPOSED DEVICES: (Safety Index Rating 482)

- a. _____ No revision required.
- b. _____ Crossbuck and Disk.
- c. _____ Flashing Signals and Disk.
- d. _____ Flashing Signals with Cantilever.
- e. _____ Flashing Signals with Gates.
- f. XX Flashing Signals with Cantilever and Gates.
- g. _____ Relocate existing signal devices:
 - (1) _____ (With-Without) addition of Gates.
 - (2) _____ (With-Without) synchronization with highway traffic signals.
 - (3) _____ (With-Without) constant warning time.

F. COMMUNICATION AND/OR POWER LINE ADJUSTMENTS

- 1. N/A By Others (_____ Company.)
- 2. N/A By Railroad Company.

G. AUTHORITY REQUESTED:

(Draft attached: Yes No.)

- 1. XX Agreement (Third Party Participating Palm Beach County)
- 2. _____ Supplemental Agreement No. _____
- 3. _____ Crossing Permit.
- 4. _____ Estimate for Change Order No. _____
- 5. _____ Letter of Authority.
- 6. _____ Letter of Confirmation (No Cost to Department).

H. OTHER REMARKS:

Negotiations to be completed by:

Signal installation target date: _____

Synchronization: (Draft attached Yes No.)

STATE OF FLORIDA DEPARTMENT OF TRANSPORTATION
RAILROAD GRADE CROSSING TRAFFIC CONTROL DEVICES
ANNUAL MAINTENANCE COSTS

725-090-41
 RAIL
 OGC - 03/12

FINANCIAL PROJECT NO.	ROAD NAME OR NUMBER	COUNTY NAME	PARCEL & R/W NUMBER	FAP NUMBER
43333015701	Center Street	PALM BEACH	1(93090-SIGW)	00S4-051 J

COMPANY NAME: Florida East Coast Railway L.L.C.

A. FDOT/AAR XING NO.: 272376-U

RR MILE POST TIE: 283 + 510'

B. TYPE SIGNALS PROPOSED IV

CLASS III

DOT INDEX: 17882

**SCHEDULE OF ANNUAL COST OF AUTOMATIC
 HIGHWAY GRADE CROSSING TRAFFIC CONTROL DEVICES**

Annual Maintenance Cost Exclusive of Installation

<u>CLASS</u>	<u>DESCRIPTION</u>	<u>COST*</u>
I	Flashing Signals - One Track	\$2,256.00
II	Flashing Signals - Multiple Tracks	\$2,985.00
III	Flashing Signals and Gates - One Track	\$3,402.00
IV	Flashing Signals and Gates - Multiple Tracks	\$4,272.00
V	3 or 4 Quadrant Flashing Signals and Gates - One Track	\$6,726.00
VI	3 or 4 Quadrant Flashing Signals and Gates - Multiple Tracks	\$8,442.00

AUTHORITY: FLORIDA ADMINISTRATIVE RULE 14-57.011
 Public Railroad-Highway Grade Crossing Costs

EFFECTIVE DATE: July 22, 1982

GENERAL AUTHORITY: 334.044, F.S.

SPECIFIC LAW IMPLEMENTED: 335.141, F.S.

*This schedule will become effective July 1, 2011 and will be reviewed every 5 years and revised as appropriate based on the Consumer Price Index for all Urban Consumers published by the U.S. Department of Labor.

STATE OF FLORIDA
DEPARTMENT OF TRANSPORTATION

OFFICE OF MODAL DEVELOPMENT
DISTRICT 4 RAIL OFFICE

PROJECT SCOPE AND COST ESTIMATE

PROJECT INFORMATION

Financial Project No.: 433330-1-57-01
FAP Number: 00S4-051 J
Location: Center Street
County: Palm Beach
Crossing No.: 272376-U
RR. MP.: 283 + 510'
Company: Florida East Coast Railway, L.L.C.

*This project scope and cost estimate was prepared by: District 4 Railroad
Coordinator's Office*

13 sets of LED Flashing Lights, Generator Case, 2 gate savers..... \$ 67,680.00

TOTAL ESTIMATED COSTS.....\$ 67,680.00



Florida East Coast
RAILWAY, L.L.C.

2013 Diagnostics

OFFICE OF THE ASSISTANT CHIEF ENGINEER
OF SIGNALS AND COMMUNICATIONS

DATE: 09/12/12
TYPE: 4
CLASS: 3
NO. OF DAYS: 3
AAR / DOT #: 272376J
MILE POST: 283 + 510'
Project Type: FDOT

ESTIMATED COST FOR HIGHWAY CROSSING WARNING DEVICES AT CENTER STREET.
This estimate should be considered void after one (1) year.

MATERIAL	UNIT COST	UNITS	TOTAL COST
12" LED LIGHTS COMPLETE	\$250.00	26 EA.	\$6,500.00
NEG GATE SAVER SADDLE	\$1,168.00	2 EA.	\$2,336.00
GENERATOR CASE W/ TRANSFER SWITCH	\$5,615.00	1 EA.	\$5,615.00
MISC. GROUND MATERIAL	\$795.80	1 PKG.	\$795.80
SANITATION & DISPOSAL	\$1,500.00	1 PKG.	\$1,500.00
FREIGHT & HANDLING			\$3,812.00
TAX @ 6.5%			<u>\$991.00</u>
TOTAL MATERIALS			\$21,549.80
EXCAVATING EQUIPMENT PER DAY	\$417.10	3 DAYS	\$1,251.30
EQUIPMENT RENTAL PER DAY	\$200.00	3 DAYS	\$600.00
FOREMAN'S TRUCK PER DAY	\$224.70	3 DAYS	\$674.10
GANG TRUCK PER DAY	\$647.30	3 DAYS	\$1,941.90
SUPERVISORS TRUCK PER DAY	\$142.60	3 DAYS	<u>\$427.80</u>
EQUIPMENT TOTAL			\$4,895.00
DESIGN ENGINEERING	\$7,500.00	1	\$7,500.00
CONTRACT ENGINEERING	\$12,650.00	1	\$12,650.00
CONSTRUCTION ENGINEERING INSPECTION	\$1,350.00	3 DAYS	<u>\$4,050.00</u>
ENGINEERING TOTAL			\$24,200.00
CONSTRUCTION SUPERVISION	\$375.00	3 DAYS	\$1,125.00
LABOR ADDITIVE			<u>\$650.00</u>
TOTAL SUPERVISION LABOR			\$1,775.00
LABOR PER DAY	\$1,392.40		\$4,177.00
NUMBER OF DAYS	3		
LABOR ADDITIVE			<u>\$2,456.00</u>
TOTAL GANG LABOR			\$6,633.00
GANG EXPENSES PER DAY	\$803.00		
NUMBER OF DAYS	3		
TOTAL GANG EXPENSES			\$2,409.00
ESTIMATED FLAGGING TOTAL	\$1,000.00	3 DAYS	\$3,000.00
SUB-TOTAL			\$64,461.80
CONTINGENCIES 5%			<u>\$3,223.00</u>
TOTAL			\$67,680.00

ESTIMATE NOTES:

Crossing No: 272376U Roadway: CENTER ST RR Street District: 4 County: Palm Beach
 PUBLIC Highway Vehicle AT GRADE Commercial City: Tequesta IN CITY

Rank 2012: 482 SR No.: RR Company: FEC Date: 07/16/2012
 Rank 2011: 513 CR No.: Division Name:
 Rank 2010: 512 US No.: Subdivision Name:
 Latitude: 26.941500 Branch Name: MAIN
 Longitude: -80.090000 RR Milepost: 283.10

Field Review Comments:
 Team Recommendations: 13 sets of LEDs, 2 gate savers, gen case.

Highway Speed: 35	<input type="checkbox"/>	Train Speed Range: 35-45	<input type="checkbox"/>
Crossing Angle: 60-90 DEG	<input type="checkbox"/>	Max Time Table Speed: 60	<input type="checkbox"/>
AAADT: 14221 (2009)	<input type="checkbox"/>	Day Thru/Switch: 12/0	<input type="checkbox"/>
Percent Trucks: 0 (2009)	<input type="checkbox"/>	Night Thru/Switch: 12/0	<input type="checkbox"/>
School Buses: 30 (2012)	<input type="checkbox"/>	Train Service: Freight	<input type="checkbox"/>
Street Types: Two-Way Street	<input type="checkbox"/>	Passenger Count/Day:	<input type="checkbox"/>
Thru Lanes: 2	<input type="checkbox"/>	Train Count Date: 01/24/2000	<input type="checkbox"/>
Aux Lanes: 4	<input type="checkbox"/>	Main Tracks: 1	<input type="checkbox"/>
Hazmat Route?	<input type="checkbox"/>	Other Tracks: (0)	<input type="checkbox"/>
Emergency Services Route?	<input type="checkbox"/>		<input type="checkbox"/>

Emergency Notification Signs: NO	<input type="checkbox"/>	Train Signals? YES	<input type="checkbox"/>
Crossbuck(4x4 post): 0	<input type="checkbox"/>	Train Signal Proximity: NO	<input type="checkbox"/>
Crossbuck Sign: 6	<input type="checkbox"/>	Train Detection: Other	<input type="checkbox"/>
Stop Sign: 0	<input type="checkbox"/>	Number of Bells: 1	<input type="checkbox"/>
Yield Sign: 0	<input type="checkbox"/>	Post Mounted Flashing Lights: 2	<input type="checkbox"/>
Low Ground Clearance Signs: 0	<input type="checkbox"/>	Roadway Gate Count: 2	<input type="checkbox"/>
Exempt Signs: NO	<input type="checkbox"/>	Pedestrian Gate Count: 0	<input type="checkbox"/>
Trespass Signs: YES	<input type="checkbox"/>	Gates: 2 Quad	<input type="checkbox"/>

W10-1 2	R10-6a	W8-1	Cantilevered Flashing Over Traffic: 2	<input type="checkbox"/>
W10-2 2	R11-2	W10-8	Cantilevered Flashing Not Over Traffic: 0	<input type="checkbox"/>
W10-3	R15-2P	W10-9	Intersecting Roadway? YES	<input type="checkbox"/>
W10-4	R15-6	W10-9P	Signalized? YES	<input type="checkbox"/>
W10-11	R15-6a	W10-11a	Interconnection: For Traffic Signals	<input type="checkbox"/>
W10-12	R15-7	W10-11b	Preemption: SIMULTANEOUS PREEMPTION	<input type="checkbox"/>
R3-1a	R15-7a	W10-13P	Traffic Pre-Signals? NO	<input type="checkbox"/>
R3-2a	R15-8	W10-14P	8" Count: 0	<input type="checkbox"/>
R8-8 2	Pvt Crossing	W10-14aP	12" Count: 13	<input type="checkbox"/>
R8-9	Look Out	W10-15P	LED Count: 0	<input type="checkbox"/>
R8-10	R8-8 w/Beacon	Slow	Install - Upgrade: - 05/12/1983	<input type="checkbox"/>
R8-10a	W3-1	W10-1w/Beacon		<input type="checkbox"/>
R10-6	W3-3	LED Signs 0		<input type="checkbox"/>

Surface Installment Date:	<input type="checkbox"/>	Maintenance Responsibility: COUNTY	<input type="checkbox"/>
Surface Type: CONCRETE	<input type="checkbox"/>	Roadway Paved: YES	<input type="checkbox"/>
Pvmt Mrk: STOPLINES AND XING SYMBOLS	<input type="checkbox"/>	Tracks run down street? NO	<input type="checkbox"/>
Surface Condition: EXCELLENT	<input type="checkbox"/>	Sidewalks on Crossing Approach? NO	<input type="checkbox"/>
Approach: LOS A = Smooth	<input type="checkbox"/>	Sidewalks Thru Crossing? N/A	<input type="checkbox"/>
Vehicle Reaction: LOS B = Vibrating	<input type="checkbox"/>	Crossing illuminated? YES	<input type="checkbox"/>
Driver Reaction: = Some drivers slow down	<input type="checkbox"/>	Commerical Power? YES	<input type="checkbox"/>
Rail/Pad Movement: LOS A = Smooth	<input type="checkbox"/>	Alternative Power? NO	<input type="checkbox"/>

Recommended Warning Device: Incident History: 6/87

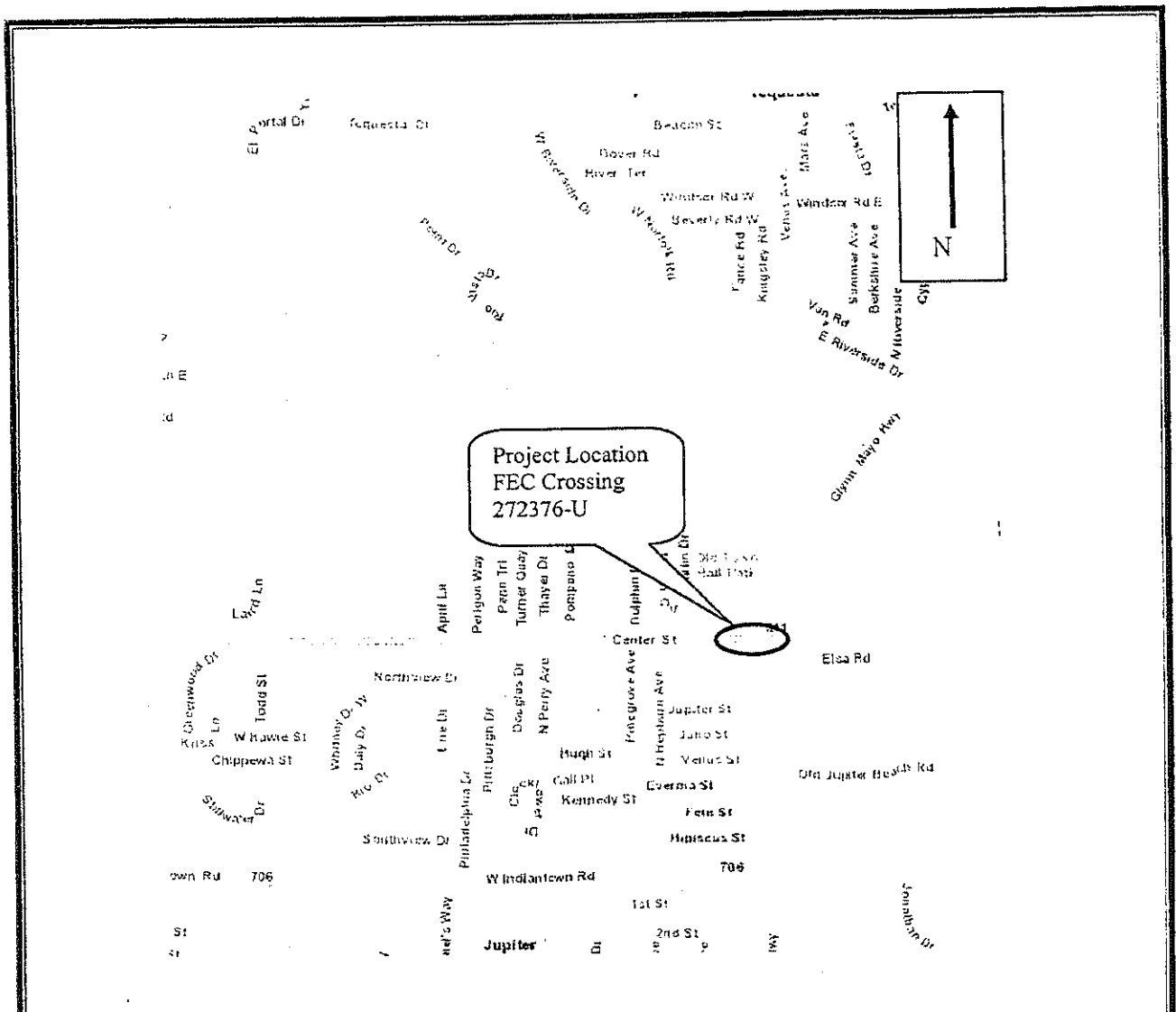

LOCATION MAP

Florida East Coast Railway L.L.C.

LOCATION:	Center Street, Palm Beach County
FINANCIAL PROJECT NO.:	433330-1-57-01
CROSSING NO.:	272376-U
RAILROAD MILEPOST:	283 + 510'

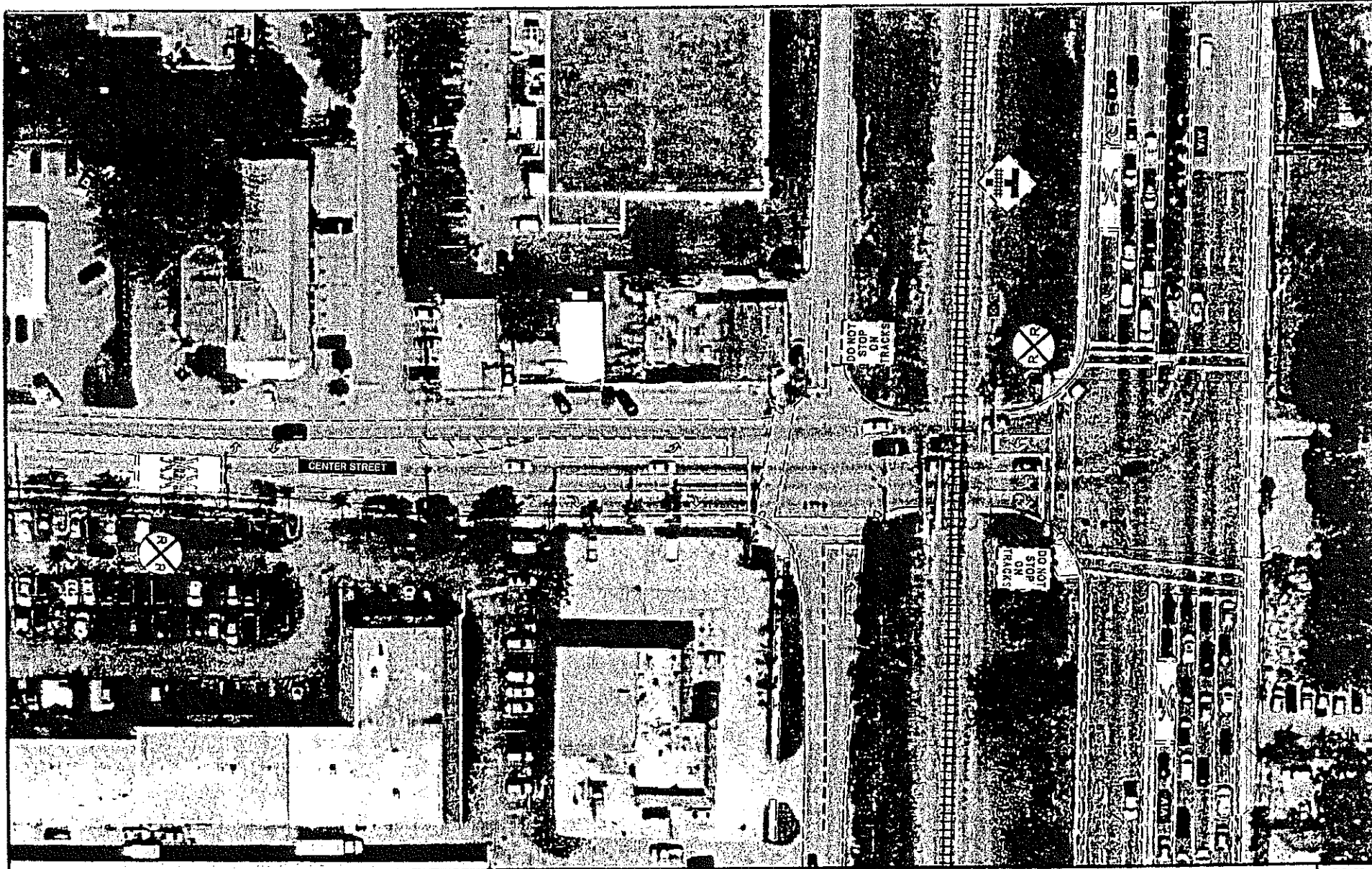

<p>C. H. Perez & Associates Consulting Engineers Certificate of Authorization: EB-25476 9544 NW 41 Street, Suite 201 Doral, Florida 33178 Tel. (305) 592-1070 Fax. (305) 592-1078</p>				<p>STATE OF FLORIDA DEPARTMENT OF TRANSPORTATION</p>		<p>CENTER STREET, TEQUESTA RR CROSSING NO. 272376U</p>		<p>FIGURE NO.</p>
<p>SIGN PANEL</p>	<p>CONTROLLER</p>	<p>CANTILEVER</p>	<p>RAIL ROAD</p>	<p>BRIDGE</p>	<p>ROAD NO.</p>	<p>TEAM#</p>	<p>FINANCIAL PROJECT ID</p>	
<p>LIGHT POLE</p>	<p>GATE ARM</p>	<p>TRAFFIC LIGHT</p>			<p>PALM BEACH</p>	<p>433350-1</p>		
<p>BATTERY</p>								

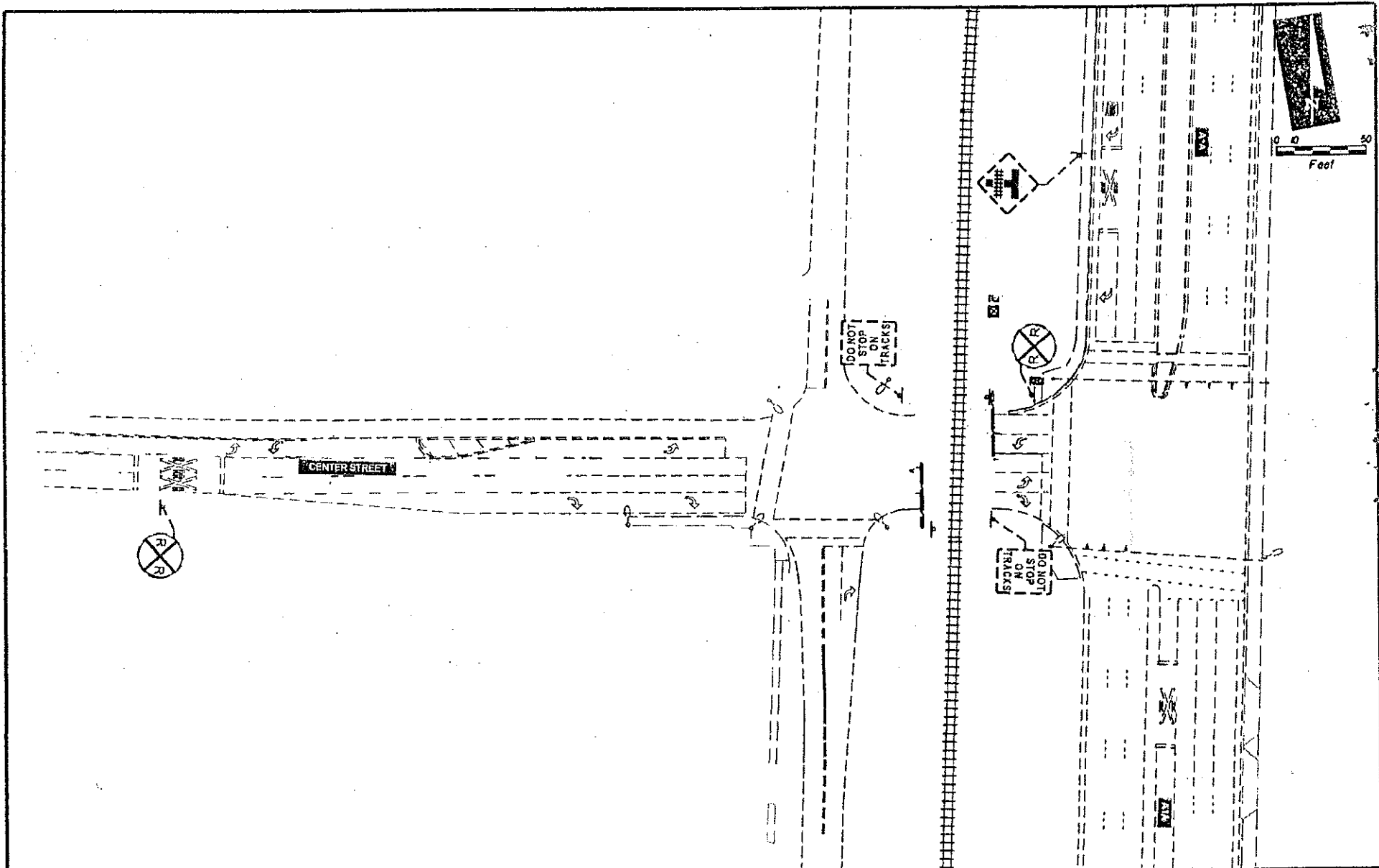

SIGN PANEL LIGHT POLE BATTERY				CONTROLLER RAIL ROAD GATE ARM		CANTILEVER BRIDGE TRAFFIC LIGHT		C. H. Perez & Associates Consulting Engineers Certificate of Authorization: EB-25976 9554 NW 41 Street, Suite 201 Doral, Florida 33176 Tel. (305) 592-1070 Fax. (305) 592-1074	STATE OF FLORIDA DEPARTMENT OF TRANSPORTATION		CENTER STREET, TEQUESTA RR CROSSING NO. 272376U	FIGURE NO.
ROAD NO.	COUNTY	FISCAL PROJECT ID		PALM BEACH	433334-I							

11/2/2011 2:42:14 PM TRANSPORTATION PROJECTS/TEQUESTA/RR CROSSING NO. 272376U

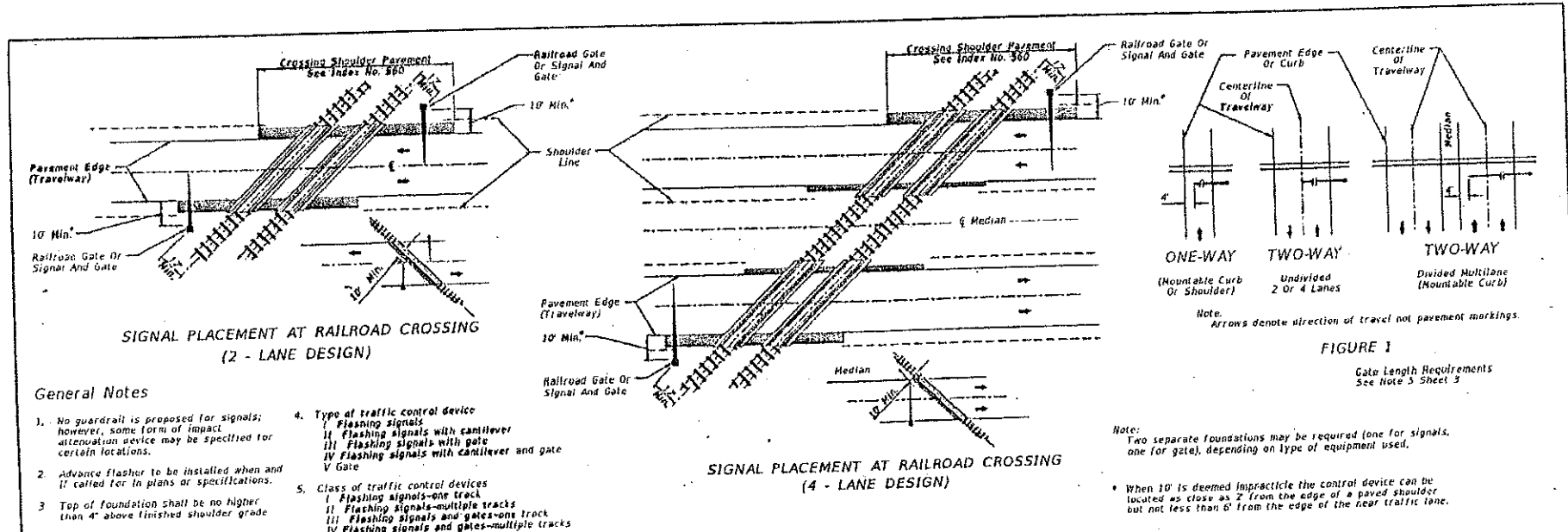

General Notes

- No guardrail is proposed for signals; however, some form of impact attenuation device may be specified for certain locations.
- Advance flasher to be installed when and if called for in plans or specifications.
- Top of foundation shall be no higher than 4" above finished shoulder grade.
- Type of traffic control device
 - Flashing signals
 - Flashing signals with cantilever
 - Flashing signals with gate
 - Flashing signals with cantilever and gate
 - Gate
- Class of traffic control devices
 - Flashing signals-one track
 - Flashing signals-multiple tracks
 - Flashing signals and gates-one track
 - Flashing signals and gates-multiple tracks

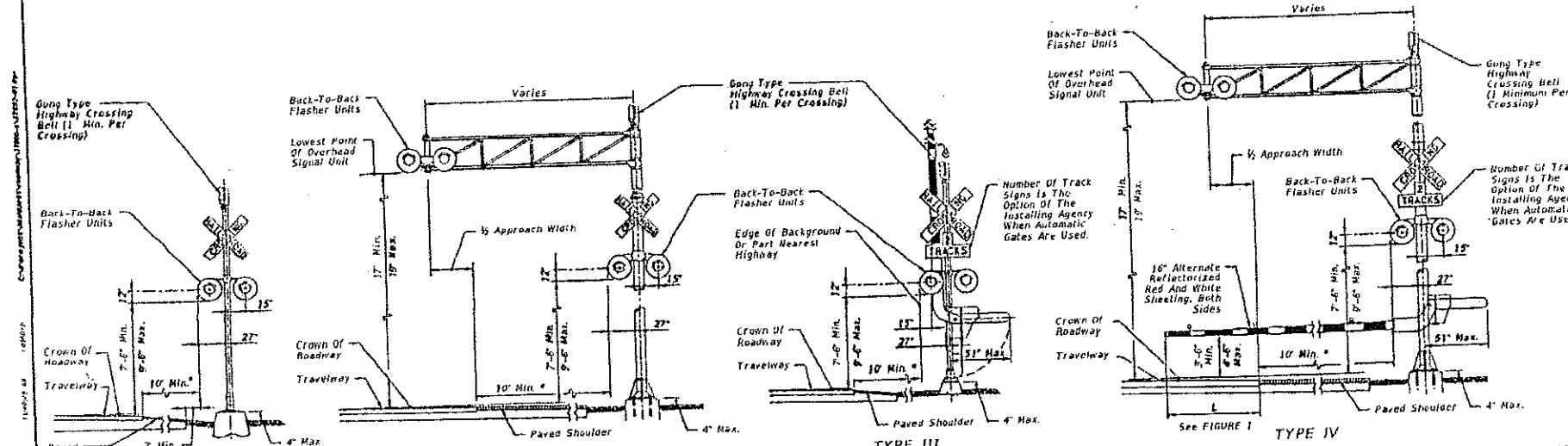

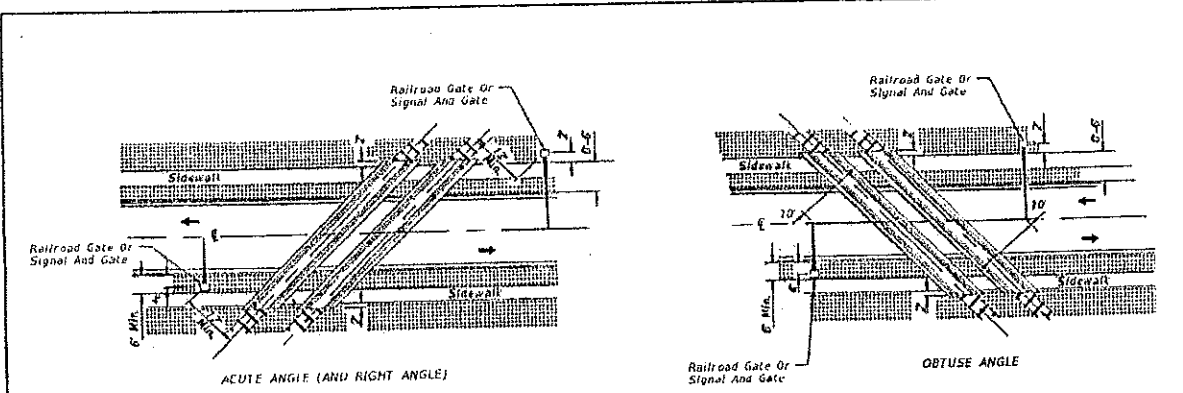

SIGNAL PLACEMENT AT RAILROAD CROSSING
(2 LANES, CURB & GUTTER)

SIGNAL PLACEMENT AT RAILROAD CROSSING
(2 LANES, CURB & GUTTER)

GENERAL NOTES

1. The location of flashing signals and stop lines shall be established based on future (or present) installation of gate with appropriate track clearances.
2. Where plans call for railroad traffic control devices to be installed in cutback medians, the minimum median width shall be 12'-6".
3. Location of railroad traffic control device is based on the distance available between face of curb & sidewalk, 0' to 6' - Locate device outside sidewalk Over 6' - Locate device between face of curb and sidewalk.
4. Stop line to be perpendicular to edge of roadway, approx. 15' from nearest rail, or 8' from and parallel to gate when present.
5. When a cantilevered-arm flashing-light signal is used, the minimum vertical clearance shall be 17' from above the Crown of Roadway to the Lowest Point of the Overhead Signal Unit.

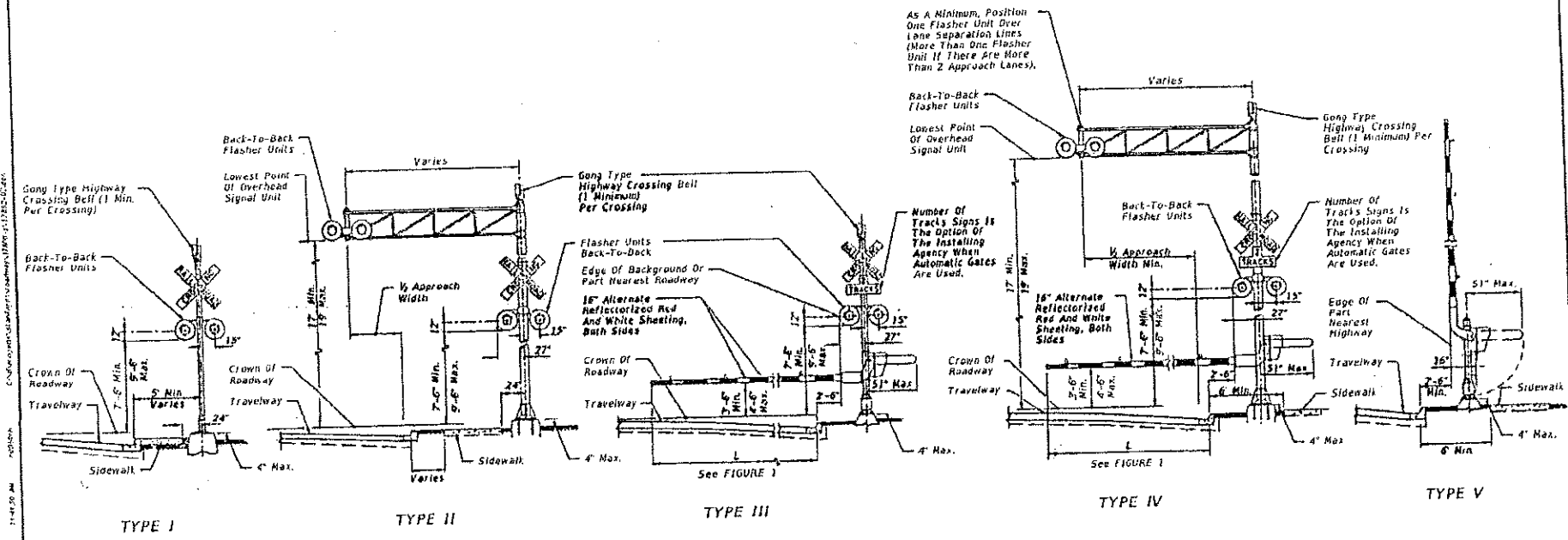

LAST REVISION: 01/01/11 DESCRIPTION:			FDOT DESIGN STANDARDS FY 2012/2013	RAILROAD GRADE CROSSING TRAFFIC CONTROL DEVICES		INDEX NO. 17882	SHEET NO. 2

RAILROAD CROSSING AT TWO (2)-LANE ROADWAY

RAILROAD CROSSING AT MULTILANE ROADWAY

RELATIVE LOCATION OF CROSSING TRAFFIC CONTROL DEVICES

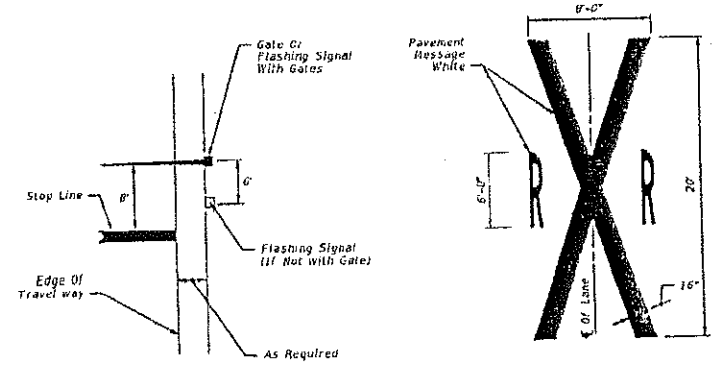
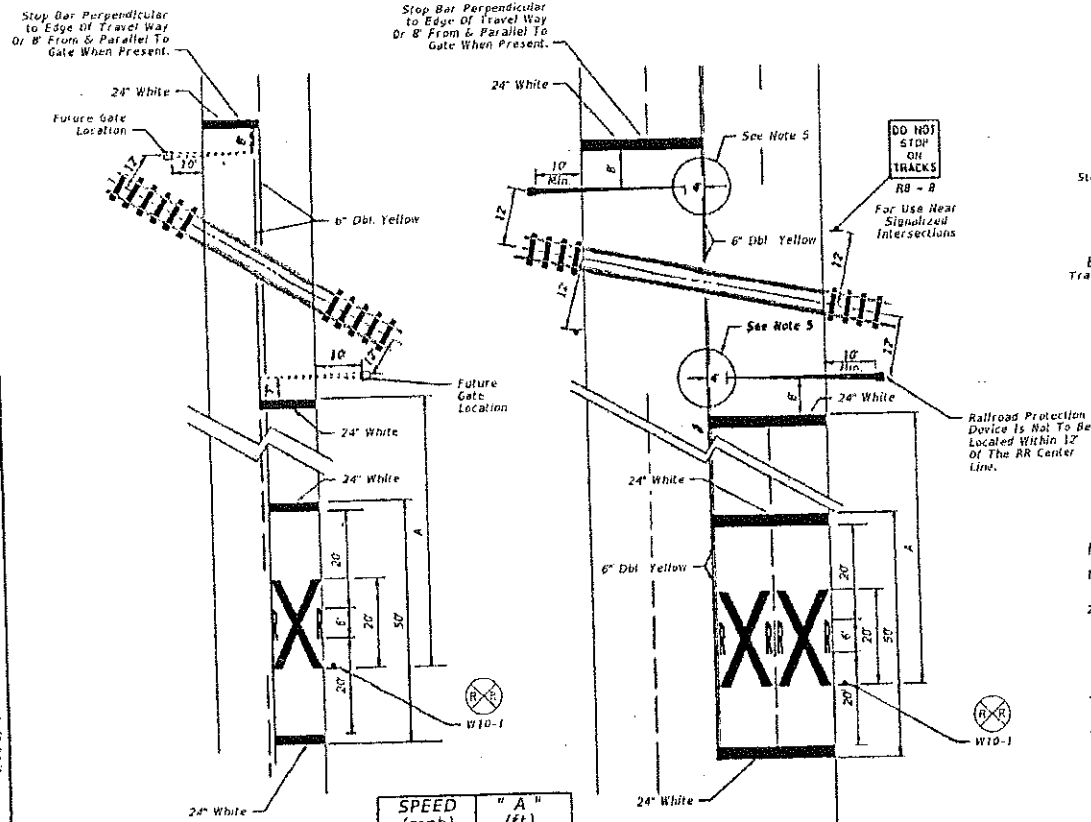

- NOTES:**
- When computing pavement message, quantities do not include traverse lines.
 - Placement of sign W10-1 in a residential or business district, where low speeds are prevalent, the W10-1 sign may be placed a minimum distance of 100' from the crossing. Where street intersections occur between the RR pavement message and the tracks an additional W10-1 sign and additional pavement message should be used.
 - A portion of the pavement markings symbol should be directly opposite the W10-1 sign.
 - Recommended location for FTP-61-06 or FTP-62-05 signs, 100' urban and 300' rural. See Index 17355 for sign details.
 - Gate Length Requirements:**
 For two-way undivided sections:
 The gate should extend to within 1' of the center line. On multiple approaches the maximum gate length may not reach to within 1' of the center line. For those cases, the distance from the gate to the center line shall be a maximum of 4'.
 For one-way or divided sections:
 The gate shall be of sufficient length such that the distance from the gate tip to the inside edge of pavement is a maximum of 4'.

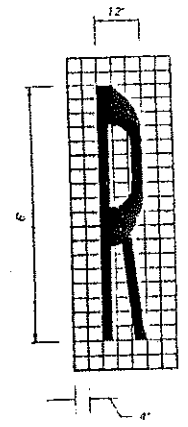

SPEED (mph)	" A " (ft)
60	400
55	325
50	250
45	175
40	125
35	100
URBAN	85 MIN.

12/20/2011 11:00:00 AM C:\pds\pds\standards\standards\index\17355.rvt

LAST REVISION	DESCRIPTION
07/01/10	



FDOT DESIGN STANDARDS
FY 2012/2013

RAILROAD GRADE CROSSING
TRAFFIC CONTROL DEVICES

INDEX NO. 17882	SHEET NO. 3
--------------------	----------------

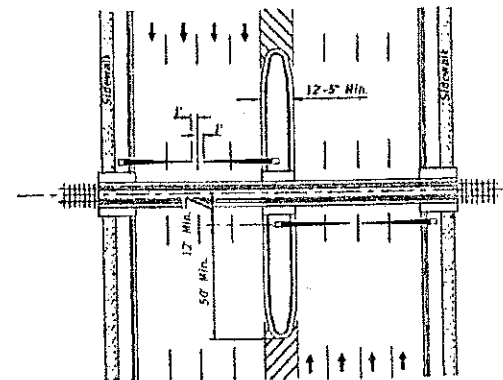
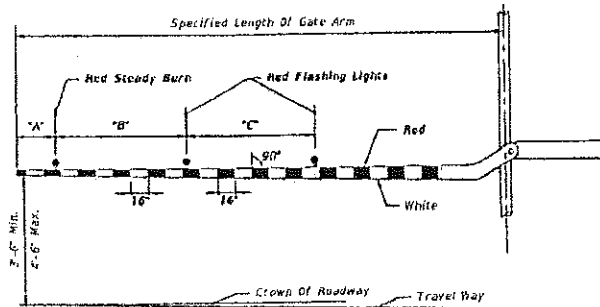

PLAN

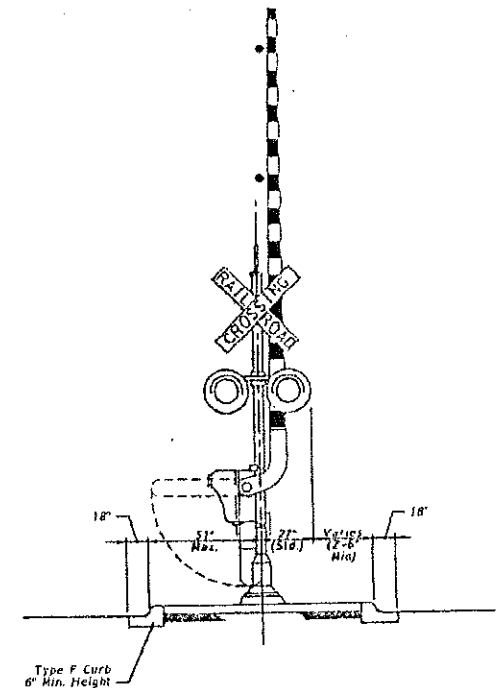

MEDIAN SECTION AT SIGNAL GATES

RAILROAD GATE ARM LIGHT SPACING

Specified Length Of Gate Arm	Dimension "A"	Dimension "B"	Dimension "C"
14 Ft.	6"	36"	5"
15 Ft.	18"	36"	5"
16-17 Ft.	24"	36"	5"
18-19 Ft.	20"	41"	5"
20-23 Ft.	20"	4"	5"
24-28 Ft.	20"	5"	5"
29-31 Ft.	36"	6"	6"
32-34 Ft.	36"	7"	7"
35-37 Ft.	36"	9"	9"
38 And Over	36"	10"	10"

NOTE:
For additional information see the "Manual On Uniform Traffic Control Devices", Part B; The "Traffic Control Handbook", Part VIII; and AASHTO "A Policy On Geometric Design Of Streets And Highways".

MEDIAN SIGNAL GATES FOR
MULTILANE UNDIVIDED URBAN SECTIONS
(THREE OR MORE DRIVING LANES IN ONE DIRECTION, 45 MPH OR LESS)

11/16/12, AS

LAST REVISION	DESCRIPTION
01/01/12	



FDOT DESIGN STANDARDS
FY 2012/2013

RAILROAD GRADE CROSSING
TRAFFIC CONTROL DEVICES

INDEX NO.	SHEET NO.
17882	4