



**II. FISCAL IMPACT ANALYSIS**

**A. Five Year Summary of Fiscal Impact:**

Fiscal Years	<u>2017</u>	<u>2018</u>	<u>2019</u>	<u>2020</u>	<u>2021</u>
Capital Expenditures	_____	_____	_____	_____	_____
Operating Costs	_____	_____	_____	_____	_____
Operating Revenues	<u>\$-0-</u>	<u>\$-0-</u>	<u>\$-0-</u>	<u>\$-0-</u>	<u>\$-0-</u>
Program Income (County)	_____	_____	_____	_____	_____
In-Kind Match (County)	_____	_____	_____	_____	_____
<b>NET FISCAL IMPACT *</b>	<u><u>\$-0-</u></u>	<u><u>\$-0-</u></u>	<u><u>\$-0-</u></u>	<u><u>\$-0-</u></u>	<u><u>\$-0-</u></u>
# ADDITIONAL FTE POSITIONS (Cumulative)	_____	_____	_____	_____	_____

Is Item Included in Current Budget? Yes X No \_\_\_\_\_  
 Budget Account No: Fund 4100 Department 120 Unit 8430 RSource 4414  
 Reporting Category \_\_\_\_\_

**B. Recommended Sources of Funds/Summary of Fiscal Impact:**

\*The relocation of American Airlines' gate area from B10 to B12 was effective January 17, 2017. As there was no change in the amount of square footage leased, there is no fiscal impact. The Signatory Airline Agreement expires on September 30, 2019.

C. Departmental Fiscal Review: CM Sumner

**III. REVIEW COMMENTS**

**A. OFMB Fiscal and/or Contract Development and Control Comments:**

[Signature]  
 OFMB ET/124

[Signature] 1/26/17  
 Contract Dev. and Control  
 1/25/17 [initials]

**B. Legal Sufficiency:**

Anne Delmont 1-26-17  
 Assistant County Attorney

**C. Other Department Review:**

\_\_\_\_\_  
 Department Director

REVISED 9/03  
 ADM FORM 01  
 (THIS SUMMARY IS NOT TO BE USED AS A BASIS FOR PAYMENT)

**FIRST AMENDMENT TO SIGNATORY AIRLINE AGREEMENT BETWEEN PALM BEACH COUNTY AND AMERICAN AIRLINES, INC**

**THIS FIRST AMENDMENT TO THE SIGNATORY AIRLINE AGREEMENT** (this "Amendment") is made and entered into JAN 17 2017, 20\_\_, by and between Palm Beach County, a political subdivision of the State of Florida ("COUNTY"), and American Airlines, Inc., a Delaware corporation, having its office and principal place of business at 4333 Amon Carter Blvd., MD 5317, Fort Worth, Texas 76155 ("Airline").

**WITNESSETH:**

**WHEREAS**, COUNTY, by and through its Department of Airports (the "Department"), owns and operates the Palm Beach International Airport, located in Palm Beach County, Florida; and

**WHEREAS**, pursuant to the Signatory Airline Agreement between COUNTY and AIRLINE dated June 13, 2016 (R2016-0974) (the "Agreement"), AIRLINE leases various Airport Terminal facilities and equipment in connection with its operations as a commercial air carrier; and

**WHEREAS**, the Director of the Department has been delegated the authority to execute certain amendments to the Agreement pursuant to County Resolution No. 2014-1033; and

**WHEREAS**, the parties desire to amend the Agreement as provided for herein.

**NOW, THEREFORE**, in consideration of the premises and of the mutual covenants herein contained, and for other good and valuable consideration, the receipt of which the parties hereby expressly acknowledge, the parties hereto covenant and agree to the following terms and conditions:

1. The foregoing recitals are true and correct and are hereby incorporated herein by reference and made a part hereof. Terms not defined herein shall have the meaning ascribed to them in the Agreement.

2. The parties agree that Exhibit "B" to the Agreement (Preferential Use Premises – Terminal Areas) shall be deleted in its entirety and replaced with Exhibit "B" to this Amendment.

3. The parties agree that Exhibit "C" to the Agreement (Preferential Use Premises – Gate Areas) shall be deleted in its entirety and shall be replaced with Exhibit "C" to this Amendment.

4. Exhibits attached hereto and referenced herein shall be deemed to be incorporated in this Amendment by such reference.

5. Except as specifically modified herein, all of the terms and conditions of the Agreement shall remain unmodified and in full force and effect and are hereby ratified and confirmed by the parties hereto.

6. This Amendment shall become effective when signed by both the parties hereto.

*(Remainder of page intentionally left blank)*

**IN WITNESS WHEREOF**, the parties hereto have duly executed this Amendment as of the day and year first above written

Signed, sealed and delivered in the presence of two (2) witnesses for COUNTY:

**PALM BEACH COUNTY, a political subdivision of the State of Florida**

Jeffrey S. Bolton  
Signature  
Jeffrey S. Bolton

BY: [Signature]  
Director, Department of Airports

Print Name

Debra Reese  
Signature  
Debra Reese  
Print Name

**APPROVED AS TO FORM & LEGAL SUFFICIENCY:**

Anne Delgent  
County Attorney

ATTEST:

**AIRLINE: American Airlines Inc.**

By: [Signature]

(Seal)

Kirk Hotelling  
Typed or Printed Name of Corporate Officer  
Managing Director - Corporate Real Estate  
Title: \_\_\_\_\_

Signed, sealed and delivered in the presence of two witnesses for Airline:

Karen Jackson  
Witness Signature  
Karen Jackson

Donna Robinson  
Witness Signature  
Donna Robinson

EXHIBIT "B" - Preferential Use Premises (Terminal Areas)  
 American Airlines, Inc.  
 First Level Plan – Palm Beach International Airport Main Terminal

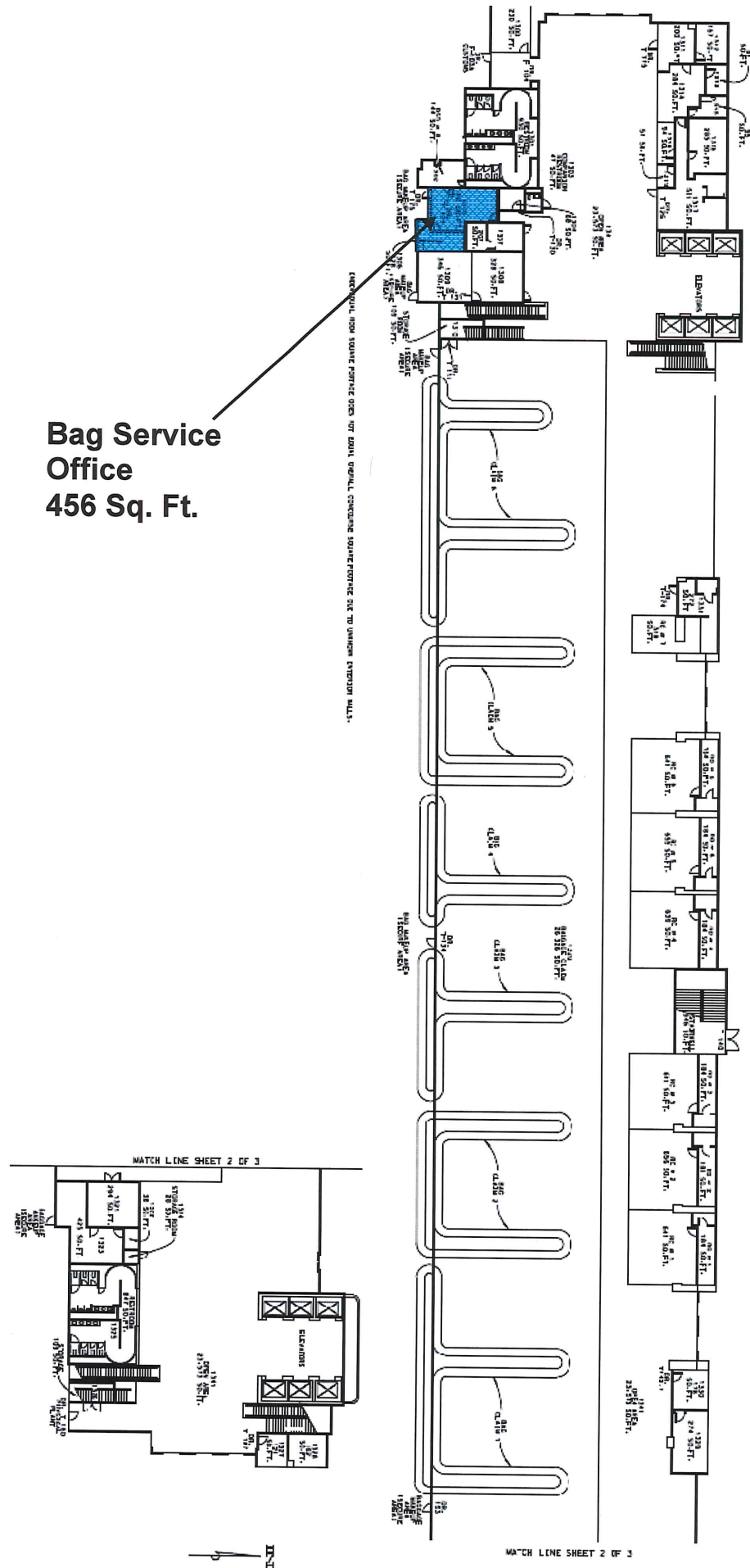

**Bag Service  
 Office  
 456 Sq. Ft.**

EXHIBIT "B" - Preferential Use Premises (Terminal Areas)  
 American Airlines, Inc.  
First Level Plan – Palm Beach International Airport Concourse

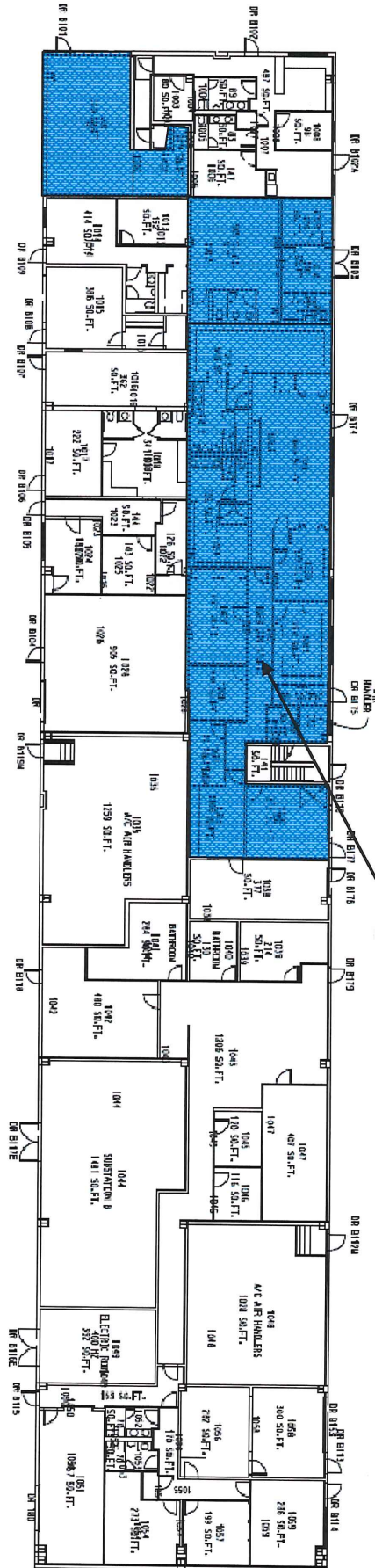

POD B-1

**Operations Area  
 4,788 Sq. Ft.**

EXHIBIT "B" - Preferential Use Premises (Terminal Areas)  
American Airlines, Inc.  
Second Level Plan – Palm Beach International Airport

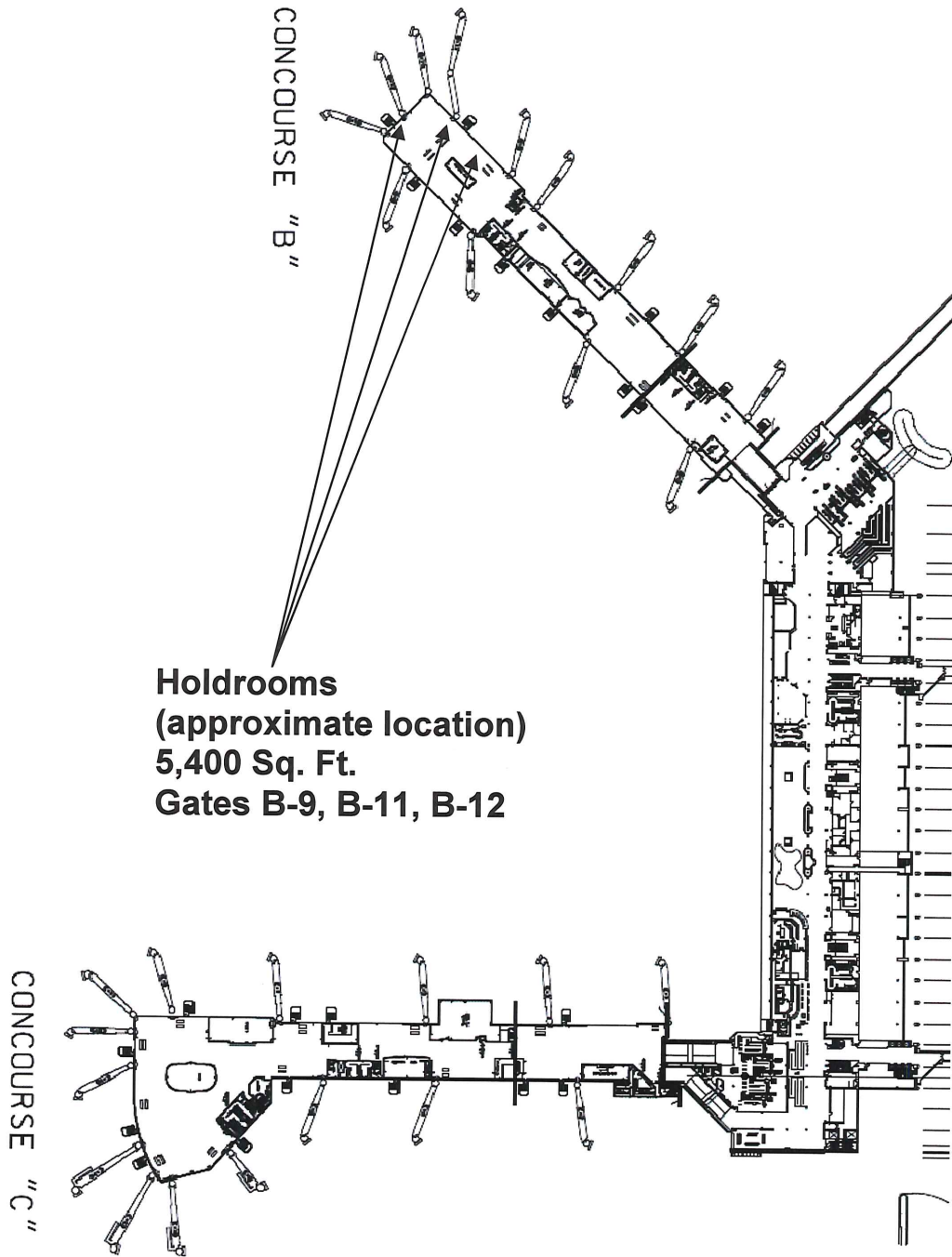



EXHIBIT "B" - Preferential Use Premises (Terminal Areas)  
 American Airlines, Inc.  
 Third Level Plan – Palm Beach International Airport Main Terminal

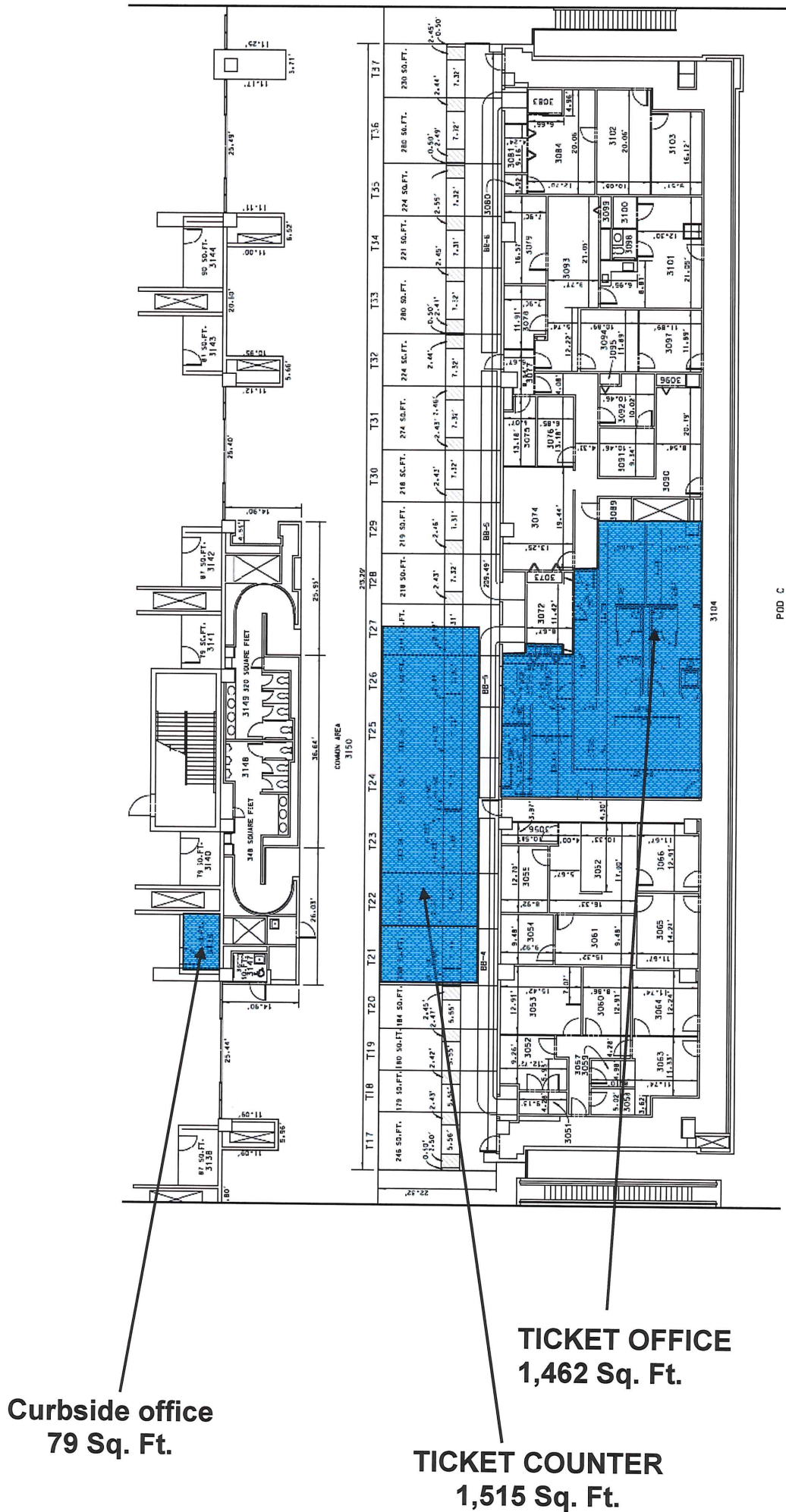
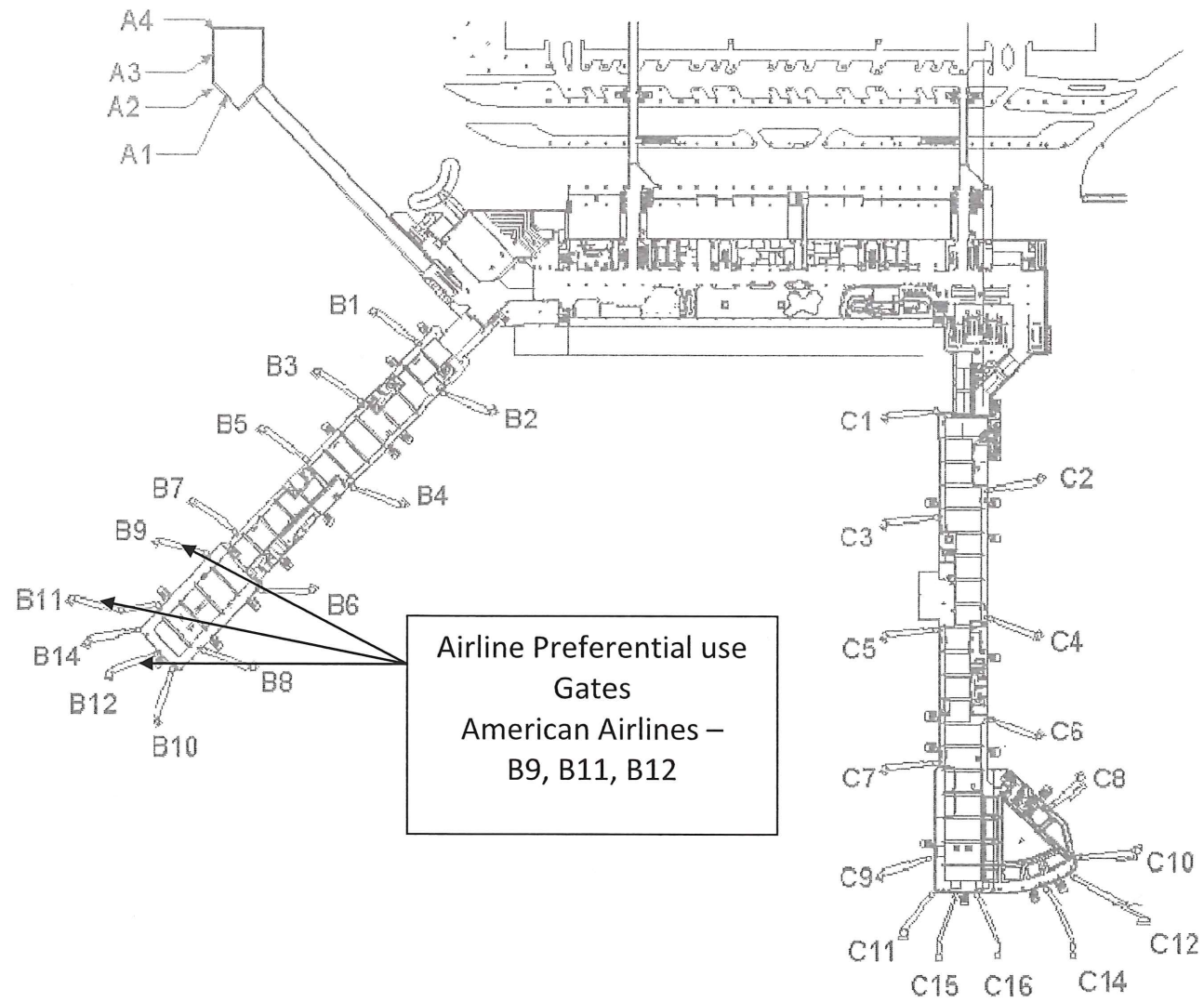



EXHIBIT "C" – Preferential Use Premises (Gate Areas)  
American Airlines, Inc.



## Summary of Certificates

This report displays detailed Certificate of Insurance information for a selected Insured. Any items shown in red are deficient.

Tuesday, January 17, 2017

Insured: American Airlines, Inc.

Insured ID: **PBI-AM-14-02**

Status: **Compliant**

ITS Account Number: **PLC1806**

Project(s): **Palm Beach County - Airport Properties**

Insurance Policy	Required	Provided	Override
<u>General Liability</u>			
Expiration: 12/22/2017			
General Aggregate:	\$100,000,000	\$100,000,000	
Products - Completed Operations Aggregate:	\$100,000,000	\$100,000,000	
Personal And Advertising Injury:	\$25,000,000	\$25,000,000	
Each Occurrence:	\$100,000,000	\$100,000,000	
Fire Damage:	\$0	\$0	
Medical Expense:	\$0	\$0	
<u>Workers Compensation/Employers Liability</u>			
Expiration: 7/1/2017			
Each Accident:	\$1,000,000	\$1,000,000	
Disease - Policy Limit:	\$1,000,000	\$1,000,000	
Disease - Each Employee:	\$1,000,000	\$1,000,000	
<u>Aircraft Liability Insurance</u>			
Expiration: 12/22/2017			
Each Occurrence:	\$100,000,000	\$100,000,000	
Aggregate Limit:	\$100,000,000	\$100,000,000	

Notifications ([Show All](#))

The following letters were issued:

**Dec 19 2016 - Renewal Letter**

Do you have an updated Certificate? Click the button below to submit a Certificate.

**Incumbency Certificate**

I, Caroline Ray, the Corporate Secretary of American Airlines, Inc. (the "Company"), am authorized to execute and deliver this Certificate on behalf of the Company and hereby certify that Kirk Hotelling is authorized to sign the Signatory Airline Agreement by and between Palm Beach County, a political subdivision of the State of Florida and American Airlines, Inc., a Delaware corporation. I also certify that Kirk Hotelling is authorized to sign the License Agreement by and between Palm Beach County, a political subdivision of the State of Florida, and American Airlines, Inc.

Name

Position

Kirk Hotelling

Managing Director - Corporate Real Estate

IN WITNESS WHEREOF, I have hereto set my hand and the seal of the Company this 23<sup>rd</sup> day of September, 2014.

Caroline B. Ray

Caroline Ray

Corporate Secretary