

PALM BEACH COUNTY
BOARD OF COUNTY COMMISSIONERS
AGENDA ITEM SUMMARY

Meeting Date: June 6, 2017

Consent

Regular

Public Hearing

Workshop

Department: Engineering & Public Works

Submitted By: Engineering & Public Works

Submitted For: Roadway Production Division

I. EXECUTIVE BRIEF

Motion and Title: Staff recommends motion to adopt: a resolution authorizing execution of a tri-party railroad reimbursement agreement with the Florida Department of Transportation (FDOT) and the South Florida Regional Transportation Authority (SFRTA) for the installation and maintenance of upgraded railroad grade crossing traffic control devices at the SFRTA crossing on Palmetto Park Road, DOT/AAR Crossing Number 628165L.

SUMMARY: The SFRTA will be responsible for installing the traffic control devices and the FDOT will reimburse the SFRTA for all installation costs. Palm Beach County (County) holds the license agreement for this crossing and will continue to pay 50 percent of the annual signal maintenance fee which is currently \$2,260 for this Class IV crossing. District 4 LBH

Background and Justification: The FDOT is upgrading the grade crossing traffic control devices on Palmetto Park Road, DOT/AAR Crossing Number 628165L. The SFRTA or its contractor will perform all work associated with the installation of the devices and the FDOT will reimburse the SFRTA for all material and construction costs. The FDOT owns the railroad corridor property and, in collaboration with SFRTA, manages and maintains the railroad line. SFRTA will be responsible for maintenance and operation of the devices. The County holds the license agreement for this crossing and will continue to pay 50 percent of the annual signal maintenance fee which is currently \$2,260. The other 50 percent of the annual signal maintenance fee is paid by SFRTA and FDOT.

Attachments:

1. Location Map
2. Resolution (4)
3. Tri-Party Agreement with FDOT and SFRTA (4)

Recommended By: *STW*

S. T. Webb
Department Director

4/26/17
Date

Approved By: *AKS*

are Johnson
Assistant County Administrator

5/8/17
Date

PALMETTO PARK ROAD RAILROAD CROSSING

DOT/AAR CROSSING NUMBER 628165L

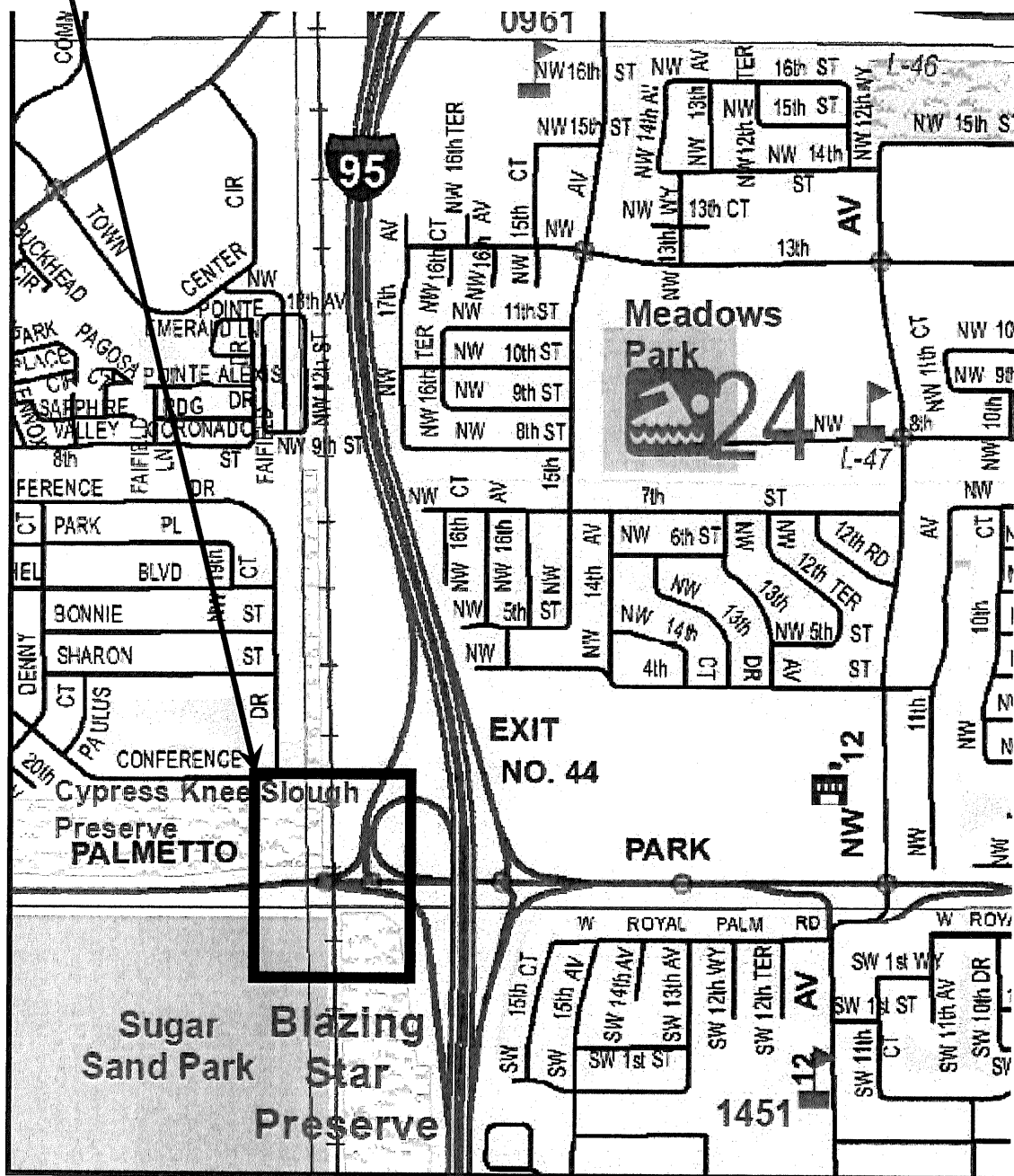

LOCATION SKETCH

RESOLUTION NO. R-2017 _____

RESOLUTION OF THE BOARD OF COUNTY COMMISSIONERS OF PALM BEACH COUNTY, FLORIDA AUTHORIZING EXECUTION OF A RAILROAD REIMBURSEMENT AGREEMENT WITH THE FLORIDA DEPARTMENT OF TRANSPORTATION AND THE SOUTH FLORIDA REGIONAL TRANSPORTATION AUTHORITY FOR SAFETY IMPROVEMENTS AT THE PALMETTO PARK ROAD RAILROAD CROSSING

WHEREAS, the Florida Department of Transportation (FDOT) and the South Florida Regional Transportation Authority (SFRTA) are installing an upgrade of the railroad grade crossing traffic control devices at the SFRTA crossing on Palmetto Park Road DOT/AAR Crossing Number 628165L; and

WHEREAS, FDOT will fund the safety improvements project designated as Financial Project Number 438881-1-57-01 of Palmetto Park Road at SFRTA railroad crossing in Palm Beach County, Florida and

WHEREAS, the SFRTA will construct the safety improvements; and

WHEREAS, Palm Beach County will continue to fund 50% of the annual signal maintenance fees, which is currently \$2,260.

NOW, THEREFORE, BE IT RESOLVED BY THE BOARD OF COUNTY COMMISSIONERS OF PALM BEACH COUNTY FLORIDA, THAT:

Palm Beach County enter into a railroad reimbursement agreement with FDOT and SFRTA for the funding, construction and maintenance of the safety improvements; and

The Mayor of the Board of County Commissioners be authorized to enter into such agreement with FDOT and SFRTA, as herein described; and

This RESOLUTION shall take effect immediately upon adoption.

RESOLUTION NO. R-2017-
_____, 2017

The foregoing Resolution was offered by Commissioner _____ who moved its adoption. The motion was seconded by Commissioner _____, and upon being put to a vote, the vote was as follows:

District 2:	Paulette Burdick, Mayor	_____
District 6:	Melissa McKinlay, Vice Mayor	_____
District 1:	Hal Valeche	_____
District 3:	Dave Kerner	_____
District 4:	Steven L. Abrams	_____
District 5:	Mary Lou Berger	_____
District 7:	Mack Bernard	_____

The Mayor thereupon declared the Resolution duly passed and adopted this ___ day of _____, 20__.

PALM BEACH COUNTY, FLORIDA, BY ITS
BOARD OF COUNTY COMMISSIONERS

ATTEST:

SHARON R. BOCK
CLERK & COMPTROLLER

BY: _____
Deputy Clerk

S E A L

APPROVED AS TO FORM
AND LEGAL SUFFICIENCY

By: _____
(County Attorney)

**STATE OF FLORIDA DEPARTMENT OF TRANSPORTATION
RAILROAD REIMBURSEMENT AGREEMENT
GRADE CROSSING AND CROSSING TRAFFIC CONTROL DEVICES
SOUTH FLORIDA RAIL CORRIDOR ONLY
COUNTY ROADS RR CROSSINGS ONLY**

Financial Project I.D.	Road Name or Number	County Name	Parcel & R/W Number	FAP Number
438881-1-57-01	CR-798/W Palmetto Park Rd	Palm Beach	2(93540-2604)	00S4 052 J

THIS AGREEMENT, made and entered into this _____ day of _____, _____ by and between the **STATE OF FLORIDA DEPARTMENT OF TRANSPORTATION**, hereinafter called the **DEPARTMENT**, and Palm Beach County, a political subdivision of the State of Florida, acting by and through its Board of County Commissioners, hereinafter called the **COUNTY**, and the **SOUTH FLORIDA REGIONAL TRANSPORTATION AUTHORITY**, a body politic and corporate and an agency of the State of Florida created pursuant to Chapter 343, Florida Statutes, hereinafter called the **SFRTA**.

WITNESSETH:

WHEREAS, the **DEPARTMENT** and CSX Transportation, Inc., ("**CSXT**") entered into a contract for Installment Sale and Purchase, for the South Florida Rail Corridor ("**SFRC**") dated May 11, 1988, at which time the **DEPARTMENT** became the owner of said property and **CSXT** retained an exclusive perpetual easement for Rail Freight Operations within the **SFRC** upon which railroad freight, intercity passenger and commuter rail services are currently being conducted, and

WHEREAS, the **DEPARTMENT** and **CSXT** entered into an Operating and Management Agreement Phase A (OMAPA) pertaining to the line of railroad between West Palm Beach and Miami, Florida and related properties on May 11, 1988 (the "Phase A Agreement"), pursuant to which **CSXT** managed and maintained the **SFRC** property on behalf of the **DEPARTMENT** until March 28th, 2015, and

WHEREAS, the **DEPARTMENT** and **CSXT** entered into an Amended South Florida Operating and Management Agreement on January 25, 2013, as may be further amended, which provides for termination of OMAPA and transition of management, operation, and maintenance of the **SFRC** from **CSXT** to the **DEPARTMENT** upon the date determined pursuant to subsection 1(c) of SFOMA (the "SFOMA Commencement Date", which was March 29th, 2015), and

WHEREAS, the **DEPARTMENT** and the **SFRTA** entered into the **SFRC** Operating Agreement ("Operating Agreement") on June 13, 2013, by which the **SFRTA** on behalf of the **DEPARTMENT**, has been managing,

operating, maintaining, and dispatching, railroad operations on the SFRC as of Commencement, and also maintains and repairs the rights-of-way, layover facilities and yards, state-owned buildings and facilities, tracks, bridges, communications, signals and all appurtenances on the SFRC, and

WHEREAS, the **SFRTA**, at the request and sole cost and expense of the **COUNTY** is, constructing, reconstructing or otherwise changing a portion of the Public Road System, designated by **COUNTY** Project number **FM 438881-1-57-01**, on **CR-798 W Palmetto Park Road** which crosses at grade the right-of-way and track(s) of the SFRC at milepost **SX 995.95**, FDOT/AAR Crossing Number **628165L**, at or near **Boca Raton**, Florida as shown on the Project Plan Sheet No. **N/A**, ("Project") attached hereto and made a part hereof, and

WHEREAS, the **COUNTY** is not a party to any of the aforementioned agreements and now agrees to enter into this Railroad Reimbursement Agreement ("Agreement") with **DEPARTMENT**,

NOW, THEREFORE, in consideration of the mutual undertakings as set forth herein, the Parties hereto agree as follows:

1. The **COUNTY** has requested at its sole cost and expense that **SFRTA** construct or reconstruct an at-grade railroad crossing, and necessary approaches thereto, within the **DEPARTMENT's** right-of-way along the SFRC, over its tracks at the above-referenced location.

2. If crossing surface work is required for the Project, the **SFRTA**, shall provide, furnish or have furnished, all necessary material required for, and will construct at **COUNTY's** expense a Standard Railroad Crossing Type _____ in accordance with the **DEPARTMENT's** Standard Index No. 560 attached hereto and by this reference made a part hereof, and in accordance with all other Federal Railroad Administration (FRA) and American Railway Engineering and Maintenance of Way Association (AREMA) standards and guidelines. The initial construction cost and the cost of any reconstruction or rehabilitation thereafter shall be paid by the **COUNTY**. Upon completion of the crossing, the **SFRTA** shall be responsible for the routine maintenance of all trackbed and rail components plus the highway roadbed and surface for the width of the rail ties within the crossing area for single-track crossings, and for all trackbed and rail components plus the highway roadbed and surface for the width of the rail ties within the crossing area and between tracks for multiple-track crossings, in accordance with the Operating Agreement and the SFOMA Agreement. Routine maintenance includes but is not limited to regular track inspections and any repairs to the concrete panels or asphalt within the area described as **SFRTA's** responsibility. The **COUNTY** shall be responsible for the maintenance of the highway roadbed and surface outside the railway ties. IT BEING

EXPRESSLY UNDERSTOOD AND AGREED that if the **COUNTY** does not properly maintain the highway roadbed and surface outside the railroad ties, the **SFRTA** may, at its option and upon notification to the **COUNTY**, perform such maintenance work and bill the **COUNTY** directly for costs thus incurred. All costs required for any subsequent reconstruction or rehabilitation of the crossing, as may be requested by any of the Parties to this Agreement, shall be the sole financial responsibility of the **COUNTY**.

If Railroad Grade Crossing Traffic Control Devices work is required for the Project, the **SFRTA**, shall provide, furnish or have furnished, all necessary material required for, and will install at the **COUNTY**'s expense automatic, railroad grade crossing traffic control devices at said location in accordance with the **DEPARTMENT**'s Plans and Standard Index Number 17882 attached hereto, and by this reference made a part hereof. If traffic control devices are being installed/upgraded under the Signal Safety Program (US Code Title 23, Section 130), then the **DEPARTMENT** will reimburse **SFRTA** for 100% of the costs of installation/upgrades pursuant to the Operating Agreement and the SFOMA Agreement.

3. The cost of maintaining all signals at the crossing shall be allocated as follows; fifty percent (50%) of the expense thereof in maintaining the same shall be borne by the **COUNTY**, and fifty percent (50%) of the cost shall be borne by the **SFRTA**, as enumerated by the Schedule of Annual Cost of Automatic Highway Grade Crossing Traffic Control Devices attached hereto and by this reference made a part hereof and subject to future revision. Actual funding for the signals has been provided for in the Operating Agreement. **COUNTY** shall submit its 50% of the cost of the Annual Maintenance costs to the **DEPARTMENT**. In instances where signals are installed and/or adjusted pursuant to this Agreement and found to be in satisfactory working order by the Parties hereto, the same shall be immediately put in service, operated and maintained by the **SFRTA** pursuant to the Operating Agreement and the SFOMA Agreement so long as **SFRTA** or successors or assigns shall operate the said signals at said grade crossing; or until it is agreed between the Parties hereto that the signals are no longer necessary; or until the said crossing is abandoned; or legal requirements occur which shall cease operation of those signals. The **SFRTA** agrees that any future relocation or adjustment of said signals shall be performed by the **SFRTA**, but at the expense of the party initiating such relocation. Upon relocation, the maintenance responsibility shall be in accordance with the provisions of this Agreement. It is further agreed that the cost of maintaining any additional or replacement signal equipment at the same location will be shared as provided above.

4. Unless otherwise agreed upon herein, the **COUNTY** agrees to ensure that the advance warning signs and railroad crossing pavement markings will conform to the Department of Transportation Manual on Uniform Traffic Control Devices (MUTCD) within 30 days of notification that the railroad signal improvements have been completed and that such signs and pavement markings will be continually maintained in conformance with the MUTCD as applicable.
5. The **DEPARTMENT** at its discretion, may arrange for the synchronization of the railroad crossing devices with existing or proposed highway traffic control devices at **CR-798 W Palmetto Park Road**. Neither of the Parties shall disconnect the interconnection circuit or change or cause to be changed the signal sequence without prior notice to the other parties. Each party shall maintain its respective devices from the point of the junction box as provided for the interconnect cable.
6. All work contemplated at this crossing shall at all times be subject to the approvals and notice provisions of the **Operating Agreement** and the **SFOMA Agreement**.
7. The **COUNTY** will reimburse **SFRTA** for the cost of watchmen or flagging service in the carrying out of work adjacent to the **SFRC**, or work requiring movement of equipment, employees or trucks across the **SFRC**, or when at times **SFRTA** and/or the **DEPARTMENT** agree that such a service is necessary.
8. All contractors working in the SFRC are required to have Railroad Protective Public Liability and Railroad Protective Property Damage Liability insurance where the **DEPARTMENT**, **SFRTA**, and **CSXT** are named insureds, and with limits not less than **\$ 2,000,000.00** combined single limit for bodily injury and/or property damage per occurrence and with an annual aggregate limit of no less than **\$ 6,000,000.00** Contractor will furnish the **DEPARTMENT** and **SFRTA** a Certificate of Insurance showing that the contractor carries liability insurance (applicable to the job in question) in the amounts set forth above. Such insurance is to conform with the requirements of the U.S. Department of Transportation, Federal Highway Administration, Federal Aid Policy Guide, Subchapter G, Part 646, Subpart A, and any supplements thereto or revisions thereof.
9. **SFRTA** hereby agrees, as applicable, to install and/or adjust the necessary parts of the SFRC facilities in accordance with the provisions set forth in the:

- (A) **DEPARTMENT** Procedure 725-080-002 Appendix D.4 and Rule 14-57.011 "Public Railroad-Highway Grade Crossing Costs", Florida Administrative Code,

- (B) Federal Highway Administration's Federal Aid-Highway Policy Guide, 23 C.F.R. Subchapter B, Part 140, Subpart I; and 23 C.F.R. Subchapter G, Part 646, Subpart B,

and any supplements thereto or revisions thereof, which, by reference hereto, are made a part hereof. **SFRTA** further agrees to do all such work with its own forces or by a contractor paid under a contract held by **SFRTA** under the supervision and approval of the **DEPARTMENT**, and the Federal Highway Administration, when applicable.

10. The **COUNTY** hereby agrees to reimburse **SFRTA**, as detailed in this Agreement, for all costs incurred by it in the installation and/or adjustment of said facilities, in accordance with the provisions above. If the Project is for Signal Safety improvements under Title 23, Section 130, then the **DEPARTMENT** agrees to reimburse **SFRTA**, as detailed in this Agreement, for all costs incurred by it in the installation and/or adjustment of said facilities, in accordance with the provisions above. It is understood and agreed by and between the Parties hereto that preliminary engineering costs not incorporated within this Agreement shall be subject to payment by the **COUNTY**.
11. Attached hereto, and by this reference made a part hereof, are plans and specifications of the work to be performed by **SFRTA** pursuant to the terms hereof, and an estimate of the costs thereof in the amount of \$35,499.00. All work performed by the **SFRTA** pursuant hereto, shall be performed according to these plans and specifications as approved by the **DEPARTMENT**, and the Federal Highway Administration, if federal aid participating; and all subsequent plan changes shall likewise be approved by the **DEPARTMENT** and the Federal Highway Administration, when applicable.
12. All labor, services, materials, and equipment furnished by **SFRTA** in carrying out work to be performed, shall be billed by **SFRTA** directly to the **COUNTY**. If the Project is for Signal Safety improvements under Title 23, Section 130, then all labor, services, materials, and equipment furnished by **SFRTA** in carrying out work to be performed, shall be billed by **SFRTA** directly to the **DEPARTMENT**. Separate records as to costs of contract bid terms and force account items performed by **SFRTA** shall also be furnished by **SFRTA** to the **DEPARTMENT**.
13. The **DEPARTMENT** has determined that the method to be used by the **SFRTA** in developing future relocation or installation cost shall be actual and related indirect costs accumulated in

accordance with a work order accounting procedure prescribed by the applicable Federal or State regulatory body.

14. It is specifically agreed by and between the **DEPARTMENT**, the **COUNTY** and the **SFRTA**, that the **DEPARTMENT** and/or the **COUNTY** shall receive fair and adequate credit for any salvage which shall accrue to the **SFRTA** as a result of the above adjustment work.
15. Upon completion of the work, the **SFRTA** shall, within one hundred eighty (180) days, furnish the **COUNTY** with three (3) copies of its final and complete billing of all costs incurred in connection with the work performed hereunder, such statement to follow as closely as possible the order of items contained in the estimate attached hereto. The **COUNTY** shall reimburse the **SFRTA** for its portion of all actual costs attributable to the Project subject to other provisions in this Agreement. The total for labor, overhead, travel expenses, transportation, equipment, material and supplies, handling costs, and other services shall be shown in such a manner as will permit ready comparison with the approved plans and estimates. Material shall be itemized where they represent major components of cost in the relocation following the pattern set out in the approved estimate as closely as possible. Salvage credits from recovered and replaced permanent and recovered temporary materials shall be reported in said bills in relative position with the charge for the replacement or the original charge for temporary use.

The final billing shall show the description and site of the Project; the date on which the first work was performed, or, if preliminary engineering or right-of-way items are involved, the date on which the earliest item of billed expenses was incurred; the date on which the last work was performed or the last item of billed expenses was incurred; and the location where the records and accounts billed can be audited. Adequate reference shall be made in the billing to the **SFRTA**'s records, accounts, and other relevant documents. All cost records and accounts shall be subject to audit by a representative of the **COUNTY**. Upon receipt of invoices, prepared in accordance with the above reimbursement provisions, the **COUNTY** agrees to reimburse the **SFRTA** in the amount of such actual costs approved by the **COUNTY**'s auditor.

For Signal Safety Projects under the Rail/Highway Grade Crossing Safety Improvement Program; the cost therefore shall be governed and reimbursed in accordance with Paragraphs 16 through 23 below.

16. Upon completion of the work, the **SFRTA** shall, within one hundred eighty (180) days, furnish the **DEPARTMENT** with three (3) copies of its final and complete billing of all costs incurred in

connection with the work performed hereunder, such statement to follow as closely as possible the order of items contained in the estimate attached hereto. The **DEPARTMENT** shall reimburse the **SFRTA** for its portion of all actual costs attributable to the Project subject to other provisions in this Agreement. The total for labor, overhead, travel expenses, transportation, equipment, material and supplies, handling costs, and other services shall be shown in such a manner as will permit ready comparison with the approved plans and estimates. Material shall be itemized where they represent major components of cost in the relocation following the pattern set out in the approved estimate as closely as possible. Salvage credits from recovered and replaced permanent and recovered temporary materials shall be reported in said bills in relative position with the charge for the replacement or the original charge for temporary use.

The final billing shall show the description and site of the Project; the date on which the first work was performed, or, if preliminary engineering or right-of-way items are involved, the date on which the earliest item of billed expenses was incurred; the date on which the last work was performed or the last item of billed expenses was incurred; and the location where the records and accounts billed can be audited. Adequate reference shall be made in the billing to the **SFRTA's** records, accounts, and other relevant documents. All cost records and accounts shall be subject to audit by a representative of the **DEPARTMENT**. Upon receipt of invoices, prepared in accordance with the above reimbursement provisions, the **DEPARTMENT** agrees to reimburse the **SFRTA** in the amount of such actual costs approved by the **DEPARTMENT's** auditor.

17. In accordance with Section 215.422 Florida Statutes, the following provisions are in this Agreement:

Contractors providing goods and services to the **DEPARTMENT** should be aware of the following time frames. Upon receipt, the **DEPARTMENT** has five (5) working days to inspect and approve the goods and services, unless the Agreement specifies otherwise. The **DEPARTMENT** has twenty (20) working days to deliver a request for payment (voucher) to the Department of Banking and Finance. The twenty (20) days are measured from the latter of the date the invoice is received or the date the goods or services are received, inspected, and approved.

If a payment is not available, within forty (40) days, a separate interest penalty at a rate as established pursuant to Section 215.422 (3)(b), Florida Statutes, will be due and payable in addition to the invoice amount, to the Contractor. Interest penalties of less than one (1) dollar will not be enforced unless the Contractor requests payment. Invoices, which have to be returned to a Contractor because of Contractor preparation errors, will result in a delay in the payment. The

invoice payment requirements do not start until a properly completed invoice is provided to the **DEPARTMENT**.

A Vendor Ombudsman has been established within the Department of Bank and Finance. The duties of the individual include acting as an advocate for contractors/vendors who may be experiencing problems in obtaining timely payment(s) from a state agency. The Vendor Ombudsman may be contacted at (850) 413-5516, or by calling the Division of Consumer Services at 1-877-693-5236.

18. Payment shall be made only after receipt and approval of goods and services unless advance payments are authorized by the **DEPARTMENT**'s Comptroller under Section 334.44(29), F.S., or by the Department of Financial Services under Section 215.422(14), F.S.
19. In accordance with Section 287.058 F.S., the following provisions are in this Agreement: If this contract involves units of deliverables, then such units must be received and accepted in writing by the Contract Manager prior to payments. Bills for fees or other compensation for services or expenses shall be submitted in detail sufficient for a proper pre-audit and post-audit thereof.
20. Bills for travel expenses specifically authorized in this Agreement shall be submitted and paid in accordance with **DEPARTMENT** Rule 14-57.011, Florida Administrative Code, and the Federal Highway Administration Federal Aid Policy Guide, 23 C.F.R. Subchapter B, Part 140, Subpart I "Reimbursement for Railroad Work."
21. In the event this contract is for services in excess of TWENTY-FIVE THOUSAND DOLLARS (\$25,000.00) and a term of more than one year, the provisions of Section 339.135 (6)(a), Florida Statutes are hereby incorporated;

The **DEPARTMENT** during any fiscal year, shall not expend money, incur any liability, or enter into any contract which, by its terms, involves the expenditures of money in excess of the amounts budgeted as available for expenditure during such fiscal year. Any contract, verbal or written, made in violation of this subsection is null and void, and no money may be paid on such contract. The **DEPARTMENT** shall require a statement from the Comptroller of the **DEPARTMENT** that such funds are available prior to the entering into any such contract or other binding commitment of funds.

Nothing herein contained shall prevent the making of contracts for periods, exceeding one year, but any contract so made shall be executory only for the value of the services to be rendered or agreed to be paid for in succeeding fiscal years, and this paragraph shall be incorporated verbatim in all contracts of the **DEPARTMENT** which are for an amount in excess of TWENTY-FIVE THOUSAND DOLLARS (\$25,000.00) and which have a term for a period of more than one year.

22. In accordance with Section 287.133 (2)(a), Florida Statutes, the following provisions are included in this Agreement:

A person or affiliate who has been placed on the convicted vendor list following a conviction for a public entity crime may not submit a bid on a contract to provide any goods or services to a public entity, may not submit a bid on a contract with a public entity for the construction or repair of a public building or public work, may not submit bids, proposals, or replies on leases for real property to a public entity; may not be awarded or perform work as a contractor, supplier, subcontractor, or consultant under a contract with any public entity; and may not transact business with any public entity in excess of the threshold amount provided in section 287.017 for CATEGORY TWO for a period of 36 months from the date of being placed on the convicted vendor list.

23. In accordance with Section 287.134(2)(a), Florida Statutes, the following provisions are included in this agreement:

An entity or affiliate who has been placed on the discriminatory vendor list may not submit a bid, proposal, or reply on a contract to provide any goods or services to a public entity; may not submit a bid, proposal, or reply on a contract with a public entity for the construction or repair of a public building or public work; may not submit bids, proposals, or replies on leases of real property to a public entity; may not be awarded or perform work as a contractor, supplier, subcontractor, or consultant under a contract with any public entity; and may not transact business with any public entity.

24. The **DEPARTMENT's** obligation to pay under this contract is contingent upon an annual appropriation by the Florida Legislature in accordance with Section 287.0582, Florida Statutes.

25. The **SFRTA** shall allow public access to all documents, papers, letters, or other material subject to the provisions of Chapter 119, Florida Statutes, and made or received by the **SFRTA** in conjunction with this Agreement. Specifically, if the **SFRTA** is acting on behalf of a public agency the **SFRTA** shall:

- (a) Keep and maintain public records that ordinarily and necessarily would be required by the **DEPARTMENT** in order to perform the services being performed by the **SFRTA**.
- (b) Provide the public with access to public records on the same terms and conditions that the **DEPARTMENT** would provide the records and at a cost that does not exceed the cost provided in Chapter 119, Florida Statutes, or as otherwise provided by law.
- (c) Ensure that public records that are exempt or confidential and exempt from public records disclosure requirements are not disclosed except as authorized by law.
- (d) Meet all requirements for retaining public records and transfer, at no cost, to the **DEPARTMENT** all public records in possession of the **SFRTA** upon termination of the contract and destroy any duplicate public records that are exempt or confidential and exempt from public records disclosure requirements. All records stored electronically must be provided to the **DEPARTMENT** in a format that is compatible with the information technology systems of the **DEPARTMENT**.

Failure by the **SFRTA** to grant such public access shall be grounds for immediate unilateral cancellation of this Agreement by the **DEPARTMENT**. The **SFRTA** shall promptly provide the **DEPARTMENT** with a copy of any request to inspect or copy public records in possession of the **SFRTA** and shall promptly provide the **DEPARTMENT** a copy of the **SFRTA's** response to each such request.

- 26. Should the use of said crossing be abandoned due to removal of the roadway then all rights hereby granted to the **COUNTY** shall thereupon cease and terminate and the **COUNTY** will, at its sole cost and in a manner satisfactory to the **SFRTA** and the **DEPARTMENT**, remove said crossing and restore the **SFRC** property to the condition previously found, provided that the **SFRTA** may, at its option, remove the said crossing and restore its property, and the **COUNTY** will, in such event, upon bill rendered, pay to the **SFRTA** the entire cost incurred by it in such removal and restoration, provided such costs are accrued as specified in Paragraph 9.
- 27. Liability for services performed under this agreement shall be governed in accordance with the terms and conditions of the Operating Agreement.
- 28. Upon execution, this Agreement shall supersede all provisions, relating to said crossing contained in any previous agreements and shall become the permanent agreement of record.

29. **SFRTA** shall:
1. Utilize the U.S. Department of Homeland Security's E-Verify system to verify the employment eligibility of all new employees hired by the **SFRTA** during the term of the contract; and
 2. Expressly require any subcontractors performing work or providing services pursuant to the state contract to likewise utilize the U.S. Department of Homeland Security's E-Verify system to verify the employment eligibility of all new employees hired by the subcontractor during the contract term.
30. It is understood and agreed by the Parties to this Agreement that if any part, term, or provision of this Agreement is held illegal by the courts or in conflict with any law of the State of Florida, the validity of the remaining portions or provisions shall not be affected, and the rights and obligations of the Parties shall be construed and enforced as if the Agreement did not contain the particular part, term, or provision held to be invalid.
31. Any questions or matters arising under this Agreement as to validity, construction, enforcement, performance, or otherwise, shall be determined in accordance with the laws of the State of Florida. Venue for any action arising out of or in any way related to this Agreement shall lie exclusively in a state court of appropriate jurisdiction.
32. The Parties agree to bear their own attorney's fees and costs with respect to this Agreement.
33. The Parties agree that this Agreement is binding on the Parties, their heirs-at-law, and their assigns and successors in interest as evidenced by their signatures and lawful executions below.
34. A modification or waiver of any of the provisions of this Agreement shall be effective only if made in writing and executed with the same formality as this Agreement.
35. If the Operating Agreement between the **DEPARTMENT** and the **SFRTA** ceases to exist, the responsibilities of **SFRTA** may be assigned to a party operating the railroad.

IN WITNESS WHEREOF, the parties hereto have caused this Agreement to be executed by their respective and duly authorized officers the day and year first written above.

SFRTA

South Florida Regional Transportation Authority, A body politic and corporate and an agency of the State of Florida

By: _____
SFRTA Executive Director

Date: _____

Approved as to form and legal sufficiency

By: _____
SFRTA General Counsel

DEPARTMENT

State of Florida, Department of Transportation,
An Agency of the State of Florida

By: _____
Director of Transportation Development

Date: _____

Legal Review (DEPARTMENT):

By: _____

COUNTY

Attest:

**SHARON R. BOCK
CLERK & COMPTROLLER**

By: _____
Deputy Clerk

**PALM BEACH COUNTY
BOARD OF COUNTY COMMISSIONERS**

By: _____
Mayor – Paulette Burdick

Date: _____

**APPROVED AS TO FORM
AND LEGAL SUFFICIENCY**

By: _____
County Attorney

**APPROVED AS TO TERMS
AND CONDITIONS**

By: *Orlando G. Fernandez*
Department Director

AS

STATE OF FLORIDA DEPARTMENT OF TRANSPORTATION
WORK DESCRIPTION
GRADE CROSSING TRAFFIC CONTROL DEVICES

725-090-09
RAIL
05/02

FINANCIAL PROJECT NO.	ROAD NAME OR NUMBER	COUNTY NAME	PARCEL & R/W NUMBER	FAP NUMBER
43888115701	CR-798/W Palmetto	PALM BEACH	2(93540-2604)	00S4 052 J

RAILROAD COMPANY

South Florida Regional Transportation Authority

- A. JOB DESCRIPTION & LOCATION: Install 1 MDAII w/DTMF, 4 Gate Savers, Design and AIS
- B. TYPE OF ROADWAY FACILITY: 6 thru lanes and 4 auxiliary/turn lanes
- C. FDOT/AAR XING NO.: 628165L RR MILE POST TIE: SX 995.95
- D. TYPE CROSSING PROPOSED: IV CLASS: IV DOT INDEX NO.: 17882
- E. STATUS AND PROPOSAL:

1. EXISTING DEVICES: (See Agreement dated _____)
- a. _____ None-New Crossing.
 - b. _____ Crossbuck and Disk.
 - c. _____ Flashing Signals with Disk.
 - d. _____ Flashing Signals with Cantilever.
 - e. _____ Flashing Signals with Gates.
 - f. XX Flashing Signals with Cantilever and Gates.

2. PROPOSED DEVICES: (Safety Index Rating 11)
- a. _____ No revision required.
 - b. _____ Crossbuck and Disk.
 - c. _____ Flashing Signals and Disk.
 - d. _____ Flashing Signals with Cantilever.
 - e. _____ Flashing Signals with Gates.
 - f. XX Flashing Signals with Cantilever and Gates.
 - g. _____ Relocate existing signal devices:
 - (1) _____ (With-Without) addition of Gates.
 - (2) _____ (With-Without) synchronization with highway traffic signals.
 - (3) _____ (With-Without) constant warning time.

- F. COMMUNICATION AND/OR POWER LINE ADJUSTMENTS
- 1. N/A By Others (_____ Company.)
 - 2. N/A By Railroad Company.

- G. AUTHORITY REQUESTED: (Draft attached: Yes No.)
- 1. XX Agreement (Third Party Participating _____)
 - 2. _____ Supplemental Agreement No. _____
 - 3. _____ Crossing Permit. _____
 - 4. _____ Estimate for Change Order No. _____
 - 5. _____ Letter of Authority.
 - 6. _____ Letter of Confirmation (No Cost to Department).

H. OTHER REMARKS:

Negotiations to be completed by: _____
Signal installation target date: _____
Synchronization: (Draft attached Yes No.)

STATE OF FLORIDA DEPARTMENT OF TRANSPORTATION
**RAILROAD GRADE CROSSING TRAFFIC CONTROL DEVICES
 ANNUAL MAINTENANCE COSTS**

725-090-41
 RAIL
 OGC - 07/16

FINANCIAL PROJECT NO.	ROAD NAME OR NUMBER	COUNTY NAME	PARCEL & R/W NUMBER	FAP NUMBER
43888115701	CR-798/W Palmetto	PALM BEACH	2(93540-2604)	00S4 052 J

COMPANY NAME: South Florida Regional Transportation Authority

A. FDOT/AAR XING NO.: 628165L RR MILE POST TIE: SX 995.95

B. TYPE SIGNALS PROPOSED IV CLASS IV DOT INDEX: 17882

**SCHEDULE OF ANNUAL COST OF AUTOMATIC
 HIGHWAY GRADE CROSSING TRAFFIC CONTROL DEVICES**

Annual Maintenance Cost Exclusive of Installation

<u>CLASS</u>	<u>DESCRIPTION</u>	<u>COST*</u>
I	2-Quadrant Flashing Lights with One Track	\$2,386.00
II	2-Quadrant Flashing Lights with Multiple Tracks	\$3,158.00
III	2-Quadrant Flashing Lights and Gates with One Track	\$3,600.00
IV	2-Quadrant Flashing Lights and Gates with Multiple Tracks	\$4,520.00
V	3 or 4-Quadrant Flashing Lights and Gates with One Track	\$7,116.00
VI	3 or 4-Quadrant Flashing Lights and Gates with Multiple Tracks	\$8,930.00

AUTHORITY: FLORIDA ADMINISTRATIVE RULE 14-57.011
 Public Railroad-Highway Grade Crossing Costs

EFFECTIVE DATE: July 22, 1982

GENERAL AUTHORITY: 334.044, F.S.

SPECIFIC LAW IMPLEMENTED: 335.141, F.S.

*This schedule will become effective July 1, 2016 and will be reviewed every 5 years and revised as appropriate based on the Consumer Price Index for all Urban Consumers published by the U.S. Department of Labor.

STATE OF FLORIDA
DEPARTMENT OF TRANSPORTATION

OFFICE OF MODAL DEVELOPMENT
DISTRICT 4 RAIL OFFICE

PROJECT SCOPE AND COST ESTIMATE

PROJECT INFORMATION

Financial Project No.: 438881-1-57-01
FAP Number: 00S4-052 J
Location: CR-798/W. Palmetto Park Rd
County: Palm Beach
Crossing No.: 628165-L
RR. MP.: SX 995.95
Company: South Florida Regional Transportation Authority

*This project scope and cost estimate was prepared by: District 4 Railroad
Coordinator's Office*

MDAII Event Recorder with DTMF Module, 4 Gate Servers, Installation,
Engineering Inspection and Labor..... \$ 35,498.80

TOTAL ESTIMATED COSTS.....\$ 35,498.80

VTMI



CONTRACT AMENDMENT NO.

Contract No. 14-012
Amendment No. TBD
Project: Maintenance of Way ("MOW") Services
Contractor: VTMI
Contractor Ref No.: 079

The following changes are hereby authorized to be performed by the Contractor, for the stipulated cost and/or time extension herein, upon the signatures below by SFRTA.

Description of Changes, Reasons Therefore, and Cost and/or Time Extension for Each:

SFRTA requires the services of VTMI to perform signal safety upgrades to the grade crossing on Palmetto Park Rd in Palm Beach County which have been requested by FDOT and the City of Boca Raton. VTMI shall provide all necessary labor, equipment, materials, hardware design, construction, and in-services testing for the following signal safety upgrades to grade crossing (628165L) Palmetto Park Rd:

1. Install 1 ea. MDAII w/DTMF
2. Install 4 ea. Gate Savers
3. Design and AIS

Change:

- A. VTMI shall perform a survey of the jobsite
- B. VTMI shall procure all materials necessary for the installation of the signal safety upgrades and shall deliver all material to the jobsite.
- C. VTMI shall remove and dispose of and/or salvage the existing upgraded signal material.

Reason for change: FDOT has requested SFRTA have this work performed.

Cost of Change: Total - \$35,498.80

Time Extension for change: N/A - Within Contract Timeframe

TOTAL **\$35,498.80**

The following changes are hereby authorized to be performed by the Contractor, for the stipulated cost and/or time extension herein, upon the signature below by the representatives of SFRTA.

It is agreed that this Amendment shall not alter or change in any manner the force and effect of the Contract Documents, including any previous amendments thereto, except insofar as the same is altered and amended by this Amendment.

SFRTA and the Contractor agree that the Contract time adjustment and the sum agreed to in this Amendment constitutes a full and complete settlement of all the matters set forth herein, including all direct cost for equipment, manpower, materials, overhead, profit, and delay relating to the issues set forth in the Amendment. Furthermore, the Contractor accepts the terms of this Amendment as related to cost determinations as full compensation for all costs of equipment, manpower, materials, overhead, profit and delay damages and for all their costs. This settlement is limited to and applies to any claims arising out of or on account of the matters described and set forth in this Amendment.

Accepted by Procurement:

Signature: _____
Name and Title: _____
Date: _____

Accepted by Project Manager:

Signature: _____
Name and Title: _____
Date: _____

Accepted by Contractor:

Signature: 
Name and Title: N Blaize Agm
Date: 9/14/14

Approved by SFRTA Executive Director:

Signature: _____
Name and Title: _____
Date: _____

Approved as to form and legal sufficiency:

Signature: _____
Name and Title: _____
Date: _____



Estimated Cost for Extra Work #079

Palmetto Park Rd Signal Safety Upgrades X-ing 628165L



Extra Work	079
Name	Palmetto Park Rd Signal Safety Upgrade:
Date	9/13/2016

Estimator Name	Brian Goss
Estimator E-mail	marcus.goss@transdev.com
Estimator Phone	(770) 480 3120

1. Scope of Work

Supply the necessary hardware design, materials, construction, and in-service testing for the following:

- Installation of 1 MDA II with DTMF
- Installation of 4 Gate Savers
- Design & As-In-Service

Estimate will be billed Time & Material

Prices may not be valid after 60 days.

Total Cost: \$ 35,498.80



Estimated Cost for Extra Work #079
 Palmetto Park Rd Signal Safety Upgrades X-ing 628165L



2. Cost:

A. Management

I. Labor

Position	Work Hours	FBLC Hourly Rate	Labor Bid Total
Facility Manager	-	46.78	-
Office Manager	4.00	41.30	165.21
Materials Manager	4.00	70.48	281.91
RMIS Technician	-	30.36	-
Safety Manager	-	89.19	-
General Manager	-	107.06	-
Roadmaster	-	65.51	-
Signal Manager	-	65.51	-
Sr. Manager Comm. & Sig.	-	94.01	-
Project Engineer	4.00	63.11	252.44
Communications Manager	-	63.11	-
Project Manager	-	-	-
	-	-	-
Management Labor Total			699.56

II. Vehicle

Description	Hours	Equip. Rate	Equip. Bid Total
Pick-up F150	-	16.80	-
SUV	-	13.23	-
	-	-	-
	-	-	-
Management Equipment Total			-



Estimated Cost for Extra Work #079
 Palmetto Park Rd Signal Safety Upgrades X-ing 628165L



C. Signal

I. Labor

Position	WK HRS RE	WK HRS	HRLY RATE	HRLY RATE	RE TOTAL	OT TOTAL	TOTAL
Signal Maintainer	-	40.00	52.59	72.01	-	2,880.40	2,880.40
Signal Inspector/Comm Tech	-	60.00	63.80	88.82	-	5,329.20	5,329.20
Signalman	-	-	52.59	72.01	-	-	-
Signal Foreman	-	20.00	58.78	81.41	-	1,628.20	1,628.20
	-	-	-	-	-	-	-
Signal Labor Total							9,837.80

II. Equipment

Description	Hours	Equip. Rate	Equip. Bid Total
Signal truck	60.00	\$ 22.07	1,324.20
Signal Hi-Rail vehicle	-	\$ 33.48	-
Hi-Rail boom truck	-	\$ 137.61	-
Bucket Truck	-	\$ 54.48	-
Pick-up 150	60.00	\$ 18.44	1,106.40
	-	-	-
	-	-	-
	-	-	-
Signal Equipment Total			2,430.60

III. Materials

Type	Qty.	UOM	Unit Price	Freight	Cost
LED Crossing Signal One-Way (Gate)		EA	2,306.00		-
LED Crossing Signal One-Way (Main Mast)		EA	2,306.00		-
LED Crossing Signal One-Way (Arm)		EA	2,269.00		-
LED Crossing Signal One-Way (Main Mast Sidelight)		EA	2,355.00		-
LED Crossing Signal Two-Way (Arm)		EA	3,123.00		-
LED Crossing Signal Two-Way (Gate)			3,123.00		-
NAS MDAA II with DTMF	1.00	EA	3,450.00		3,450.00
NEG Gate Saver	4.00		1,555.00		6,220.00
Cable 5/C#9			4.30		-
Siemens Electronic Bell			489.00		-
Crossing Warning Indicator	1.00		1,382.74		1,382.74
Signal Materials Total					11,052.74



Estimated Cost for Extra Work #079
 Palmetto Park Rd Signal Safety Upgrades X-ing 628165L



D. Structures Department

I. Labor

Position	WK HRS RE	WK HRS OT	HRLY RATE RE	HRLY RATE OT	RE TOTAL COST	OT TOTAL COST	TOTAL
Bridge Foreman	-	-	46.70	62.75	-	-	-
Bridge Tender	-	-	45.38	61.20	-	-	-
Bridge Laborer	-	-	42.40	56.31	-	-	-
	-	-	-	-	-	-	-
Structures Labor Total							<u>-</u>

II. Equipment

Description	Hours	Equip. Rate	Equip. Bid Total
Utility Van	-	15.00	-
Pick-up 150	-	11.00	-
	-	-	-
Structures Equipment Total			<u>-</u>

III. Materials

Type	Qty.	UOM	Unit Price	Freight	Cost
					-
					-
					-
					-
					-
					-
					-
Structures Materials Total					<u>-</u>



Estimated Cost for Extra Work #079
 Palmetto Park Rd Signal Safety Upgrades X-ing 628165L



E. Facility

I. Labor

Position	WK HRS RE	WK HRS OT	HRLY RATE RE	HRLY RATE OT	RE TOTAL COST	OT TOTAL COST	TOTAL
Janitor	-	-	35.76	46.34	-	-	-
Carpenter	-	-	39.17	51.46	-	-	-
Electrician	-	-	42.59	56.59	-	-	-
Painter	-	-	35.76	46.34	-	-	-
	-	-	-	-	-	-	-
Facility Labor Total							<u>-</u>

II. Equipment

Description	Hours	Equip. Rate	Equip. Bid Total
Transit Van	-	55.00	-
Paint Sprayer	-	14.00	-
Pick-up 150	-	11.00	-
	-	-	-
Facility Equipment Total			<u>-</u>

III. Materials

Type	Qty.	UOM	Unit Price	Freight	Cost
					-
					-
					-
					-
					-
					-
					-
Facility Materials Total					<u>-</u>



Estimated Cost for Extra Work #079

Palmetto Park Rd. Signal Safety Upgrades X-ing 628165L



F. Sub-Contractors

Name	Description	Price Per	UOM	Unit Price	Sub. Bid Total
Xorail	As-In-Service	1.00	EA	7,500.00	7,500.00
					-
					-
					-
					-
					-
					-
					-
Sub-Contractors Total					7,500.00

G. Mobilization & Demobilization

Type	Detail	Bid Total
Mobe/Demobe Total		-

H. Miscellaneous

Description	Cost	
Miscellaneous Total		-

3. Summary

Type	Cost
Total Labor	10,537.36
Total Equipment	2,430.60
Total Materials	11,052.74
Total Mobilization	-
Total Miscellaneous	-

Subtotal 24,020.70
 15% Markup 3,603.10
Total \$ 27,623.80

Sub Contractor Total 7,500.00
 5% Markup 375.00
Total 7,875.00
 Grand Total **35,498.80**

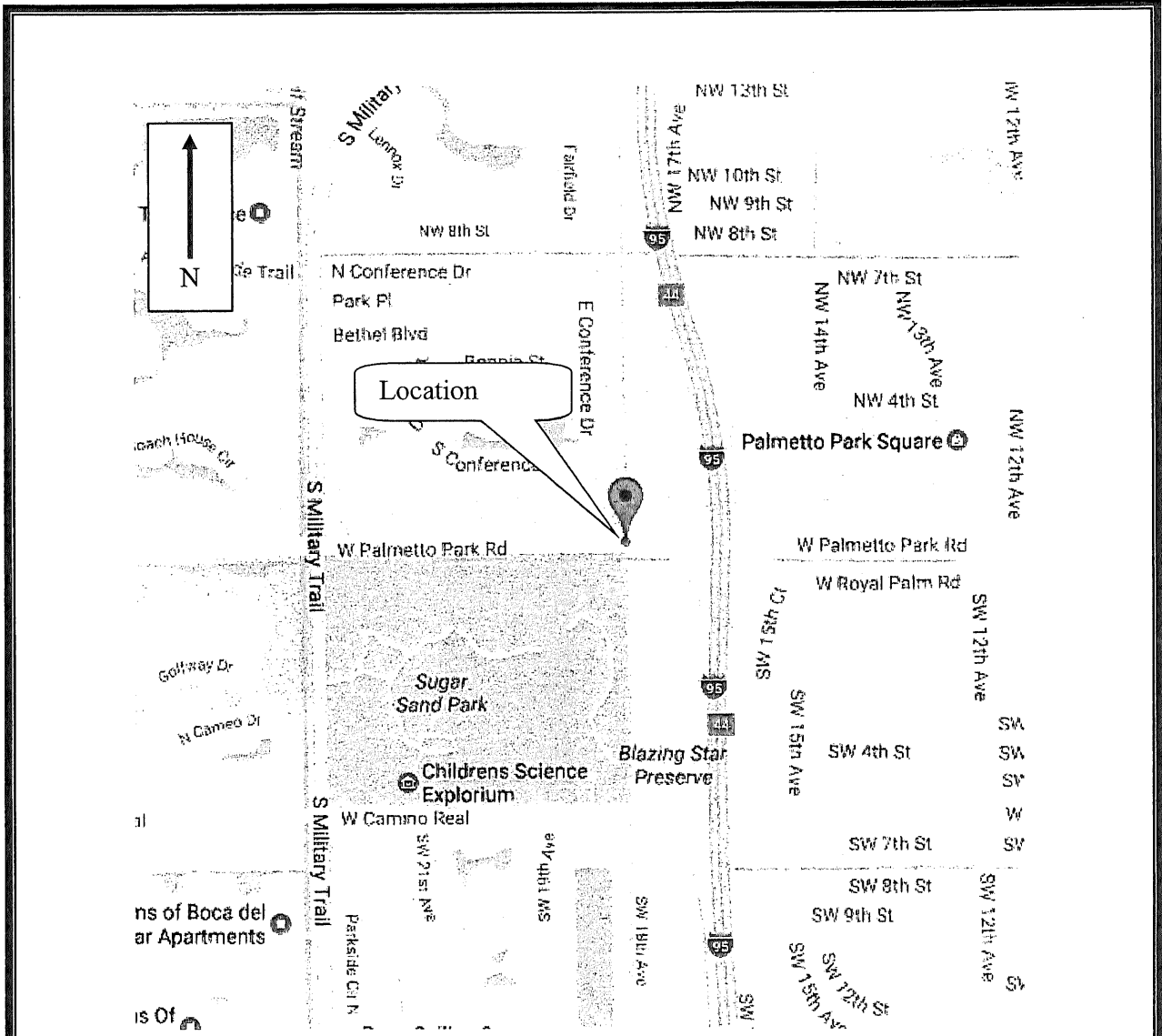

LOCATION MAP

South Florida Regional Transportation Authority

LOCATION:	CR-798/W Palmetto Park, Palm Beach County
FINANCIAL PROJECT NO.:	438881-1-57-01
CROSSING NO.:	628165-L
RAILROAD MILEPOST:	SX 995.95

Crossing No: 628165L Roadway: W PALMETTO PARK RD RR Street: District: 4 County: Palm Beach
 PUBLIC HWY AT GRADE Commercial City: Boca Raton IN CITY OPEN-TRACK ACTIVE

Rank 2016: SR No.: RR Company: SFRV Date: 08/17/2015
 Rank 2015: 11 CR No.: CR 798 Division Name: JACKSONVILLE Team Members: Scott
 Rank 2014: US No.: Subdivision Name: MIAMI Albritton, Maurice Borrows,
 Latitude: 26.350800 Branch Name: SX 810 Alex Barr, Henry Parrish, John
 Longitude: -80.120000 RR Milepost: 995.95 Barragan, Hector Hartmann,
 Field Review Comments: Marco Incer, Michael Hren,
 Nikeisha Thomas.

Team Recommendations: Railroad: Option #1 Event Recorder, Radio Keydown, 4 Gate Savers. Option #2: Option #1
 and replace cantilevers with bridges Roadway: Dynamic Envelope ADA: Detectable Warning Surface on all the
 approaches

Highway Speed:	40	<input type="checkbox"/>	Train Speed Range:	74-79	<input type="checkbox"/>
Crossing Angle:	60-90 DEG	<input type="checkbox"/>	Max Time Table Speed:	79	<input type="checkbox"/>
AADT:	56500 (2012)	<input type="checkbox"/>	Day Thru/Switch:	45/0	<input type="checkbox"/>
Percent Trucks:	4 (2012)	<input type="checkbox"/>	Night Thru/Switch:	13/0	<input type="checkbox"/>
School Buses:	8 (2014)	<input type="checkbox"/>	Train Service:	Freight, Intercity, Commuter	<input type="checkbox"/>
Street Types:	Divided Highway	<input type="checkbox"/>	Passenger Count/Day:	54	<input type="checkbox"/>
Thru Lanes:	6	<input type="checkbox"/>	Train Count Date:	05/01/2012	<input type="checkbox"/>
Aux Lanes:	4	<input type="checkbox"/>	Main Tracks:	2	<input type="checkbox"/>
Hazmat Route?	NO	<input type="checkbox"/>	Other Tracks:		<input type="checkbox"/>
Emergency Services Route?	YES	<input type="checkbox"/>			<input type="checkbox"/>

Emergency Notification Signs:	YES	<input type="checkbox"/>	Train Signals?	NO	<input type="checkbox"/>
Crossbuck(4x4 post):	0	<input type="checkbox"/>	Train Signal Proximity:	NO	<input type="checkbox"/>
Crossbuck Sign:	8	<input type="checkbox"/>	Train Detection:	Constant Warning Time	<input type="checkbox"/>
Stop Sign:	0	<input type="checkbox"/>	Event Recorder?		<input type="checkbox"/>
Yield Sign:	0	<input type="checkbox"/>	Number of Bells:	3	<input type="checkbox"/>
Low Ground Clearance Signs:	0	<input type="checkbox"/>	Post Mounted Flashing Lights:	0	<input type="checkbox"/>
Exempt Signs:	NO	<input type="checkbox"/>	Backlights, Incandescent		<input type="checkbox"/>
Trespass Signs:	YES	<input type="checkbox"/>	Roadway Gate Count:	4	<input type="checkbox"/>
W10-1	5	<input type="checkbox"/>	Pedestrian Gate Count:	2	<input type="checkbox"/>
W10-2	0	<input type="checkbox"/>	Gates:	2 Quad, Median Gates	<input type="checkbox"/>
W10-3	0	<input type="checkbox"/>	W10-8	0	<input type="checkbox"/>
W10-4	0	<input type="checkbox"/>	W10-9	0	<input type="checkbox"/>
W10-11	0	<input type="checkbox"/>	W10-9P	2	<input type="checkbox"/>
W10-12	0	<input type="checkbox"/>	W10-11a	0	<input type="checkbox"/>
R3-1a	0	<input type="checkbox"/>	W10-11b	0	<input type="checkbox"/>
R3-2a	0	<input type="checkbox"/>	W10-13P	0	<input type="checkbox"/>
R8-8	0	<input type="checkbox"/>	W10-14P	0	<input type="checkbox"/>
R8-9	0	<input type="checkbox"/>	W10-14aP	0	<input type="checkbox"/>
R8-10	0	<input type="checkbox"/>	W10-15P	0	<input type="checkbox"/>
R8-10a	0	<input type="checkbox"/>	Slow	0	<input type="checkbox"/>
R10-6	0	<input type="checkbox"/>	W10-1w/Beacon	0	<input type="checkbox"/>
		<input type="checkbox"/>	LED Signs	0	<input type="checkbox"/>

Surface Installment Date:		<input type="checkbox"/>	Install - Upgrade:	-- 03/26/1987	<input type="checkbox"/>
Surface Type:	CONCRETE	<input type="checkbox"/>	Maintenance Responsibility:	COUNTY	<input type="checkbox"/>
Pvmt Mrk:	STOPLINES AND XING SYMBOLS	<input type="checkbox"/>	Roadway Paved:	YES	<input type="checkbox"/>
Surface Condition:	GOOD	<input type="checkbox"/>	Tracks run down street?	NO	<input type="checkbox"/>
Approach:	LOS B = Uneven	<input type="checkbox"/>	Sidewalks on Crossing Approach?	YES	<input type="checkbox"/>
Vehicle Reaction:	LOS B = Vibrating	<input type="checkbox"/>	Sidewalks Thru Crossing?	YES	<input type="checkbox"/>
Driver Reaction:	LOS A = No reaction	<input type="checkbox"/>	Crossing illuminated?	YES	<input type="checkbox"/>
Rail/Pad Movement:	LOS A = Smooth	<input type="checkbox"/>	Commerical Power?	YES	<input type="checkbox"/>
Incident History:	10/2009, 08/2008, 02/2001, 10/1995, 03/1994, 08/1991		Alternative Power?	NO	<input type="checkbox"/>

Recommended Warning Device: OVERPASS

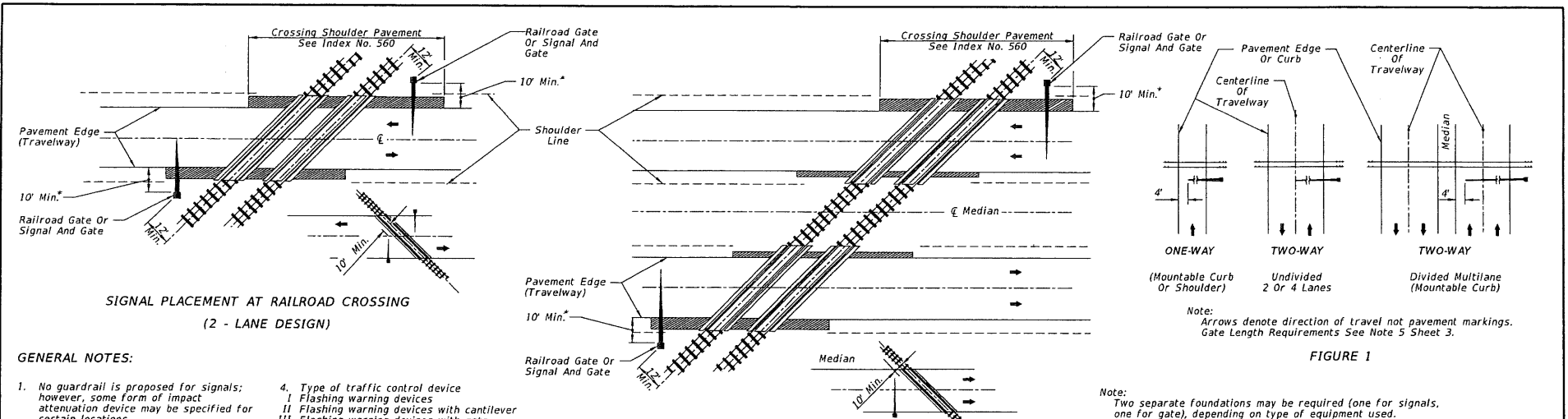

GENERAL NOTES:

- No guardrail is proposed for signals; however, some form of impact attenuation device may be specified for certain locations.
- Advance flasher to be installed when and if called for in plans or specifications.
- Top of foundation shall be no higher than 4" above finished shoulder grade.
- Type of traffic control device
 - Flashing warning devices
 - Flashing warning devices with cantilever
 - Flashing warning devices with gate
 - Flashing warning devices with cantilever and gate
 - Gate
- Class of traffic control devices (Not Shown)
 - 2 Quadrant flashing warning devices-one track
 - 2 Quadrant flashing warning devices-multiple tracks
 - 2 Quadrant flashing warning devices and gates-one track
 - 2 Quadrant flashing warning devices and gates-multiple tracks
 - 3-4 Quadrant flashing warning devices and gates-one track
 - 2-4 Quadrant flashing warning devices and gates-multiple tracks

Note: Two separate foundations may be required (one for signals, one for gate), depending on type of equipment used.

* When 10' is deemed impracticable the control device can be located as close as 2' from the edge of a paved shoulder but not less than 6' from the edge of the near traffic lane.

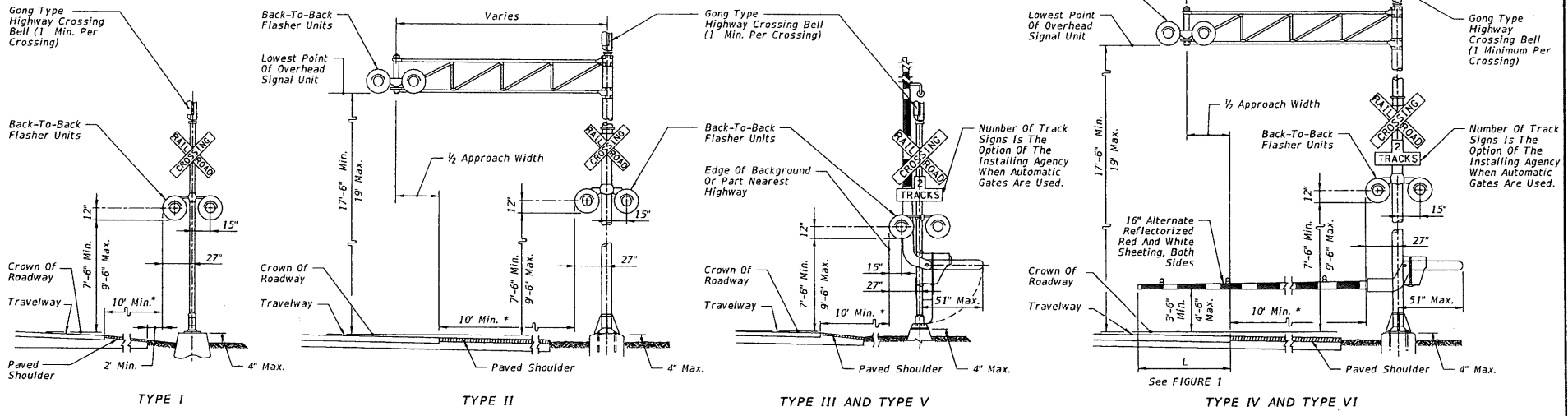

11/07/2016 9:25:08 AM

LAST REVISION 11/07/16	DESCRIPTION:	FDOT FY 2017-18 DESIGN STANDARDS	RAILROAD GRADE CROSSING TRAFFIC CONTROL DEVICES	INDEX NO. 17882	SHEET NO. 1 of 4
---------------------------	--------------	--	--	--------------------	---------------------

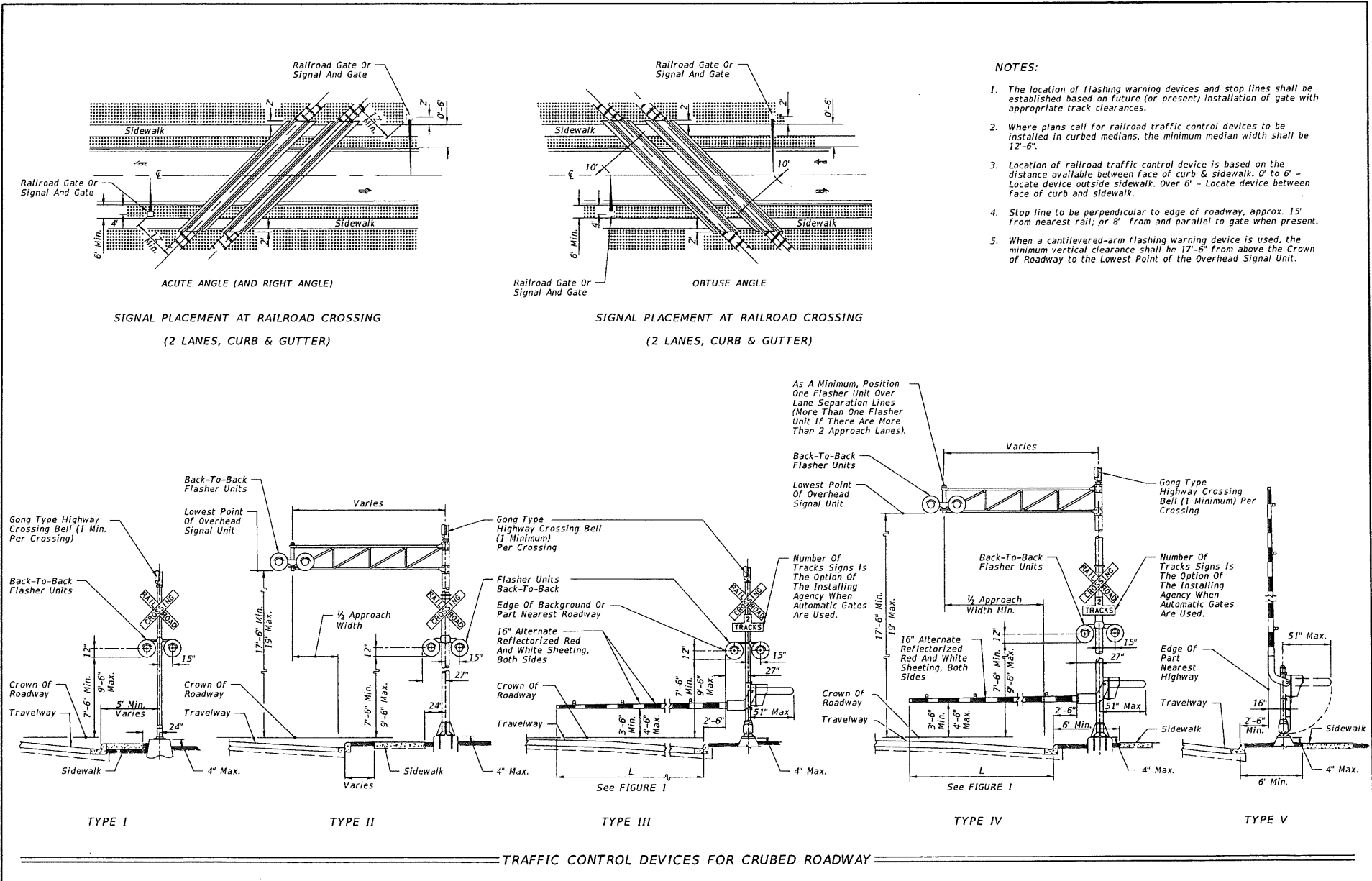

- NOTES:**
1. The location of flashing warning devices and stop lines shall be established based on future (or present) installation of gate with appropriate track clearances.
 2. Where plans call for railroad traffic control devices to be installed in curbed medians, the minimum median width shall be 12'-6".
 3. Location of railroad traffic control device is based on the distance available between face of curb & sidewalk. 0' to 6' - Locate device outside sidewalk. Over 6' - Locate device between face of curb and sidewalk.
 4. Stop line to be perpendicular to edge of roadway, approx. 15' from nearest rail; or 8' from and parallel to gate when present.
 5. When a cantilevered-arm flashing warning device is used, the minimum vertical clearance shall be 17'-6" from above the Crown of Roadway to the Lowest Point of the Overhead Signal Unit.

11/07/2016 9:22:11 AM

LAST REVISION 11/07/16	REVISION	DESCRIPTION:	FDOT	FY 2017-18 DESIGN STANDARDS	RAILROAD GRADE CROSSING TRAFFIC CONTROL DEVICES	INDEX NO. 17882	SHEET NO. 2 of 4
----------------------------------	-----------------	--------------	-------------	--------------------------------	--	--------------------	---------------------

RAILROAD CROSSING AT TWO (2)-LANE ROADWAY

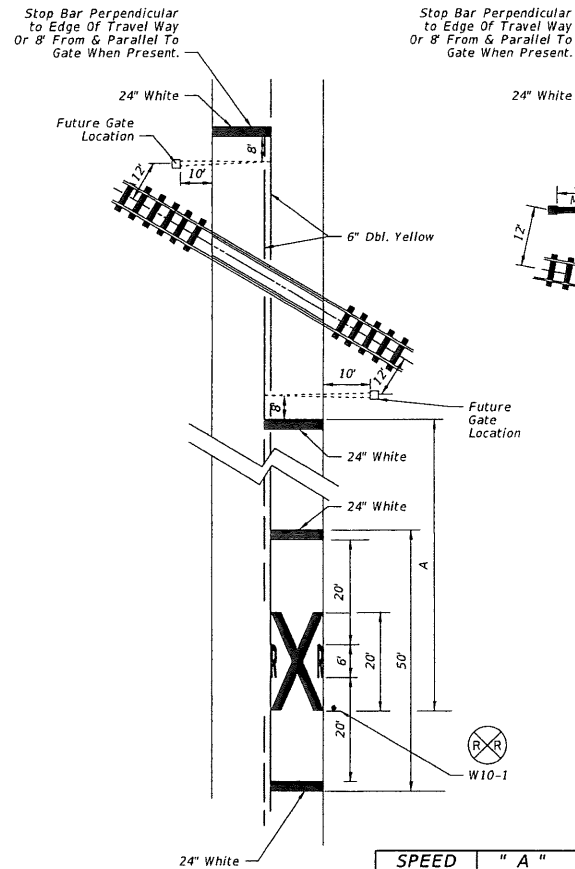

RAILROAD CROSSING AT MULTILANE ROADWAY

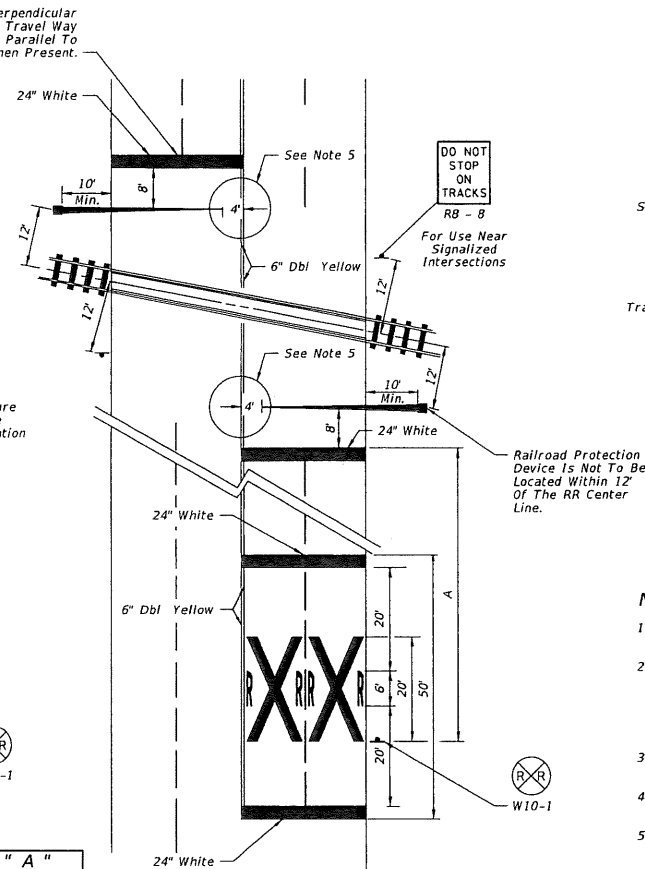

RELATIVE LOCATION OF CROSSING TRAFFIC CONTROL DEVICES

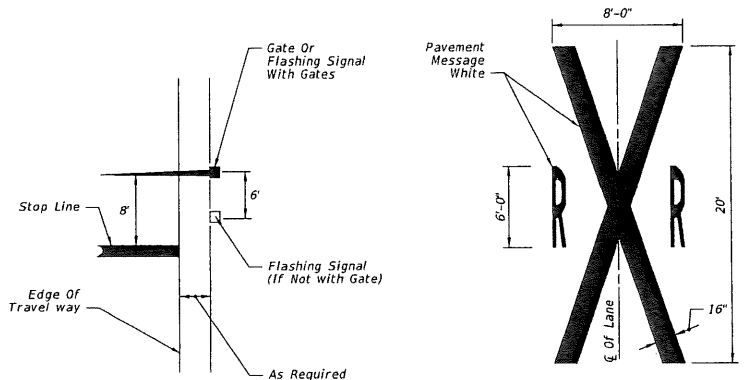

NOTES:

1. When computing pavement message, quantities do not include traverse lines.
2. Placement of sign W10-1 in a residential or business district, where low speeds are prevalent, the W10-1 sign may be placed a minimum distance of 100' from the crossing. Where street intersections occur between the RR pavement message and the tracks an additional W10-1 sign and additional pavement message should be used.
3. A portion of the pavement markings symbol should be directly opposite the W10-1 sign.
4. Recommended location for FTP-61-06 or FTP-62-06 signs, 100' urban and 300' rural. See Index 17355 for sign details.
5. Gate Length Requirements:
For Two-way undivided sections:
The gate should extend to within 1' of the center line. On multiple approaches the maximum gate length may not reach to within 1' of the center line. For those cases, the distance from the gate to the center line shall be a maximum of 4'.
For one-way or divided sections:
The gate shall be of sufficient length such that the distance from the gate tip to the inside edge of pavement is a maximum of 4'.

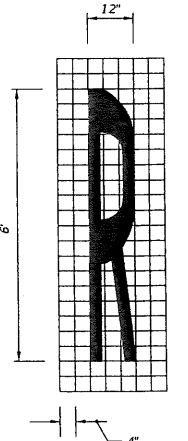

SPEED (mph)	" A " (ft)
60	400
55	325
50	250
45	175
40	125
35	100
URBAN	85 MIN.

10/14/2016 13:41:12 PM

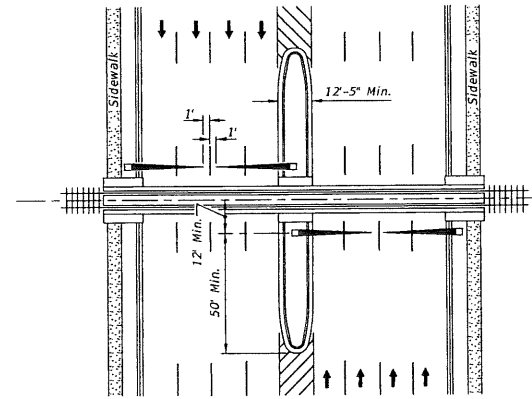
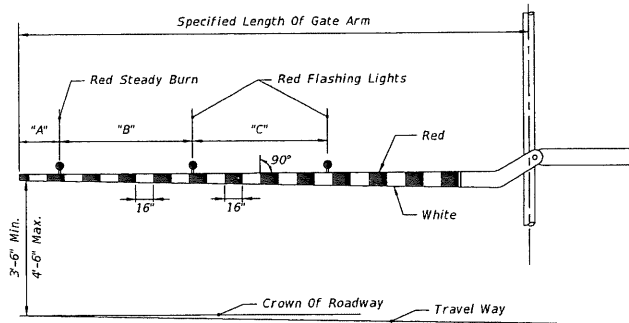

PLAN

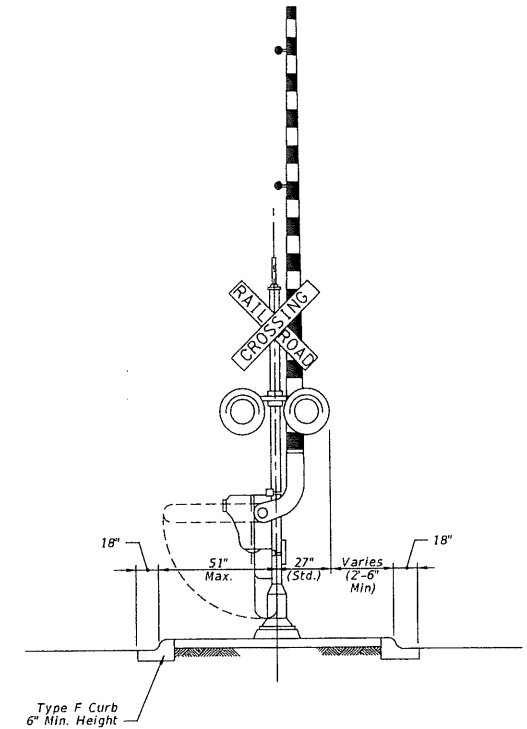

MEDIAN SECTION AT SIGNAL GATES

RAILROAD GATE ARM LIGHT SPACING

Specified Length Of Gate Arm	Dimension "A"	Dimension "B"	Dimension "C"
14 Ft.	6"	36"	5'
15 Ft.	18"	36"	5'
16-17 Ft.	24"	36"	5'
18-19 Ft.	28"	41"	5'
20-23 Ft.	28"	4'	5'
24-28 Ft.	28"	5'	5'
29-31 Ft.	36"	6'	6'
32-34 Ft.	36"	7'	7'
35-37 Ft.	36"	9'	9'
38 And Over	36"	10'	10'

NOTE:
For additional information see the "Manual On Uniform Traffic Control Devices", Part 8; The "Traffic Control Handbook", Part VIII; and AASHTO "A Policy On Geometric Design Of Streets And Highways".

MEDIAN SIGNAL GATES FOR
MULTILANE UNDIVIDED URBAN SECTIONS

(THREE OR MORE DRIVING LANES IN ONE DIRECTION, 45 MPH OR LESS)

10/14/2016 12:41:15 PM

LAST REVISION 01/01/12	DESCRIPTION:	FDOT FY 2017-18 DESIGN STANDARDS	RAILROAD GRADE CROSSING TRAFFIC CONTROL DEVICES	INDEX NO. 17882	SHEET NO. 4 of 4
---------------------------	--------------	--	--	--------------------	---------------------