

**PALM BEACH COUNTY  
BOARD OF COUNTY COMMISSIONERS  
AGENDA ITEM SUMMARY**

Meeting Date: October 6, 2020

Consent  
 Workshop

Regular  
 Public Hearing

Department: Facilities Development & Operations

**I. EXECUTIVE BRIEF**

**Motion and Title: Staff recommends motion to approve:** Change Order No. 2 to Amendment No. 22 to the continuing construction management (CM) contract (2016-0762) with Robling Architecture Construction, Inc. increasing the project value for the Palm Beach County Sheriff's Office (PBSO) Temporary Space at the South Florida Water Management District (SFWMD) Building in the amount of \$128,090.48 and increasing the project duration by 22 calendar days.

**Summary:** On May 5, 2020, the Board of County Commissioners approved Amendment No. 22 with Robling Architecture Construction, Inc. in the amount of \$219,837 to reconfigure the existing floor plan at the SFWMD facility to incorporate a tenant separation partition throughout the existing third floor space with a new entry storefront for PBSO access, as well as, access doors, access controls, heating ventilation and air conditioning (HVAC) upgrades, new electrical, fire alarm, fire sprinklers, data drops and exit lights. The project was delayed due to a combination of revisions to the drawings that were owner initiated and required as per the building code. Change Order No. 2 consists of the additional time and funds needed to accommodate additional general project requirements, labor and the procurement of the equipment as a result of the requested changes. The work consists of installation of five (5) modular furniture doors with electric strikes, delayed egress hardware, as well as, installation of eighteen ceiling mounted occupancy sensors. On June 21, 2016, the Board of County Commissioners (BCC) approved the continuing CM contract with Robling Architecture Construction Inc., for construction management services for capital projects under \$2,000,000. The continuing CM contract was awarded pursuant to the Small Business Enterprise (SBE) ordinance but this amendment, having been initiated after January 1, 2019, is subject to the requirements of the Equal Business Opportunity (EBO) ordinance. The Construction Manager is an SBE. The continuing CM contract was presented to the Goal Setting Committee on February 20, 2019 and an Affirmative Procurement Initiative (API) of 20% SBE participation was applied to the contract. SBE participation on this change order is 100%. To date the Construction Manager has achieved 57.68% SBE subcontracting participation under its continuing contract. The CM is a Palm Beach County business. The funding source for this project is from the Public Building Improvement Fund. **(Capital Improvements Division) Countywide/District 2 (LDC)**

**Background & Justification:** CM at Risk is a project delivery method in which the CM provides design phase assistance, evaluation of cost, schedule and implications of alternate designs, systems and materials, and serves as the general contractor bidding the subcontracts for construction. Change Order No. 2 increases the contract duration by 22 calendar days for a total of 82 calendars and the project value by \$128,090.48 for a not to exceed project value of \$376,847.23.

**Attachments:**

1. Location Map
2. Budget Availability Statement
3. Change Order No. 2

Recommended by: *Dawn J. Ayala Collins* *9/21/20*  
 Deputy Director Department Director Date

Approved by: *[Signature]* *10/1/20*  
 County Administrator Date

**A. Five Year Summary of Fiscal Impact:**

Fiscal Years	2021	2022	2023	2024	2025
Capital Expenditures	\$153,091	_____	_____	_____	_____
Operating Costs	_____	_____	_____	_____	_____
External Revenues	_____	_____	_____	_____	_____
Program Income (County)	_____	_____	_____	_____	_____
In-Kind Match (County)	_____	_____	_____	_____	_____
<b>NET FISCAL IMPACT</b>	\$153,091	<u>-0-</u>	<u>-0-</u>	<u>-0-</u>	<u>-0-</u>
# ADDITIONAL FTE POSITIONS (Cumulative)	_____	_____	_____	_____	_____
Is Item Included in Current Budget:		Yes	<u>X</u>	No	_____
Does this item include use of federal funds?		Yes	_____	No	<u>X</u>

Budget Account No: Fund 3804 Dept 411 Unit B545-02 Object 4907

**B. Recommended Sources of Funds/Summary of Fiscal Impact:**

The funding source for this project is from the Public Building Improvement Fund  
 Change Order No. 2 \$128,090.48  
 Project Contingency \$25,000.00  
 Total \$153,090.48

C. Departmental Fiscal Review: 

**III. REVIEW COMMENTS**

**A. OFMB Fiscal and/or Contract Development Comments:**

 9/23/2020  
 OFMB  
 9/22

 9/29/2020  
 Contract Development and Control  
 9-28-20 TW

**B. Legal Sufficiency:**

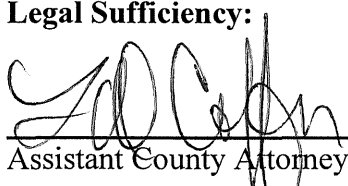
 9/30/2020  
 Assistant County Attorney

**C. Other Department Review:**

\_\_\_\_\_  
 Department Director

**This summary is not to be used as a basis for payment.**

# LOCATION MAP

Project No: 20149

Project Name Palm Beach County Sheriff's Office (Pbso) Temporary Space At South Florida Water Management District (Sfwmd) Building

Location: 3301 Gun Club Road, West Palm Beach



BUDGET AVAILABILITY STATEMENT

REQUEST DATE: 09/03/2020

REQUESTED BY: Jim Daley

PHONE: 233-4408

PROJECT TITLE: PBSO Temporary Space at SFWMD Building  
(Same as CIP or IST, if applicable)

IST PLANNING NO.:

ORIGINAL CONTRACT AMOUNT: NA – Annual

BCC RESOLUTION#: R2020-0519

REQUESTED AMOUNT: \$153,090.48  
EFDO #2020-017699

DATE: 5/5/2020

CSA or CHANGE ORDER NUMBER: CO #2

LOCATION: 3301 Gun Club Road, WPB

BUILDING NUMBER:

DESCRIPTION OF WORK/SERVICE LOCATION:

PROJECT/W.O. NUMBER: 20149

CONSULTANT/CONTRACTOR: Robling Architecture Construction, Inc.

PROVIDE A BRIEF STATEMENT OF THE SCOPE OF SERVICES TO BE PROVIDED BY THE CONSULTANT/CONTRACTOR:

- 1. CCP #03 Labor and materials for revisions to HVAC, electrical, fire protection, fire alarm and card access to accommodate owner requested changes made to the project.....\$93,834.07
  - 2. CCP #04: Furnish and install five Schlage cylindrical locks at modular furniture doors, five electric strikes, and delayed egress hardware at three modular furniture doors .....\$18,648.16
  - 3. CCP #05: Labor and materials for installation of eighteen ceiling mounted lighting occupant sensors ....\$15,608.25
- Total .....\$128,090.48

CONSTRUCTION	\$128,090.48
PROFESSIONAL SERVICES	\$
STAFF COSTS*	\$
EQUIP. / SUPPLIES/PERMITS	\$
CONTINGENCY	\$ 25,000.00
TOTAL	\$153,090.48

\* By signing this BAS your department agrees to these CID staff charges and your account will be charged upon receipt of this BAS by FD&O. Unless there is a change in the scope of work, no additional staff charges will be billed. If this BAS is for construction costs of \$250,000 or greater, staff charges will be billed as actual and reconciled at the end of the project. If the project requires Facilities Management or ESS staff your department will be billed actual hours worked upon project completion.

**BUDGET ACCOUNT NUMBER(S) (Specify distribution if more than one and order in which funds are to be used):**

FUND: 3804

DEPT: 411

UNIT: B545-02

OBJ: 4907

**IDENTIFY FUNDING SOURCE FOR EACH ACCOUNT: (check and provide detail for all that apply)**

- Ad Valorem (Amount \$ \_\_\_\_\_)       Infrastructure Sales Tax (Amount \$ \_\_\_\_\_)
- State (source/type: \_\_\_\_\_ Amount \$ \_\_\_\_\_)       Federal (source/type: \_\_\_\_\_ Amount \$ \_\_\_\_\_)
- Grant (source/type: \_\_\_\_\_ Amount \$ \_\_\_\_\_)       Impact Fees: (Amount \$ \_\_\_\_\_)
- Other (source/type: \_\_\_\_\_ Amount \$ \_\_\_\_\_)

Department: FD&O

BAS APPROVED BY: [Signature]

DATE 9/15/2020

ENCUMBRANCE NUMBER: \_\_\_\_\_

**CHANGE ORDER BRIEF**  
**PALM BEACH COUNTY SHERIFF'S OFFICE (PBSO) TEMPORARY SPACE AT SOUTH**  
**FLORIDA WATER MANAGEMENT DISTRICT (SFWMD) BUILDING**  
**PROJECT NO. 20149**  
**AUGUST 24, 2020**  
**CONTRACT NO. R2016-0762 (R2020-0519)**

---

Prime Contractor ..... Robling Architecture Construction, Inc.

Change Order No. .... 02

Change Order Amount ..... \$128,090.48

Changed Contract Time ..... 22 calendar days

Description of Construction Change Proposals (CCPs):

1. CCP #03 Labor and materials for revisions to HVAC, electrical, fire protection, fire alarm and card access to accommodate owner requested changes made to the project ..... \$93,834.07
  2. CCP #04: Furnish and install five Schlage cylindrical locks at modular furniture doors, five electric strikes, and delayed egress hardware at three modular furniture doors..... \$18,648.16
  3. CCP #05: Labor and materials for installation of eighteen ceiling mounted lighting occupant sensors..... \$15,608.25
- Total CCP's..... \$128,090.48

Reason for Change and Code:

1. CCP #03: (O) Revisions to the project were required due to owner changes dated 5/29/20 summarized as follows:  
 PBSO Internal Affairs requested additional privacy and security. The modular furniture walls had to extend to the ceiling, 1 work space became 4 spaces and additional doors were equipped with card readers. Sprinkler heads had to be added and relocated, fire alarm devices were added, the existing circuiting and data/voice outlets were modified.
2. CCP #04: (O) Related to the changes to the space outlined in CCP#03, CCP#04 is for the locks, electric strikes and delayed egress hardware for the same doors.
3. CCP #05: (Z) This is a code requirement. The original design did not include these and they were captured on the revised drawings from 5/29/20.

Reason-for-change codes

D = Differing Site Conditions	R = Request by another Agency/Outside Party
E = Errors/Omissions in Design	X = Other (Specify: )
O = Owner-Initiated	Z = Zoning/Code/Ordinance Change
Q = Quantity Adjustments	

Estimated premium value of errors/omissions for this change order: \$0.00

SUBMITTED:

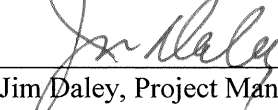
  
 \_\_\_\_\_  
 Jim Daley, Project Manager  
 Capital Improvements Division

9.18.20  
 \_\_\_\_\_  
 Date

If applicable:

Original SBE participation for this Project: 44.98%  
 SBE participation for this Change Order: 63.84%  
 Revised SBE participation for Project after adjusted for Change Order: 53.24%



**PALM BEACH COUNTY**

**CHANGE ORDER**

ISSUED TO: Robling Architecture Construction, Inc.  
101 Walker Avenue  
Greenacres, FL 33463

CHANGE ORDER NO.: 02  
AMENDMENT NO: 22 (R2020-0519)

PROJECT NAME: PBSO Temporary Space at SFWMD  
PROJECT NO. 20149

REFERENCE CCP NO.: 03, 04 & 05  
RESOLUTION NO.: R2016-0762  
DISTRICT NO.: 2

The completion date, contract price, and all terms, covenants, and conditions of the above referenced contract, except as duly modified by this and previous Change Orders, if any, shall remain in full force and effect.

**DESCRIPTION OF CHANGE:**

- 1. CCP #03 Labor and materials for revisions to HVAC, electrical, fire protection, fire alarm and card access to accommodate owner requested changes made to the project.....\$93,834.07
- 2. CCP #04: Furnish and install five Schlage cylindrical locks at modular furniture doors, five electric strikes, and delayed egress hardware at three modular furniture doors.....\$18,648.16
- 3. CCP #05: Labor and materials for installation of eighteen ceiling mounted lighting occupant sensors ....\$15,608.25
- Total.....\$128,090.48

**CONTRACT PRICE**

**COMPLETION DATE**

Original Contract Price (TO #27):	\$3,919.75
Amendment No. 22:	\$219,837.00
Previous CO #0 through 01:	\$0.00
This Change Order No. #02 :	\$128,090.48
ADJUSTED Contract Price:	\$351,847.23

Contract Completion Date will be increased by 22 calendar days.  
Contract Notice to Proceed Date: 06/15/2020  
Contract Substantial Completion Date: 08/14/2020  
ADJUSTED Substantial Completion Date: 09/05/2020

**CONTRACTOR**

Execution of this change order acknowledges final settlement of, and releases, all claims for costs and time associated, directly or indirectly, with the above stated modification(s), including all claims for cumulative delays or disruptions resulting from, caused by, or incident to such modifications(s), and including any claim that the above stated modification(s) constitutes, in whole or part, a cardinal change to the contract. The above changes are accepted:

Robling Architecture Construction, Inc.  
Contractor  
By:   
Print Name: Damon A Robling  
Title: President Date: 9/14/2020

**DESIGN PROFESSIONAL**

The above changes are recommended for approval by the Owner:

Colome & Associates, Inc.  
Design Professional  
By:   
Print Name: Joe Colome  
Title: Project Manager Date: 9/14/2020

**PALM BEACH COUNTY**

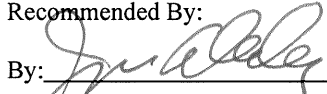
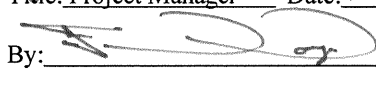
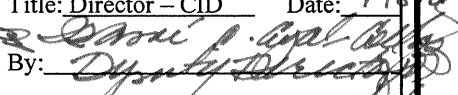
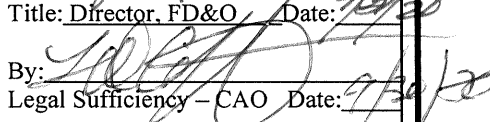
Recommended By:  
By:   
Title: Project Manager Date: 9-18-20  
By:   
Title: Director - CID Date: 9-18-20  
By:   
Title: Director, FD&O Date: 9/24/20  
By:   
Legal Sufficiency - CAO Date: 9/30/20  
Approved By:  
By: \_\_\_\_\_  
Title: Mayor, BCC Date: \_\_\_\_\_

PALM BEACH COUNTY

CONSTRUCTION CHANGE PROPOSAL (CCP)

TO: Palm Beach County  
2633 Vista Parkway  
West Palm Beach, FL 33411

CCP NUMBER: 03

DATE: 8/11/2020

ATTENTION: Jim Daley

PROJECT NAME: SFWMD B2 Bldg 3rd Floor Improv.

PROJECT NUMBER: 20149

REFERENCE:

CONTRACT NUMBER:

We propose to accomplish the MODIFICATIONS identified in FIELD BULLETIN FB # N/A and as described herein. Except as modified below, the original contract and all prior amendments shall remain in full force and effect.

DESCRIPTION:

HVAC, Electrical & Systems revisions per revised drawings FP-2, M-1, M-3, E-2, E-3, E-4, E-5, E-6 & E-7 Rev. 2, Owner Changes dated 5/29/2020; summarized as follows  
Fire Protection: Modify sprinklers to accommodate additional partitions  
HVAC: Modify air distribution to accommodate new full-height partitions  
Electrical Lighting: Add (9) exit signs and (8) 2x2 fixtures  
Electrical Power: Add dedicated circuits for printers (11) locations  
Fire Alarm: Add (15) notification devices and over-ride for delayed egress  
Card Access: Add (8) card reader locations including delayed egress devices

PROPOSED CONTRACT PRICE CHANGE ( INCREASE ) \$ 93,834.07

PROPOSED CONTRACT TIME CHANGE ( N/A ) 22 days

PROPOSED NEW SUBSTANTIAL COMPLETION 9/05/2020 date

FROM: Robling Architecture Construction, Inc.  
CONTRACTOR

DISTRIBUTION:

SIGNED: *B & all*

DATE: 8/11/2020



**PALM BEACH COUNTY**

**CCP CALCULATION SHEET**

TO: Palm Beach County  
 2633 Vista Parkway  
 West Palm Beach, FL 33411

CCP NUMBER: 03  
 DATE: 8/11/2020  
 PROJECT NAME: SFWMD B2 Bldg 3rd Floor Improv.  
 PROJECT NUMBER: 20149  
 CONTRACT NUMBER:

ATTENTION: Jim Daley

REFERENCE:

Item	Description	Labor Unit Cost	Labor Qty	Labor Total	Material Unit Cost	Material Qty	Material Total	Total Cost / Subcontractor Cost
1	Credit for demolition of interior door at room 312/313							(\$ 1,800.00)
2	Airtex Corp. (HVAC), Owner Changes Rev2							\$ 14,510.07
3	Protect Video (Card Access)							\$ 11,500.00
4	Brigade Fire							\$ 650.00
5	Knight Fire (Fire Alarm)							\$ 15,810.00
6	Malone Electrical (Power, Lighting)							\$ 53,164.00
7								
<b>Total</b>								<b>\$93,834.07</b>

CCP- 03

CCP- 03



# The Airtex Corporation

**HVAC Systems – Specialty Metals**

Commercial / Industrial

CSC1110262 CAC1815780

**June 5, 2020**

MECHANICAL REV. 2 CHANGES  
DATED 5/29/2020 OWNER CHANGES

**Robling Architecture Construction  
101 Walker Avenue  
West Palm Beach, FL**

**Project : SFWMD PBSO  
Reference: Rev # 2  
Airtex Proposal: # 2**

**Attn: Brian Allen**

**We herewith submit our itemized proposal for the performance of the referenced work. Our direct costs and reasonable mark-ups for this work is \$ ~~20,476.00~~ as detailed on the enclosed breakdown sheets.**

\$14,510.07

**The above costs do not include any impact for the base contract work; we reserve the right to examine the impact of this change on the overall schedule at a later date and request appropriate time and cost compensation should the accumulative effect of this or other changes warrant. Costs are based on the RS Means Mechanical cost data 2017.**

**Scope of work: Changes in accordance with Rev # 2 dated 5/29/2020**

---

---

---

---

---

**Exclusions: As listed on original bid**

**Please be advised that this price coverage is good for a period of (15) days.**

**Should you wish us to proceed, kindly forward a written notice or change order for the above listed amount.**

**Respectfully,  
The Airtex Corporation**

**Ken Kammer  
Project Manager**

PH. 561-683-3446 Fax 561-683-3414  
1450- B Skees Road - West Palm Beach, Florida 33411  
Airtexcorp.com



# The Airtex Corporation

## COST SUMMARY

Project SFWMD PBSO  
 Reference: Rev # 2  
 Airtex Proposal #: 2

G.C. Proposal #: 0  
 Project Manager: Ken  
 Date: 6/5/2020

DESCRIPTION				COST	TOTAL
<b>MATERIALS</b>				\$ 4,965.00	
EQUIPMENT RENTAL				\$0.00	
BLUEPRINTS				\$63.70	
TAX @ 7.0%				\$352.00	
<b>SUB-TOTAL</b>				\$ 5,380.70	\$5,381
<b>SUBCONTRACTOR</b>					
TEMPERATURE CONTROL					
INSULATION					
TEST & BALANCE				<del>\$4,650</del>	\$1,700.00
PLUMBING					
ELECTRICAL					
<b>SUB-TOTAL</b>				\$4,650	\$4,650
					\$1,700.00
<b>LABOR</b>					
FOREMAN	32.43	HOURS	\$61.10	\$1,982.00	
JOURNEYMAN	32.43	HOURS	\$49.23	\$1,597.00	
APPRENTICE	32.43	HOURS	\$37.15	\$1,205.00	
LABORER	9.73	HOURS	\$19.33	\$188.00	
SERVICE TECHNICIAN		HOURS	\$98.35	\$0.00	
DRAFTING	4.86	HOURS	\$131.00	\$637.00	
SUB-C/FIELD SUPERVISION	2.00	HOURS	\$73.60	\$147.00	
TRUCKING	1	HOURS	\$66.21	\$66.00	
PROJECT ENGINEER		HOURS	\$84.22	\$0.00	
RIGGING		HOURS	\$193.00	\$0.00	
<b>SUB-TOTAL</b>				\$5,822.00	\$5,822
<b>JOB COSTS</b>					\$0.00
PERMIT FEE SCHEDULE	1%			<del>\$159</del>	\$258.06
GENERAL CONDITIONS	2%			<del>\$317</del>	
<b>SUB-TOTAL</b>				\$476	\$476
					\$258.06
<b>TOTAL COST</b>					\$16,329
OVERHEAD	<del>14%</del> 5%				<del>\$2,286</del> \$658.05
<b>SUBTOTAL</b>					\$18,615
PROFIT	<del>10%</del> 5%				\$1,861
<b>SUBTOTAL</b>					\$20,476
<b>BOND</b>					\$0
<b>TOTAL</b>					\$20,476
					\$14,510.07





ELECTRICAL REV. 2 CHANGES  
DATED 5/29/2020 OWNER CHANGES

3483 High Ridge Rd  
Boynton Beach, FL 33426

FL License# EC13006713  
Telephone 561-622-5880

Att: Brian Allen  
Robling Construction

June 4, 2020

**Re: SFWMD PBSO Access Control – Proposal**

- 1 – LNL-2220 2 Door Controller
- 8 – LNL-1320-S3 dual reader Boards
- 1 – Life Safety Power Supply Enclosure with Power Supply & Relay Boards
- 18 – HID RP40 Reader
- 15 – Honeywell IS310WH Request-to-Exit Motion
- 15 – Door Position Switch

GMP ALLOWANCE FOR CARD ACCESS: \$25,000 (11 READERS)

Total = \$36,500.00

NET ADDED COST FOR THIS CCP: \$36,500 - \$25,000 = **\$11,500**

Note: Does not include software or programming.

Sincerely,  
Shad DiMaria,  
**Protect Video, Inc**

State Electrical Contractor  
Vendor Certification for County, State and US Government.  
Woman Owned WMBE Business

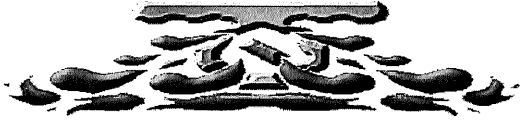

*For An Ounce Of Prevention*

## **Brigade Fire Protection Inc.**

16562 89th PL N. West Palm Beach FL 33470  
(561) 333-9243

Date 6/25/20

To: Robling Architecture Construction, Inc.  
1801 Lee Road, Suite 301  
Winter Park, FL 32789

Contract #: 16748

RE: Tenant Improvement Bldg B2  
3301 Gun Club Rd.  
Palm Beach County

Work to be performed for the  
amount of: \$650.00

### **We Propose**

To add or detract the original contract, #16707, with this Change Order for additional work or credit.

To revise and submit drawings showing additional heads.

To install two additional heads.

Our terms for payment are that we receive payment upon the draw following the change order work.

#### **Proposal Acceptance**

Customer Representative (Please Print): \_\_\_\_\_

Signature: \_\_\_\_\_ Date: \_\_\_\_\_



# knight Fire & Security

7513 Central Industrial Drive  
Riviera Beach, FL 33404

Phone: 561-471-8221

Fax: 561-471-1488

## Change Order #1

July 7, 2020- Revised after survey with GC on 7-7-2020

**Project:**

**PBC SFWMD PBOS Tenant Space**  
3301 Gun Club Road Building #2  
West Palm Beach, Florida

**Attention: Brian Allen**

**ELECTRICAL REV. 2 CHANGES  
DATED 5/29/2020 OWNER CHANGES**

**Contact:**

**Robling Architecture Construction, Inc.**  
101 Walker Avenue  
Greenacres, Florida 33463  
Office: 561-649-6705 Cell:561-718-6893

**JOB: PBOS Tenant Space Bldg.# 2, 3<sup>rd</sup> Floor**  
**KFS JOB # C-30066**  
**Project: Fire Alarm System**

**Work Description:** The following is a change order adds for labor and material needed for the following:

- (01) NAC Power Supply**
- (01) Smoke Detector**
- (06) Horn Strobes**
- (09) Fire Warning Strobes**
- (01) Installation/labor**
- (01) Programming & Testing**
- (01) Complete Field Evaluation**
- (01) Revised Plans**
- (01) Relay Module (3 doors for new Access System for (01) Power Supply supplied & Installed by others)**

**Materials & Labor: \$15,810.00**

**NOTE:** An evaluation to all of the new installed devices and wiring out in the field will be tested for full functionality after the above required devices are installed by Knight Fire & Security.

If any replacements of devices/ wiring or repairs are required this will be quoted at the time of service and will be additional that is not included in the above Change Order #1 indicated above.

Thank You,

*Joseph Cipoletto*

Project Sales  
Knight Fire & Security  
561-232-5723

\_\_\_\_\_  
(Approval please sign (Brian Allen))

## Change Order

Malone Electrical Solutions, LLC.  
1540 Donna Road  
West Palm Beach, Florida 33409  
Phone (561) 242-0680  
Fax (561) 242-0882

Proposal Submitted To: Robling Architecture Construction Inc.  
Attn: Brian Allen  
Street Address: 101 Walker Ave  
City, State, Zip Code: Green Acres, FL 33463  
Phone Number: 561-649-6705  
Date of Proposal: July 2, 2020  
Job Name: SFWMD Building B2, 3<sup>rd</sup> Floor PBSO

**Proposed bid price to provide additional electrical as per Revision 2 sheets: # E-2, E-3, E-4, E-5, E-6, & E-7 Dated: 5/29/20, from Colome & Associates Inc..  
Qualification to include the following:**

### **Sheet E-2:**

- Furnish and install (09) additional ceiling mounted "Exit" lights TYPE X
- Furnish and install (09) additional 2 X 2 lay in fixtures as shown TYPE B
- Furnish and install (07) wall occupancy sensors as shown
- Credit (03) Fixture relocations

### **Sheet E-3:**

- Install boxes, red conduit, and pull string to interconnect (05) horn/strobes
- Install boxes, red conduit, and pull string to interconnect (04) strobes
- Install (11) printer/copier receptacles and (14) dedicated circuits back to electrical panel. (08) L/V stubs not put in and ran through cubicles
- Install (10) 4 1 1/16" box with 1" EMT conduit stub up into ceiling with pull-strings for (10) data printer locations
- Installation for Card Reader at (05) additional locations. Includes conduit to above door only and corresponding conduit from control panel to above ceiling. Banana cable to be installed by others
- Installation for Delayed Entry Card Reader at (03) additional locations. Includes conduit to above door only and corresponding conduit from control panel to above ceiling. Banana cable to be installed by others
- Disconnect and pull back power and data at (10) additional cubicle locations. Roll data wiring into ceiling as directed. Re-divert power to new location as requested by cubicle sub-contractor

### **Sheet E-6:**

- Add (15) 1P20 Amp breakers for circuitry in Panel "L3NC"



Continued,

**SUBTOTALS**

Lighting and controls	\$ 11,986.00
Occupancy Sensors	\$ 0.00
Fire Alarm Infrastructure	\$ 11,723.00
Printers high voltage conduit and wiring	\$ 17,442.00
Printers low voltage conduit ceiling stubs	\$ 3,026.00
Card Access	\$ 7,105.00
Panel breaker adders	\$ 1,882.00
<b>TOTAL PRICE:</b>	<b>\$ 53,164.00</b>

**OPTIONS (NOT INCLUDED IN BASE BID)**

**PERMIT ADDER (IF REQUIRED) \$ ~~797.00~~**

**FIFTY THREE THOUSAND – ONE HUNDRED SIXTY FOUR DOLLARS & XX/100  
\$53,164.00 (Permit fee not included)**

Ray Murdock  
Malone Electrical Solutions, LLC

**ACCEPTANCE of PROPOSAL** The above prices, Specifications, and Conditions are satisfactory and are hereby accepted. You are authorized to do the work as specified. Payment will be made on a monthly basis as billed.  
Date of Acceptance: \_\_\_\_\_

Signature \_\_\_\_\_

Print Name \_\_\_\_\_

Note: This proposal may be withdrawn by us  
If not accepted within 30 days

Term: Net 30 DAYS payment is due upon presentation of invoice. Past due accounts will be charged a 1.5% monthly finance charge. If action or suit is brought by Malone Electric, Inc. to collect any amount over due or owing under this bill, Customer agrees to pay all costs of collection including reasonable attorney's fees.

# OEBO SCHEDULE 1

## LIST OF PROPOSED CONTRACTOR/CONSULTANT AND SUBCONTRACTOR/SUBCONSULTANT PARTICIPATION

SOLICITATION/PROJECT/BID NAME: SFWMD B2 Bldg. 3rd Floor Renovation for PBSO  
 NAME OF PRIME RESPONDENT/BIDDER: Robling Architecture Construction, Inc.  
 CONTACT PERSON: Brian Allen  
 SOLICITATION OPENING/SUBMITTAL DATE: \_\_\_\_\_

SOLICITATION/PROJECT/BID No.: 20149  
 ADDRESS: 101 Walker Avenue, Greenacres, FL 33463  
 PHONE NO.: 561-649-6705 E-MAIL: ballen@robling.com  
 DEPARTMENT: Capital Improvements Division

**PLEASE LIST THE DOLLAR AMOUNT OR PERCENTAGE OF WORK TO BE COMPLETED BY THE PRIME CONTRACTOR/CONSULTANT ON THIS PROJECT. PLEASE ALSO LIST THE DOLLAR AMOUNT OR PERCENTAGE OF WORK TO BE COMPLETED BY ALL SUBCONTRACTORS/SUBCONSULTANTS ON THE PROJECT.**

Name, Address and Phone Number	(Check all Applicable Categories)			DOLLAR AMOUNT OR PERCENTAGE OF WORK				
	Non-SBE	M/WBE Minority/Women Business	SBE Small Business	Black	Hispanic	Women	Caucasian	Other (Please Specify)
1. Malone Electrical 1540 Donna Road, W Palm Beach 33409 561-242-0680 VC0000131964	<input type="checkbox"/>	<input type="checkbox"/>	<input checked="" type="checkbox"/>	_____	_____	_____	\$53,164.00	_____
2. The Airtex Corporation 1450 B Skees Road, West Palm Beach 33411 561-683-3446 VC0000106536	<input type="checkbox"/>	<input type="checkbox"/>	<input checked="" type="checkbox"/>	_____	_____	_____	\$14,510.07	_____
3. Protect Video, Inc. 3483 High Ridge Road, Boynton Beach 33426 561-622-5880 VC0000004897	<input type="checkbox"/>	<input checked="" type="checkbox"/>	<input checked="" type="checkbox"/>	_____	_____	\$11,500.00	_____	_____
4. Brigade Fire Protection 16562 89th Pl N, Loxahatchee 33470 (561) 333-9243 VS0000014544	<input checked="" type="checkbox"/>	<input type="checkbox"/>	<input type="checkbox"/>	_____	_____	_____	_____	\$650.00
5. Knight Fire & Security 2610 Old Okeechobee Road, West Palm Beach 561-471-8221 VC0000126707	<input checked="" type="checkbox"/>	<input type="checkbox"/>	<input type="checkbox"/>	_____	_____	_____	_____	\$15,810.00
(Please use additional sheets if necessary)				<b>SEE TOTALS ON PAGE 2</b>				
				Total	_____	_____	_____	_____
Total Bid Price \$ _____				Total SBE - M/WBE Participation _____				

I hereby certify that the above information is accurate to the best of my knowledge: \_\_\_\_\_  
Signature Title

- Note:**
1. The amount listed on this form for a Subcontractor/subconsultant must be supported by price or percentage listed on the properly executed Schedule 2 or attached signed proposal.
  2. Firms may be certified by Palm Beach County as an SBE and/or an M/WBE. If firms are certified as both an SBE and/or M/WBE, please indicate the dollar amount under the appropriate category.
  3. Modification of this form is not permitted and will be rejected upon submittal.

# OEBO SCHEDULE 1

## LIST OF PROPOSED CONTRACTOR/CONSULTANT AND SUBCONTRACTOR/SUBCONSULTANT PARTICIPATION

SOLICITATION/PROJECT/BID NAME: SFWMD B2 Bldg. 3rd Floor Renovation for PBSO  
 NAME OF PRIME RESPONDENT/BIDDER: Robling Architecture Construction, Inc.  
 CONTACT PERSON: Brian Allen  
 SOLICITATION OPENING/SUBMITTAL DATE: \_\_\_\_\_

SOLICITATION/PROJECT/BID No.: 20149  
 ADDRESS: 101 Walker Avenue, Greenacres, FL 33463  
 PHONE NO.: 561-649-6705 E-MAIL: ballen@robling.com  
 DEPARTMENT: Capital Improvements Division

**PLEASE LIST THE DOLLAR AMOUNT OR PERCENTAGE OF WORK TO BE COMPLETED BY THE PRIME CONTRACTOR/CONSULTANT ON THIS PROJECT. PLEASE ALSO LIST THE DOLLAR AMOUNT OR PERCENTAGE OF WORK TO BE COMPLETED BY ALL SUBCONTRACTORS/SUBCONSULTANTS ON THE PROJECT.**

Name, Address and Phone Number	(Check all Applicable Categories)			DOLLAR AMOUNT OR PERCENTAGE OF WORK					
	Non-SBE	M/WBE Minority/Women Business	SBE Small Business	Black	Hispanic	Women	Caucasian	Other (Please Specify)	
1. Unpurchased scope; credit for demolition of interior door	<input checked="" type="checkbox"/>	<input type="checkbox"/>	<input type="checkbox"/>	_____	_____	_____	_____	-\$1,800.00	
2.	<input type="checkbox"/>	<input type="checkbox"/>	<input type="checkbox"/>	_____	_____	_____	_____	_____	
3.	<input type="checkbox"/>	<input type="checkbox"/>	<input type="checkbox"/>	_____	_____	_____	_____	_____	
4.	<input type="checkbox"/>	<input type="checkbox"/>	<input type="checkbox"/>	_____	_____	_____	_____	_____	
5.	<input type="checkbox"/>	<input type="checkbox"/>	<input type="checkbox"/>	_____	_____	_____	_____	_____	
(Please use additional sheets if necessary)				<b>Total</b>	_____	_____	\$11,500.00	\$67,674.07	\$14,660.00
Total Bid Price \$ <u>\$93,834.07</u>				Total SBE - M/WBE Participation <u>79,174.07 / 84%</u>					

I hereby certify that the above information is accurate to the best of my knowledge: \_\_\_\_\_  
B. Allen  
Signature Vice President  
\_\_\_\_\_ \_\_\_\_\_  
Signature Title

- Note:**
1. The amount listed on this form for a Subcontractor/subconsultant must be supported by price or percentage listed on the properly executed Schedule 2 or attached signed proposal.
  2. Firms may be certified by Palm Beach County as an SBE and/or an M/WBE. If firms are certified as both an SBE and/or M/WBE, please indicate the dollar amount under the appropriate category.
  3. Modification of this form is not permitted and will be rejected upon submittal.

**OEBO LETTER OF INTENT – SCHEDULE 2**

A completed Schedule 2 is a binding document between the Prime Contractor/consultant and a Subcontractor/subconsultant (for any tier) and should be treated as such. The Schedule 2 shall contain bolded language indicating that by signing the Schedule 2, both parties recognize this Schedule as a binding document. All subcontractors/subconsultants, including any tiered subcontractors/subconsultants, must properly execute this document. Each properly executed Schedule 2 must be submitted with the bid/proposal.

SOLICITATION/PROJECT NUMBER: 20149

SOLICITATION/PROJECT NAME: SFWMD B2 Bldg. 3rd Floor Renovation for PBSO

Name of Prime: Robling Architecture Construction, Inc.

**(Check box(s) that apply)**

SBE    WBE    MBE    M/WBE    Non-S/M/WBE   Date of Palm Beach County Certification (if applicable): Exp. 3/18/2023

The undersigned affirms they are the following (select one from each column):

**Column 1**

**Column 2**

Male    Female                       African-American/Black    Asian American    Caucasian American  
 Hispanic American                       Native American

**S/M/WBE PARTICIPATION** – S/M/WBE Primes must document all work to be performed by their own work force on this form. Failure to submit a properly executed Schedule 2 for any S/M/WBE participation may result in that participation not being counted. Specify in detail, the scope of work to be performed or items supplied with the dollar amount and/or percentage for each work item. S/M/WBE credit will only be given for the areas in which the S/M/WBE is certified. A detailed proposal may be attached to a properly executed Schedule 2.

Line Item	Item Description	Unit Price	Qty./Units	Contingencies/ Allowances	Total Price/Percentage
	Electrical	1	LS		, \$53,164.00

The undersigned Subcontractor/subconsultant is prepared to self-perform the above-described work in conjunction with the aforementioned project at the following total price or percentage: \$53,164.00

If the undersigned intends to subcontract any portion of this work to another Subcontractor/subconsultant, please list the business name and the amount below accompanied by a separate properly executed Schedule 2.

n/a

Name of 2<sup>nd</sup>/3<sup>rd</sup> tier Subcontractor/subconsultant \_\_\_\_\_ Price or Percentage: \_\_\_\_\_

Robling Architecture Construction, Inc.  
 Print name of Prime  
 By:   
 Authorized Signature  
Damon A Robling  
 Print name  
President  
 Title  
 Date: 8/26/2020

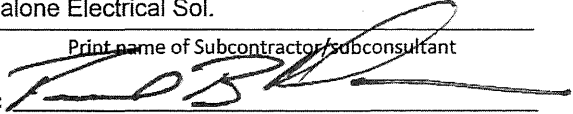
Malone Electrical Sol.  
 Print name of Subcontractor/subconsultant  
 By:   
 Authorized Signature  
Raymond B. murdock  
 Print name  
President  
 Title  
 Date: 8/26/2020

**OEBO LETTER OF INTENT – SCHEDULE 2**

A completed Schedule 2 is a binding document between the Prime Contractor/consultant and a Subcontractor/subconsultant (for any tier) and should be treated as such. The Schedule 2 shall contain bolded language indicating that by signing the Schedule 2, both parties recognize this Schedule as a binding document. All subcontractors/subconsultants, including any tiered subcontractors/subconsultants, must properly execute this document. Each properly executed Schedule 2 must be submitted with the bid/proposal.

SOLICITATION/PROJECT NUMBER: 20149

SOLICITATION/PROJECT NAME: SFWMD B2 Bldg. 3rd Floor Renovation for PBSO

Name of Prime: Robling Architecture Construction, Inc.

**(Check box(s) that apply)**

SBE    WBE    MBE    M/WBE    Non-S/M/WBE   Date of Palm Beach County Certification (if applicable): 2/8/18 - 2/7/21

The undersigned affirms they are the following (select one from each column):

**Column 1**

**Column 2**

Male    Female

African-American/Black    Asian American    Caucasian American

Hispanic American    Native American

**S/M/WBE PARTICIPATION** – S/M/WBE Primes must document all work to be performed by their own work force on this form. Failure to submit a properly executed Schedule 2 for any S/M/WBE participation may result in that participation not being counted. Specify in detail, the scope of work to be performed or items supplied with the dollar amount and/or percentage for each work item. S/M/WBE credit will only be given for the areas in which the S/M/WBE is certified. A detailed proposal may be attached to a properly executed Schedule 2.

Line Item	Item Description	Unit Price	Qty./Units	Contingencies/ Allowances	Total Price/Percentage
	HVAC	1	LS		\$14,510.07

The undersigned Subcontractor/subconsultant is prepared to self-perform the above-described work in conjunction with the aforementioned project at the following total price or percentage: \$14,510.07

If the undersigned intends to subcontract any portion of this work to another Subcontractor/subconsultant, please list the business name and the amount below accompanied by a separate properly executed Schedule 2.

\_\_\_\_\_ Price or Percentage: \_\_\_\_\_

Name of 2<sup>nd</sup>/3<sup>rd</sup> tier Subcontractor/subconsultant

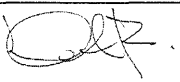
Robling Architecture Construction, Inc.  
 Print name of Prime  
 By:   
 Authorized Signature  
Damon A Robling  
 Print name  
President  
 Title  
 Date: 8/26/2020

The Airtex Corp.  
 Print name of Subcontractor/subconsultant  
 By: Daniela Narango  
 Authorized Signature  
Daniela Narango  
 Print name  
V.P.  
 Title  
 Date: 8/26/2020

**OEBO LETTER OF INTENT – SCHEDULE 2**

A completed Schedule 2 is a binding document between the Prime Contractor/consultant and a Subcontractor/subconsultant (for any tier) and should be treated as such. The Schedule 2 shall contain bolded language indicating that by signing the Schedule 2, both parties recognize this Schedule as a binding document. All subcontractors/subconsultants, including any tiered subcontractors/subconsultants, must properly execute this document. Each properly executed Schedule 2 must be submitted with the bid/proposal.

SOLICITATION/PROJECT NUMBER: 20149

SOLICITATION/PROJECT NAME: SFWMD B2 Bldg. 3rd Floor Renovation for PBSO

Name of Prime: Robling Architecture Construction, Inc.

**(Check box(s) that apply)**

SBE WBE MBE M/WBE Non-S/M/WBE Date of Palm Beach County Certification (if applicable): 10/3/19 - 10/2/22

The undersigned affirms they are the following (select one from each column):

**Column 1**

**Column 2**

Male Female

African-American/Black Asian American Caucasian American

Hispanic American Native American

**S/M/WBE PARTICIPATION** – S/M/WBE Primes must document all work to be performed by their own work force on this form. Failure to submit a properly executed Schedule 2 for any S/M/WBE participation may result in that participation not being counted. Specify in detail, the scope of work to be performed or items supplied with the dollar amount and/or percentage for each work item. S/M/WBE credit will only be given for the areas in which the S/M/WBE is certified. A detailed proposal may be attached to a properly executed Schedule 2.

Line Item	Item Description	Unit Price	Qty./Units	Contingencies/ Allowances	Total Price/Percentage
	Card Access	1	LS		\$11,500

The undersigned Subcontractor/subconsultant is prepared to self-perform the above-described work in conjunction with the aforementioned project at the following total price or percentage: \_\_\_\_\_

**If the undersigned intends to subcontract any portion of this work to another Subcontractor/subconsultant, please list the business name and the amount below accompanied by a separate properly executed Schedule 2.**

\_\_\_\_\_ Price or Percentage: \_\_\_\_\_

**Name of 2<sup>nd</sup>/3<sup>rd</sup> tier Subcontractor/subconsultant**

Robling Architecture Construction, Inc.

Print name of Prime

By: 

Authorized Signature

Damon A Robling

Print name

President

Title

Date: 8/26/2020

Protect Video, Inc.

Print name of Subcontractor/subconsultant

By: 

Authorized Signature

Shad DiMaria

Print name

President

Title

Date: 8/26/2020

**OEBO LETTER OF INTENT – SCHEDULE 2**

A completed Schedule 2 is a binding document between the Prime Contractor/consultant and a Subcontractor/subconsultant (for any tier) and should be treated as such. The Schedule 2 shall contain bolded language indicating that by signing the Schedule 2, both parties recognize this Schedule as a binding document. All subcontractors/subconsultants, including any tiered subcontractors/subconsultants, must properly execute this document. Each properly executed Schedule 2 must be submitted with the bid/proposal.

SOLICITATION/PROJECT NUMBER: 20149  
 SOLICITATION/PROJECT NAME: SFWMD B2 Bldg. 3rd Floor Renovation for PBSO

Name of Prime: Robling Architecture Construction, Inc.

**(Check box(s) that apply)**

SBE WBE MBE M/WBE Non-S/M/WBE Date of Palm Beach County Certification (if applicable): \_\_\_\_\_.

The undersigned affirms they are the following (select one from each column):

**Column 1**

Male Female

**Column 2**

African-American/Black Asian American Caucasian American  
Hispanic American Native American

**S/M/WBE PARTICIPATION** – S/M/WBE Primes must document all work to be performed by their own work force on this form. Failure to submit a properly executed Schedule 2 for any S/M/WBE participation may result in that participation not being counted. Specify in detail, the scope of work to be performed or items supplied with the dollar amount and/or percentage for each work item. S/M/WBE credit will only be given for the areas in which the S/M/WBE is certified. A detailed proposal may be attached to a properly executed Schedule 2.

Line Item	Item Description	Unit Price	Qty./Units	Contingencies/ Allowances	Total Price/Percentage
	Fire Sprinkler	1	LS		650.00

The undersigned Subcontractor/subconsultant is prepared to self-perform the above-described work in conjunction with the aforementioned project at the following total price or percentage: 650.00

**If the undersigned intends to subcontract any portion of this work to another Subcontractor/subconsultant, please list the business name and the amount below accompanied by a separate properly executed Schedule 2.**

\_\_\_\_\_ Price or Percentage: \_\_\_\_\_  
 Name of 2<sup>nd</sup>/3<sup>rd</sup> tier Subcontractor/subconsultant

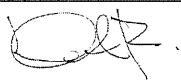
Robling Architecture Construction, Inc.  
 Print name of Prime  
 By:   
 \_\_\_\_\_  
 Authorized Signature  
Damon A Robling  
 Print name  
President  
 Title  
 Date: 8/26/2020

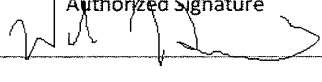
Brigade Fire Protection  
 Print name of Subcontractor/subconsultant  
 By: Wil Holland  
 \_\_\_\_\_  
 Authorized Signature  
  
 Print name  
President  
 Title  
 Date: 8/26/2020

**OEBO LETTER OF INTENT – SCHEDULE 2**

A completed Schedule 2 is a binding document between the Prime Contractor/consultant and a Subcontractor/subconsultant (for any tier) and should be treated as such. The Schedule 2 shall contain bolded language indicating that by signing the Schedule 2, both parties recognize this Schedule as a binding document. All subcontractors/subconsultants, including any tiered subcontractors/subconsultants, must properly execute this document. Each properly executed Schedule 2 must be submitted with the bid/proposal.

SOLICITATION/PROJECT NUMBER: 20149

SOLICITATION/PROJECT NAME: SFWMD B2 Bldg. 3rd Floor Renovation for PBSO

Name of Prime: Robling Architecture Construction, Inc.

**(Check box(s) that apply)**

SBE WBE MBE M/WBE Non-S/M/WBE Date of Palm Beach County Certification (if applicable): \_\_\_\_\_.

The undersigned affirms they are the following (select one from each column):

**Column 1**

**Column 2**

Male Female African-American/Black Asian American Caucasian American  
Hispanic American Native American

**S/M/WBE PARTICIPATION** – S/M/WBE Primes must document all work to be performed by their own work force on this form. Failure to submit a properly executed Schedule 2 for any S/M/WBE participation may result in that participation not being counted. Specify in detail, the scope of work to be performed or items supplied with the dollar amount and/or percentage for each work item. S/M/WBE credit will only be given for the areas in which the S/M/WBE is certified. A detailed proposal may be attached to a properly executed Schedule 2.

Line Item	Item Description	Unit Price	Qty./Units	Contingencies/ Allowances	Total Price/Percentage
	Fire Alarm	1	LS		\$15,810.00

The undersigned Subcontractor/subconsultant is prepared to self-perform the above-described work in conjunction with the aforementioned project at the following total price or percentage: \$15,810.00

**If the undersigned intends to subcontract any portion of this work to another Subcontractor/subconsultant, please list the business name and the amount below accompanied by a separate properly executed Schedule 2.**

\_\_\_\_\_ Price or Percentage: \_\_\_\_\_

**Name of 2<sup>nd</sup>/3<sup>rd</sup> tier Subcontractor/subconsultant**

Robling Architecture Construction, Inc.

Print name of Prime 

By: \_\_\_\_\_  
Authorized Signature

Damon A Robling  
Print name

President  
Title

Date: 8/26/2020

Knight Fire & Security

Print name of Subcontractor/subconsultant

By: \_\_\_\_\_

Jeff Knight  
Print name

President  
Title

Date: 8/26/2020



PALM BEACH COUNTY

CONSTRUCTION CHANGE PROPOSAL (CCP)

TO: Palm Beach County  
2633 Vista Parkway  
West Palm Beach, FL 33411

CCP NUMBER: 04

DATE: 8/26/2020

ATTENTION: Jim Daley

PROJECT NAME: SFWMD B2 Bldg 3rd Floor Improv.

PROJECT NUMBER: 20149

REFERENCE:

CONTRACT NUMBER: R2016-0762 (R2020-0519)

We propose to accomplish the MODIFICATIONS identified in FIELD BULLETIN FB #N/A and as described herein. Except as modified below, the original contract and all prior amendments shall remain in full force and effect.

DESCRIPTION:

Furnish and install (5) Schlage cylindrical locks at modular furniture doors (modular doors were supplied by others).

Furnish and install (5) electric strikes

Furnish and install delayed egress hardware at (3) modular furniture doors (modular doors were supplied by others). These doors will be modified (stiffened) to accommodate the exit device hardware.

Furnish and install

PROPOSED CONTRACT PRICE CHANGE ( INCREASE ) \$ 18648.16

PROPOSED CONTRACT TIME CHANGE ( N/A ) 0 days

PROPOSED NEW SUBSTANTIAL COMPLETION \_\_\_\_\_ date

FROM: Robling Architecture Construction, Inc.  
CONTRACTOR

DISTRIBUTION:

SIGNED:

DATE: 8/26/2020

PALM BEACH COUNTY

CCP CALCULATION SHEET

TO: Palm Beach County  
 2633 Vista Parkway  
 West Palm Beach, FL 33411

CCP NUMBER: 04  
 DATE: 8/26/2020  
 PROJECT NAME: SFWMD B2 Bldg 3rd Floor Improv.  
 PROJECT NUMBER: 20149  
 CONTRACT NUMBER:

ATTENTION: Jim Daley

REFERENCE:

Item	Description	Labor Unit Cost	Labor Qty	Labor Total	Material Unit Cost	Material Qty	Material Total	Total Cost / Subcontractor Cost
1	Robling, Overhead & Profit (5%)							\$ 888.00
2	Robling, Furnish & Install electric strikes for (5) modular furniture doors							\$ 1,225.16
3	Robling, furnish and install laminated panels to accommodate delayed egress exit devices at (3) modular doors							\$ 480.00
4	Atlantic Door, furnish delayed egress hardware for (3) modular furniture doors. Furnish Schlage cylindrical locks for (5) modular furniture doors							\$ 16,055.00
Total								18,648.16

CCP-04

CCP-04



**INVOICE**

1800 N. FLORIDA MANGO RD.  
WEST PALM BEACH, FL 33409-6406  
www.grainger.com

GRAINGER ACCOUNT NUMBER 877007401  
INVOICE NUMBER 9610956790  
INVOICE DATE 08/05/2020  
**NO AMOUNT DUE**

SHIP TO

ROBLING ARCHITECTURE CONSTRUCTION  
101 Walker Ave  
Greenacres FL 33463-3343

PO NUMBER: 20149  
CALLER: BRIAN ALLEN  
CUSTOMER PHONE: 5616496705  
ORDER NUMBER: 1390089406  
INCO TERMS: FOB ORIGIN

BILL TO

ROBLING ARCHITECTURE CONSTRUCTION  
101 WALKER AVE  
GREENACRES FL 33463-3343

Pay invoices online at:  
[www.grainger.com/invoicing](http://www.grainger.com/invoicing)  
Sign up for paperless invoicing at:  
[www.grainger.com/paperlessinvoicing](http://www.grainger.com/paperlessinvoicing)

**THANK YOU!** FE NUMBER 36-1150280  
FOR QUESTIONS ABOUT THIS INVOICE OR ACCOUNT CALL **1-800-472-4643**

PO LINE #	ITEM #	DESCRIPTION	QUANTITY	UNIT PRICE	TOTAL
1	28XP77	ELECTRIC STRIKE, 1500 LB., METAL MANUFACTURER # 3234-24DC-26D  Delivery #: 6478336617 Date: 08/05/2020 Carrier: UPS GROUND No: of Pkgs: 1 Wt: 3.000 Trk #: 1Z5413RY0316899112 SHIPPED FROM: DC BORDENTOWN 010 400 BORDENTOWN-HEDDING RD, BORDENTOWN, NJ 08505	5	149.50	747.50

THIS PURCHASE IS GOVERNED EXCLUSIVELY BY GRAINGER'S TERMS OF SALE, INCLUDING: (I) DISPUTE RESOLUTION REMEDIES, AND (II) CERTAIN WARRANTY AND DAMAGES LIMITATIONS AND DISCLAIMERS IN EFFECT AT THE TIME OF THE ORDER, WHICH ARE INCORPORATED BY REFERENCE HEREIN. GRAINGER'S TERMS OF SALE ARE AVAILABLE AT [WWW.GRAINGER.COM](http://WWW.GRAINGER.COM) PRODUCT RETURN INSTRUCTIONS ARE AVAILABLE AT [WWW.GRAINGER.COM/RETURNS](http://WWW.GRAINGER.COM/RETURNS)

INVOICE SUB TOTAL	747.50
SHIPPING	12.83
TAX	52.33
CR. CARD OR CASH RECEIVED	812.66

These items are sold for domestic consumption. If exported, purchaser assumes full responsibility for compliance with US export controls. Diversion contrary to US law prohibited.  
Reprint

material cost only

NO PAYMENT DUE -- PAYMENT TERMS American Exp. THIS INVOICE FOR YOUR RECORDS. **AMOUNT DUE \$0.00**

**NO PAYMENT DUE - THIS INVOICE FOR YOUR RECORDS**

Robling labor to install (cut, grind & file smooth modular furniture frame to accommodate electric strikes

Labor: 1.5 hrs x \$55 x 5 doors: \$412.50

Material: \$812.66  
Labor: \$412.50

**Total: \$1,225.16**

# MICA INNOVATIONS

7233 Southern Blvd A2  
West Palm Beach, FL 33413

Phone: 561-687-0807  
Fax: 561-687-4254  
Email: micainnovations@msn.com

## Proposal

DATE: 08/19/2020

TO: Robling Architecture Construction, Inc.

JOB: Door Panels

---

Mica Innovations will provide all material and labor to Fabricate Door Panels.

**TOTAL \$150.00**

← Fabrication of panels only

Fabricate ( 3 ) Plywood Door Panels with Matte Black Plastic Laminate  
Panels are to be Laminated on all four edges and one face  
Each Panel will be 36 1/4" long x 12" x 3/8" thick

Panels are to be picked up at our shop

35-1/4"

Installation by Robling;  
Cut open door to install wood blocking/bracing, route electric wiring, install laminated panel on face of door.  
2 hrs x \$55 x 3 doors = \$330

Subtotal .....	150.00
Installation.....	N/A
Shop drawings.....	N/A
TOTAL .....	150.00

Prices are subject to change and may be re-evaluated if not accepted within 30 days from Proposal Date. No alterations or additional work shall be performed without further evaluation

By Mica Innovations

ACCEPTED DATE: \_\_\_\_\_ APPROVED DATE 8/20/2020

Company Name: \_\_\_\_\_ By: B. Fall

Robling Arch. Construction

Material cost: \$150.00  
Labor to Install: \$330.00

Total: \$480.00

The cost for the locksets will be \$185.00 tax included each \$925.00 tax inc. material  
AL80JD 626 Saturn lever LESS FINAL CORE.

Schlage Cyl locks for (5)  
modular doors

The cost for EACH door on the delayed egress exit device system will be \$4,590.00 tax inc. \$13,770.00 tax inc. material.

Each opening includes:

- 1 ea. door loop
- 1 ea. CX99 EO delayed egress exit device
- 1 ea. E996L (elect unlocking trim)
- 1 ea. Power supply for above.

Delayed egress hardware  
for (3) modular doors

As discussed with Victor, I can get this material from a warehouse however, I have confirmed that the exit devices with the EL trim is for 1 3/4" thick doors. The doors will have to be modified for this thickness. Furthermore, the doors will have to be reinforced for the trim/thru bolts at both the latch side (approx. 6 x 12 block) and hinge side (approx. 4 x 4 block) for proper reinforcing. The strike plate will need to be on a modified strike block set to the existing frame, I cannot find anything for that modification.

The system for the delayed egress will require 120V to where the power supply will be installed. these exit devices require a regulated power supply that is included in the above price. The exit device (Delayed egress portion) will require 18 gauge wires for up to 50' away from the power supply (1 amp reqd power) and the trim will probably be ok with 20 gauge but I have a larger door loop (3/8") for larger wires. The power supply will be required to hook into the fire alarm, I have the aux fire alarm board included in the power supply for this hookup) the card readers, wiring and conduit will be by others.

Operation:

Doors normally closed and locked. Egress side equipped with delayed egress exit device hardware. Pushing exit device bar will initiate a 15 second delay alarm before allowing egress. Presenting credentials from egress (push bar side) shunts alarm allowing immediate egress. Presenting credentials from secure side unlocks Lever trim and shunts alarm allowing immediate ingress. Delayed egress automatically rearms after timer. Delayed egress function tied into fire alarm shunting alarm allowing immediate egress upon alarm.

\$14,595.00 tax included for material.

Scott Renstrom



Atlantic Doors and Hardware, Inc.  
4601 10th Avenue North  
Lake Worth, FL 33463  
(561) 968-2228

(5) Cyl. locks: \$925.00  
(3) Del. egress: \$13,770.00  
Installation: \$1,360.00

**Total: \$16,055**

**OEBO SCHEDULE 1**

**LIST OF PROPOSED CONTRACTOR/CONSULTANT AND SUBCONTRACTOR/SUBCONSULTANT PARTICIPATION**

SOLICITATION/PROJECT/BID NAME: SFWMD B2 Bldg. 3rd Floor Renovation for PBSO  
 NAME OF PRIME RESPONDENT/BIDDER: Robling Architecture Construction, Inc.  
 CONTACT PERSON: Brian Allen  
 SOLICITATION OPENING/SUBMITTAL DATE: \_\_\_\_\_

SOLICITATION/PROJECT/BID No.: 20149  
 ADDRESS: 101 Walker Avenue, Greenacres, FL 33463  
 PHONE NO.: 561-649-6705 E-MAIL: ballen@robling.com  
 DEPARTMENT: Capital Improvements Division

**PLEASE LIST THE DOLLAR AMOUNT OR PERCENTAGE OF WORK TO BE COMPLETED BY THE PRIME CONTRACTOR/CONSULTANT ON THIS PROJECT. PLEASE ALSO LIST THE DOLLAR AMOUNT OR PERCENTAGE OF WORK TO BE COMPLETED BY ALL SUBCONTRACTORS/SUBCONSULTANTS ON THE PROJECT.**

Name, Address and Phone Number	(Check all Applicable Categories)			DOLLAR AMOUNT OR PERCENTAGE OF WORK					
	Non-SBE	M/WBE Minority/Women Business	SBE Small Business	Black	Hispanic	Women	Caucasian	Other (Please Specify)	
1. Robling Architecture Construction, Inc. 101 Walker Avenue, Greenacres, FL 33463 T: 561-649-6705 VC0000103416	<input type="checkbox"/>	<input type="checkbox"/>	<input checked="" type="checkbox"/>	_____	_____	_____	\$2,593.16	_____	
2. Atlantic Door & Hardware 4601 10th Ave N, Lake Worth 33463 561-968-2228 ID No. ATLA0103	<input checked="" type="checkbox"/>	<input type="checkbox"/>	<input type="checkbox"/>	_____	_____	_____	_____	\$16,055.00	
3.	<input type="checkbox"/>	<input type="checkbox"/>	<input type="checkbox"/>	_____	_____	_____	_____	_____	
4.	<input type="checkbox"/>	<input type="checkbox"/>	<input type="checkbox"/>	_____	_____	_____	_____	_____	
5.	<input type="checkbox"/>	<input type="checkbox"/>	<input type="checkbox"/>	_____	_____	_____	_____	_____	
(Please use additional sheets if necessary)							Total	\$2,593.16	\$16,055.00
Total Bid Price \$ <u>\$18,648.16</u>		Total SBE - M/WBE Participation			<u>2593.16 / 14%</u>				

I hereby certify that the above information is accurate to the best of my knowledge: \_\_\_\_\_  
 Signature: B. Allen Title: Vice President

- Note:**
- The amount listed on this form for a Subcontractor/subconsultant must be supported by price or percentage listed on the properly executed Schedule 2 or attached signed proposal.
  - Firms may be certified by Palm Beach County as an SBE and/or an M/WBE. If firms are certified as both an SBE and/or M/WBE, please indicate the dollar amount under the appropriate category.
  - Modification of this form is not permitted and will be rejected upon submittal.

A completed Schedule 2 is a binding document between the Prime Contractor/consultant and a Subcontractor/subconsultant (for any tier) and should be treated as such. The Schedule 2 shall contain bolded language indicating that by signing the Schedule 2, both parties recognize this Schedule as a binding document. All subcontractors/subconsultants, including any tiered subcontractors/subconsultants, must properly execute this document. Each properly executed Schedule 2 must be submitted with the bid/proposal.

SOLICITATION/PROJECT NUMBER: 20149

SOLICITATION/PROJECT NAME: SFWMD B2 Bldg. 3rd Floor Renovation for PBSO

Name of Prime: Robling Architecture Construction, Inc.

(Check box(s) that apply)

SBE WBE MBE M/WBE Non-S/M/WBE Date of Palm Beach County Certification (if applicable): Exp. 6/26/2021

The undersigned affirms they are the following (select one from each column):

Column 1

Column 2

Male Female African-American/Black Asian American Caucasian American Hispanic American Native American

S/M/WBE PARTICIPATION – S/M/WBE Primes must document all work to be performed by their own work force on this form. Failure to submit a properly executed Schedule 2 for any S/M/WBE participation may result in that participation not being counted. Specify in detail, the scope of work to be performed or items supplied with the dollar amount and/or percentage for each work item. S/M/WBE credit will only be given for the areas in which the S/M/WBE is certified. A detailed proposal may be attached to a properly executed Schedule 2.

Table with 6 columns: Line Item, Item Description, Unit Price, Qty./Units, Contingencies/Allowances, Total Price/Percentage. Rows include Construction Management OH&P, Door Hardware, and Modify Doors.

The undersigned Subcontractor/subconsultant is prepared to self-perform the above-described work in conjunction with the aforementioned project at the following total price or percentage: \$2,593.16

If the undersigned intends to subcontract any portion of this work to another Subcontractor/subconsultant, please list the business name and the amount below accompanied by a separate properly executed Schedule 2.

Name of 2nd/3rd tier Subcontractor/subconsultant

Price or Percentage:

Robling Architecture Construction, Inc.

Print name of Prime

By: [Signature]

Authorized Signature

Damon A Robling

Print name

President

Title

Date: 9/3/2020

Robling Architecture Construction, Inc.

Print name of Subcontractor/subconsultant

By: [Signature]

Authorized Signature

Brian Allen

Print name

Vice President

Title

Date: 9/3/2020

A completed Schedule 2 is a binding document between the Prime Contractor/consultant and a Subcontractor/subconsultant (for any tier) and should be treated as such. The Schedule 2 shall contain bolded language indicating that by signing the Schedule 2, both parties recognize this Schedule as a binding document. All subcontractors/subconsultants, including any tiered subcontractors/subconsultants, must properly execute this document. Each properly executed Schedule 2 must be submitted with the bid/proposal.

SOLICITATION/PROJECT NUMBER: 20149

SOLICITATION/PROJECT NAME: SFWMD B2 Bldg. 3rd Floor Renovation for PBSO

Name of Prime: Robling Architecture Construction, Inc.

**(Check box(s) that apply)**

SBE WBE MBE M/WBE Non-S/M/WBE Date of Palm Beach County Certification (if applicable): \_\_\_\_\_

The undersigned affirms they are the following (select one from each column):

**Column 1**

**Column 2**

Male Female

African-American/Black Asian American Caucasian American

Hispanic American Native American

**S/M/WBE PARTICIPATION** – S/M/WBE Primes must document all work to be performed by their own work force on this form. Failure to submit a properly executed Schedule 2 for any S/M/WBE participation may result in that participation not being counted. Specify in detail, the scope of work to be performed or items supplied with the dollar amount and/or percentage for each work item. S/M/WBE credit will only be given for the areas in which the S/M/WBE is certified. A detailed proposal may be attached to a properly executed Schedule 2.

Line Item	Item Description	Unit Price	Qty./Units	Contingencies/ Allowances	Total Price/Percentage
	Door Hardware				\$16,055.00

The undersigned Subcontractor/subconsultant is prepared to self-perform the above-described work in conjunction with the aforementioned project at the following total price or percentage: \$16,055.00

If the undersigned intends to subcontract any portion of this work to another Subcontractor/subconsultant, please list the business name and the amount below accompanied by a separate properly executed Schedule 2.

\_\_\_\_\_ Price or Percentage: \_\_\_\_\_

Name of 2<sup>nd</sup>/3<sup>rd</sup> tier Subcontractor/subconsultant

Robling Architecture Construction, Inc.

Print name of Prime

By:   
Authorized Signature

Damon A Robling

Print name

President

Title

Date: 9/3/2020

Atlantic Door & Hardware

Print name of Subcontractor/subconsultant

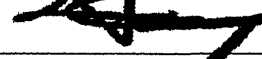
By:   
Authorized Signature

Sean Wiley

Print name

Vice Pres.

Title

Date: 9/3/2020



September 8, 2020

Mr. Jim Daley  
Facilities Development & Operations Department  
Palm Beach County Capital Improvements Division  
2633 Vista Parkway  
West Palm Beach, Florida 33411

Re: PBC PBSO at SFWMD B2 Building 3<sup>rd</sup> Floor Renovations  
PBC Project No. 20149  
CCP No. 5.

Dear Mr. Daley:

Colomé & Associates, Inc., architect has reviewed Robling Architecture Construction, Inc., request for approval of Construction Change Proposal No. 5 for work described with in Field Bulletin No. 1 and work related to the installation of electrical occupancy sensors per RFI 1 response for the above referenced project.

We have determined to the best of our ability that the added amount of fifteen thousand six hundred eight and twenty-five (\$15,608.25) cents meet the industry's standards for the scope of work specified per Field Bulletin No. 1 and RFI 1 response.

There are no days of time extension to the contract associated with CCP No. 5.

If you should have any questions, please do not hesitate to contact me.

Sincerely,



Joe O. Colomé  
Senior Project Manager

CC: Elizabeth Colomé

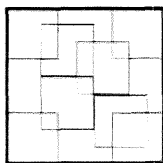

**Colomé & Associates, Inc.**

Florida Registration AA0001439

Architecture □ Planning □ Interiors

530 24th Street □ West Palm Beach, Florida 33407 □ Telephone: (561) 833-9147 □ Facsimile: (561) 833-9356 □ E-mail: colome@colome-arch.net



PALM BEACH COUNTY

PBSO AT SFWMD 3<sup>RD</sup> FLOOR BUILDING RENOVATIONS

FIELD BULLETIN (FB) #01

TO: **Robling Architecture Construction, Inc.**  
101 Walker Avenue  
Greenacres, Florida 33463

ATTENTION: **Mr. Brian Allen**

REFERENCE: **PBSO Owner Plan Revisions**

FB NUMBER: 01

DATE: 08/07/2020

PROJECT NAME: PBC PBSO at SFWMD 3<sup>rd</sup> Floor Building  
Renovations

PROJECT NUMBER: #20149

CONTRACT NUMBER: R2016-0762 (R2020-0519)

THIS BULLETIN IS NOT A CHANGE IN THE ABOVE CONTRACT NOR AN AUTHORIZATION TO THE CONTRACTOR TO PERFORM WORK, OTHER THAN CONTRACT WORK, OR TO STOP OR SUSPEND WORK UNLESS SPECIFICALLY AUTHORIZED BY THIS BULLETIN. However, it covers certain PROPOSED MODIFICATIONS to the work covered by said contract.

CAUSE: As required by PBC PBSO, provide cost values for the owner plan revisions. This work was not in the original scope of work and was submitted as a permit revision.

DESCRIPTION: Provide cost values including labor and material for Owner Permit Revisions. (See attached Revised Plans).

NOTE: THE REVISED DWGS. ASSOCIATED WITH THIS FB #01 ARE INCLUDED AT THE END OF THIS CCP PACKAGE.

NOTE: The Contractor shall submit, within 21 days of receipt of this Bulletin, a CONSTRUCTION CHANGE PROPOSAL # next in detailed form, for the above referenced project.

ORIGINATOR:

Colome' & Associates, Inc.  
FIRM

  
SIGNATURE

08/07/2020  
DATE

REMARKS: \_\_\_\_\_  
\_\_\_\_\_  
\_\_\_\_\_

DISTRIBUTION: Owner's Project Manager  
Owner's Field Representative

COLOME & ASSOCIATES, INC.  
DESIGN PROFESSIONAL

08/07/2020  
DATE

PALM BEACH COUNTY

CONSTRUCTION CHANGE PROPOSAL (CCP)

TO: Palm Beach County  
2633 Vista Parkway  
West Palm Beach, FL 33411

CCP NUMBER: 05

DATE: 9/2/2020

ATTENTION: Jim Daley

PROJECT NAME: SFWMD B2 Bldg 3rd Floor Improv.

PROJECT NUMBER: 20149

REFERENCE:

CONTRACT NUMBER: R2016-0762 (R2020-0519)

We propose to accomplish the MODIFICATIONS identified in FIELD BULLETIN FB # 1 and as described herein. Except as modified below, the original contract and all prior amendments shall remain in full force and effect.

DESCRIPTION:

Install (18) ceiling mounted lighting occupant sensors, per drawing E2, Rev1 5/29/2020.  
This work was not included on the GMP bid documents.

PROPOSED CONTRACT PRICE CHANGE ( INCREASE ) \$ 15608.25

PROPOSED CONTRACT TIME CHANGE ( N/A ) days

PROPOSED NEW SUBSTANTIAL COMPLETION \_\_\_\_\_ date

FROM: Robling Architecture Construction, Inc.  
CONTRACTOR

DISTRIBUTION:

SIGNED:

DATE:

PALM BEACH COUNTY

CCP CALCULATION SHEET

TO: Palm Beach County  
 2633 Vista Parkway  
 West Palm Beach, FL 33411

CCP NUMBER: 05  
 DATE: 9/2/2020  
 PROJECT NAME: SFWMD B2 Bldg 3rd Floor Improv.  
 PROJECT NUMBER: 20149  
 CONTRACT NUMBER:

ATTENTION: Jim Daley

REFERENCE:

Item	Description	Labor Unit Cost	Labor Qty	Labor Total	Material Unit Cost	Material Qty	Material Total	Total Cost / Subcontractor Cost
1	Malone Electrical Solutions							\$ 14,865.00
2	Robling, 5% OH&P							\$ 743.25
Total								15,608.25

CCP-05

CCP-05

# SFWMD B-2 3RD FLOOR OCCUPANCY SENSOR LAY OUT PER PRICING

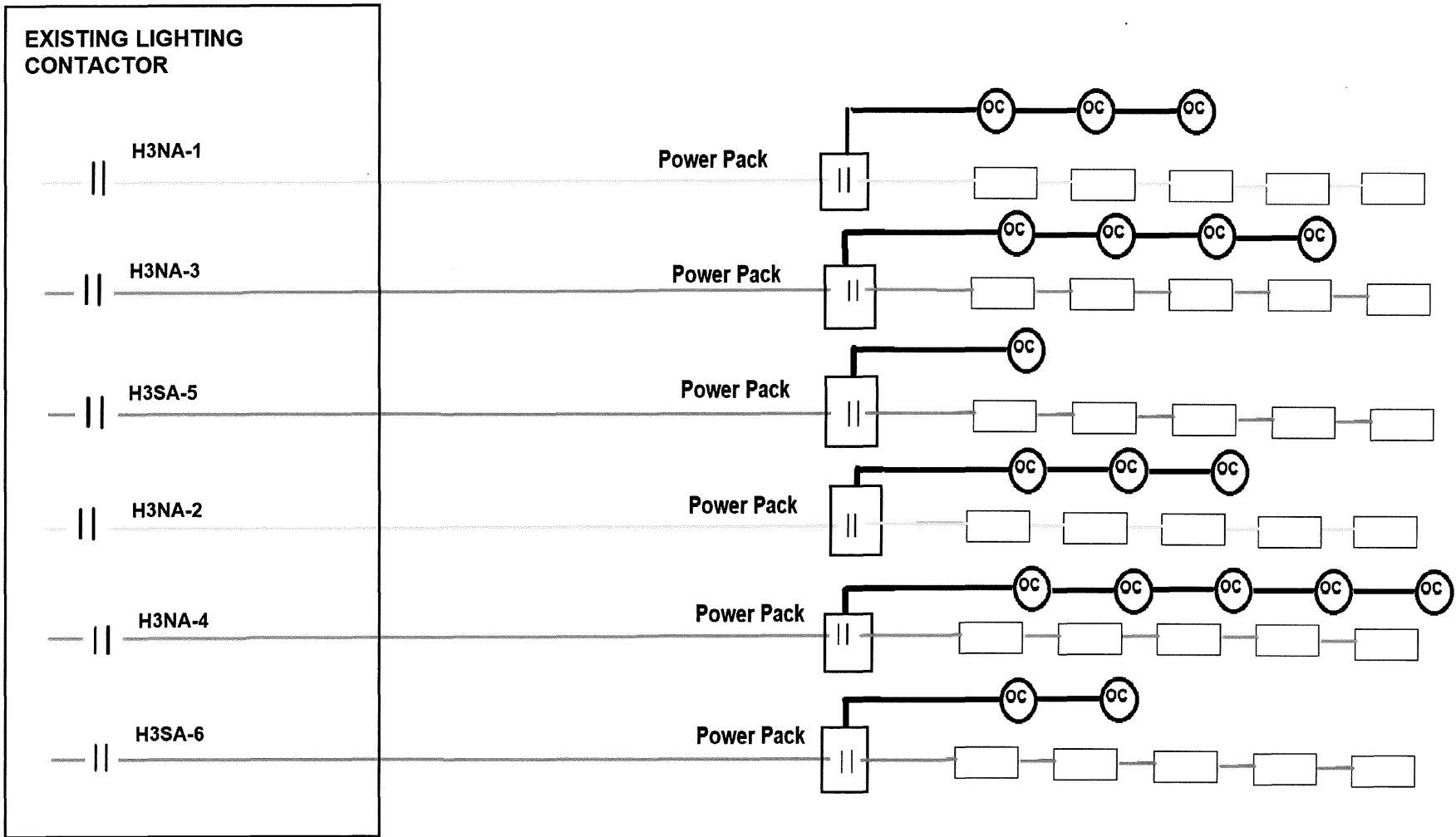

REFER TO SHEET E1.06 FOR CONTINUATION

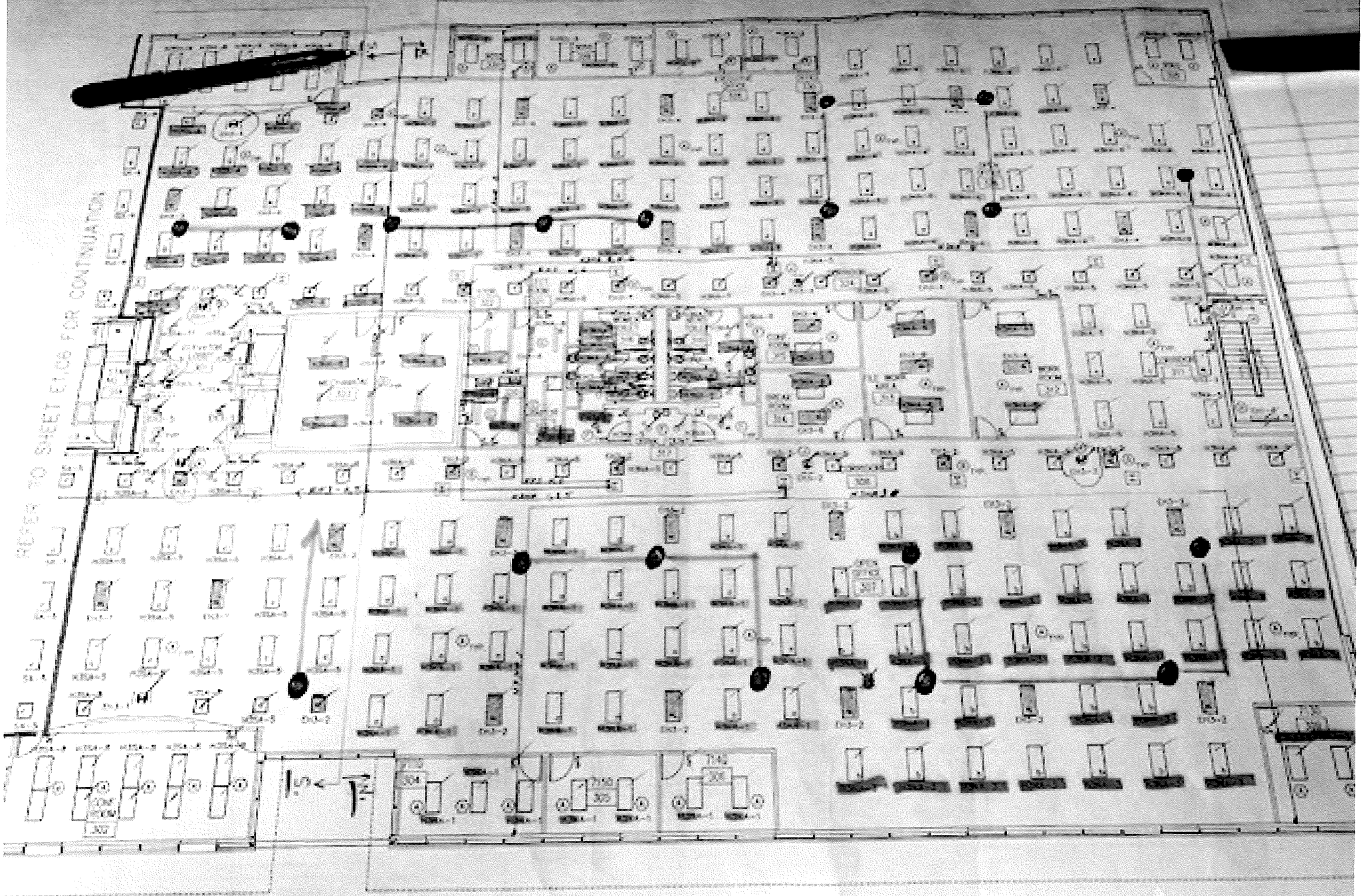

LIGHTING PLAN - THIRD FLOOR NORTH



JLRD, Inc.  
Jun 19, 2020  
Received  
120021 - BE

RFI #1

Robling Architecture Construction  
101 Walker Avenue  
Greenacres, Florida 33463  
Phone: (561) 649-6705  
Fax: 561-649-6748

Project: 20149 - PBSO Temporary Office at SFWMD B2 Building  
3301 Gun Club Road  
West Palm Beach, Florida

### Lighting Controls

<b>TO:</b>	Joe Colome (Colome & Associates, Inc.)	<b>FROM:</b>	Brian Allen (Robling Architecture Construction)
<b>DATE INITIATED:</b>	06/18/2020		101 Walker Avenue Greenacres, Florida 33463
<b>LOCATION:</b>		<b>STATUS:</b>	Open
<b>PROJECT STAGE:</b>	Course of Construction	<b>DUE DATE:</b>	06/23/2020
<b>SUB JOB:</b>		<b>COST CODE:</b>	
<b>COST IMPACT:</b>		<b>SCHEDULE IMPACT:</b>	
<b>DRAWING NUMBER:</b>	E2	<b>SPEC SECTION:</b>	
<b>LINKED DRAWINGS:</b>		<b>REFERENCE:</b>	

RECEIVED FROM:

COPIES TO:

**Question from Brian Allen (Robling Architecture Construction) at 03:23 PM on 06/18/2020**

Revised drawing E2 (REV1 5/12/2020) shows ceiling mounted occupancy sensors throughout the open-plan area, but there is no related keyed note. Keyed note #6 only occurs at the wall-mounted occupant sensors in the private offices. Is it the intent to provide new ceiling mounted sensors as part of this project? If so, please provide a specification.

Awaiting an Official Response

**All Replies:** JLRD Response: Provide ceiling mounted sensor's as shown on drawing. Refer to attached Motion Sensor detail for information.  
K. McPhillips 6/24/2020

JLRD Revised Response: Provide ceiling mounted sensor's as shown on drawing. Sensors shall turn on fixtures in the space. Should the sensor turn on the circuit which serves fixtures located in other areas, that is acceptable considering the occupancy schedule and time of use for all open area spaces is the same. The central contactor / controller may remain. A change order should not be warranted based on this direction.  
C. Gableman 8/6/2020

RAC note: Sensors were not shown on the GMP bid documents. There will be added cost for this work.

BY

DATE

COPIES TO

## Change Order

Malone Electrical Solutions, LLC.  
1540 Donna Road  
West Palm Beach, Florida 33409  
Phone (561) 242-0680  
Fax (561) 242-0882

Proposal Submitted To: Robling Architecture Construction Inc.  
Attn: Brian Allen  
Street Address: 101 Walker Ave  
City, State, Zip Code: Green Acres, FL 33463  
Phone Number: 561-649-6705  
Date of Proposal: August 31, 2020  
Job Name: SFWMD Building B2, 3<sup>rd</sup> Floor PBSO

**Proposed bid price to provide additional electrical as per Revision 2 sheets: # E-2  
Dated: 5/29/20, from Colome & Associates Inc.. Qualification to include the  
following:**

### Sheet E-2:

- Furnish and install (18) ceiling mounted occupancy sensors
- Furnish and install (06) occupancy sensor power packs
- Furnish and install all necessary conduit and Cat6 wiring to interlock occupancy sensors
- Furnish and install all conduit and high voltage wiring to intercept circuits H3NA-1, H3NA-2, H3NA-3, H3NA-4, H3SA-5 & H3SA-6 to connect to occupancy power packs

**Occupancy Sensors** \$ 14,865.00

### OPTIONS (NOT INCLUDED IN BASE BID)

**PERMIT ADDER (IF REQUIRED)** \$ 401.00

**FOURTEEN THOUSAND – EIGHT HUNDRED SIXTY FIVE DOLLARS & XX/100  
\$14,865.00 (Permit fee not included)**

Ray Murdock  
Malone Electrical Solutions, LLC

**ACCEPTANCE of PROPOSAL** The above prices, Specifications, and Conditions are satisfactory and are hereby accepted. You are authorized to do the work as specified. Payment will be made on a monthly basis as billed.

Date of Acceptance: \_\_\_\_\_

Signature \_\_\_\_\_

Print Name \_\_\_\_\_

Note: This proposal may be withdrawn by us  
If not accepted within 30 days

Term: Net 30 DAYS payment is due upon presentation of invoice. Past due accounts will be charged a 1.5% monthly finance charge. If action or suit is brought by Malone Electric, Inc. to collect any amount over due or owing under this bill, Customer agrees to pay all costs of collection including reasonable attorney's fees.



# OEBO SCHEDULE 1

CCP-05

## LIST OF PROPOSED CONTRACTOR/CONSULTANT AND SUBCONTRACTOR/SUBCONSULTANT PARTICIPATION

**SOLICITATION/PROJECT/BID NAME:** SFWMD B2 Bldg. 3rd Floor Renovation for PBSO  
**NAME OF PRIME RESPONDENT/BIDDER:** Robling Architecture Construction, Inc.  
**CONTACT PERSON:** Brian Allen  
**SOLICITATION OPENING/SUBMITTAL DATE:** \_\_\_\_\_

**SOLICITATION/PROJECT/BID No.:** 20149  
**ADDRESS:** 101 Walker Avenue, Greenacres, FL 33463  
**PHONE NO.:** 561-649-6705 **E-MAIL:** ballen@robling.com  
**DEPARTMENT:** Capital Improvements Division

**PLEASE LIST THE DOLLAR AMOUNT OR PERCENTAGE OF WORK TO BE COMPLETED BY THE PRIME CONTRACTOR/CONSULTANT ON THIS PROJECT. PLEASE ALSO LIST THE DOLLAR AMOUNT OR PERCENTAGE OF WORK TO BE COMPLETED BY ALL SUBCONTRACTORS/SUBCONSULTANTS ON THE PROJECT.**

Name, Address and Phone Number	(Check all Applicable Categories)			DOLLAR AMOUNT OR PERCENTAGE OF WORK				
	Non-SBE	M/WBE	SBE	Black	Hispanic	Women	Caucasian	Other
		Minority/Women Business	Small Business					(Please Specify)
1. Robling Architecture Construction, Inc. 101 Walker Avenue, Greenacres, FL 33463 T: 561-649-6705 VC0000103416	<input type="checkbox"/>	<input type="checkbox"/>	<input checked="" type="checkbox"/>	_____	_____	_____	\$743.25	_____
2. Malone Electrical Solutions. LLC 1540 Donna Road, West Palm Beach 33409 561-242-0680 VC0000131964	<input type="checkbox"/>	<input type="checkbox"/>	<input checked="" type="checkbox"/>	_____	_____	_____	\$14,865.00	_____
3.	<input type="checkbox"/>	<input type="checkbox"/>	<input type="checkbox"/>	_____	_____	_____	_____	_____
4.	<input type="checkbox"/>	<input type="checkbox"/>	<input type="checkbox"/>	_____	_____	_____	_____	_____
5.	<input type="checkbox"/>	<input type="checkbox"/>	<input type="checkbox"/>	_____	_____	_____	_____	_____

(Please use additional sheets if necessary)

	<b>Total</b>	_____	_____	_____	_____	\$15,608.25	_____
<b>Total Bid Price \$</b> <u>\$15,608.25</u>	<b>Total SBE - M/WBE Participation</b>	<u>\$15608.25 / 100%</u>					

I hereby certify that the above information is accurate to the best of my knowledge: \_\_\_\_\_  
Signature Vice President Title

- Note:**
1. The amount listed on this form for a Subcontractor/subconsultant must be supported by price or percentage listed on the properly executed Schedule 2 or attached signed proposal.
  2. Firms may be certified by Palm Beach County as an SBE and/or an M/WBE. If firms are certified as both an SBE and/or M/WBE, please indicate the dollar amount under the appropriate category.
  3. Modification of this form is not permitted and will be rejected upon submittal.

OEBO LETTER OF INTENT – SCHEDULE 2

CCP-05

A completed Schedule 2 is a binding document between the Prime Contractor/consultant and a Subcontractor/subconsultant (for any tier) and should be treated as such. The Schedule 2 shall contain bolded language indicating that by signing the Schedule 2, both parties recognize this Schedule as a binding document. All subcontractors/subconsultants, including any tiered subcontractors/subconsultants, must properly execute this document. Each properly executed Schedule 2 must be submitted with the bid/proposal.

SOLICITATION/PROJECT NUMBER: 20149

SOLICITATION/PROJECT NAME: SFWMD B2 Bldg. 3rd Floor Renovation for PBSO

Name of Prime: Robling Architecture Construction, Inc.

(Check box(s) that apply)

SBE  WBE  MBE  M/WBE  Non-S/M/WBE Date of Palm Beach County Certification (if applicable): Exp. 3/18/2023

The undersigned affirms they are the following (select one from each column):

Column 1

Column 2

Male  Female  African-American/Black  Asian American  Caucasian American  
 Hispanic American  Native American

**S/M/WBE PARTICIPATION** – S/M/WBE Primes must document all work to be performed by their own work force on this form. Failure to submit a properly executed Schedule 2 for any S/M/WBE participation may result in that participation not being counted. Specify in detail, the scope of work to be performed or items supplied with the dollar amount and/or percentage for each work item. S/M/WBE credit will only be given for the areas in which the S/M/WBE is certified. A detailed proposal may be attached to a properly executed Schedule 2.

Line Item	Item Description	Unit Price	Qty./Units	Contingencies/ Allowances	Total Price/Percentage
	Electrical				\$14,865.00

The undersigned Subcontractor/subconsultant is prepared to self-perform the above-described work in conjunction with the aforementioned project at the following total price or percentage: \$14,865.00

If the undersigned intends to subcontract any portion of this work to another Subcontractor/subconsultant, please list the business name and the amount below accompanied by a separate properly executed Schedule 2.

n/a Price or Percentage: \_\_\_\_\_

Name of 2<sup>nd</sup>/3<sup>rd</sup> tier Subcontractor/subconsultant

Robling Architecture Construction, Inc.

Print name of Prime

By: [Signature]  
Authorized Signature

Damon A Robling

Print name

President

Title

Date: 9/4/2020

Malone Electrical Solutions

Print name of Subcontractor/subconsultant

By: [Signature]  
Authorized Signature

Raymond B. Murdoch

Print name

President

Title

Date: 9/4/2020

**OEOB LETTER OF INTENT – SCHEDULE 2**

CCP-05

A completed Schedule 2 is a binding document between the Prime Contractor/consultant and a Subcontractor/subconsultant (for any tier) and should be treated as such. The Schedule 2 shall contain bolded language indicating that by signing the Schedule 2, both parties recognize this Schedule as a binding document. All subcontractors/subconsultants, including any tiered subcontractors/subconsultants, must properly execute this document. Each properly executed Schedule 2 must be submitted with the bid/proposal.

SOLICITATION/PROJECT NUMBER: 20149

SOLICITATION/PROJECT NAME: SFWMD B2 Bldg. 3rd Floor Renovation for PBSO

Name of Prime: Robling Architecture Construction, Inc.

**(Check box(s) that apply)**

SBE   WBE   MBE   M/WBE   Non-S/M/WBE   Date of Palm Beach County Certification (if applicable): Exp. 6/26/2021

The undersigned affirms they are the following (select one from each column):

**Column 1**

**Column 2**

Male   Female                      African-American/Black   Asian American   Caucasian American  
Hispanic American                      Native American

**S/M/WBE PARTICIPATION** – S/M/WBE Primes must document all work to be performed by their own work force on this form. Failure to submit a properly executed Schedule 2 for any **S/M/WBE** participation may result in that participation not being counted. Specify in detail, the scope of work to be performed or items supplied with the dollar amount and/or percentage for each work item. S/M/WBE credit will only be given for the areas in which the S/M/WBE is certified. A detailed proposal may be attached to a properly executed Schedule 2.

Line Item	Item Description	Unit Price	Qty./Units	Contingencies/ Allowances	Total Price/Percentage
	Construction Management				\$743.25

The undersigned Subcontractor/subconsultant is prepared to self-perform the above-described work in conjunction with the aforementioned project at the following total price or percentage: \$743.25

**If the undersigned intends to subcontract any portion of this work to another Subcontractor/subconsultant, please list the business name and the amount below accompanied by a separate properly executed Schedule 2.**

\_\_\_\_\_ Price or Percentage: \_\_\_\_\_

**Name of 2<sup>nd</sup>/3<sup>rd</sup> tier Subcontractor/subconsultant**

Robling Architecture Construction, Inc.

Print name of Prime



By: \_\_\_\_\_

Authorized Signature

Damon A Robling

Print name

President

Title

Date: 9/4/2020

Robling Architecture Construction, Inc.

Print name of Subcontractor/subconsultant

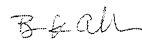

By: \_\_\_\_\_

Authorized Signature

Brian Allen

Print name

Vice President

Title

Date: 9/4/2020

**RIDER INCREASING OR DECREASING PENALTY OF BOND**

To be attached to and form part of Performance and Payment Bond  
(Description of Bond)

Bond No. 2281149 issued on behalf of Robling Architecture Construction, Inc.

as Principal in favor of Palm Beach County Board of County Commissioners

Obligee.

North American Specialty Insurance Co., (hereinafter called the Company) hereby increases  
the penalty from Two Hundred Nineteen Thousand, Eight Hundred Thirty Seven and 00/100 DOLLARS ( \$219,837.00 ),  
to Three Hundred Fifty One Thousand, Eight Hundred Forty Seven and 23/100 DOLLARS ( \$351,847.23 ),  
subject to the covenants and conditions of said bond, except as herein stated.

This rider becomes effective on the 11th day of September, 2020, at  
twelve and one minute o'clock AM standard time.

Signed and dated this 24th day of September, 2020.

Robling Architecture Construction, Inc.  
Principal

By [Signature]

ACCEPTED

Palm Beach County Board of County Commissioners  
Obligee

By \_\_\_\_\_

By \_\_\_\_\_

North American Specialty Insurance Co.

By Brett A. Ragland  
Brett A. Ragland, Attorney-In-Fact



SWISS RE CORPORATE SOLUTIONS

NORTH AMERICAN SPECIALTY INSURANCE COMPANY
WASHINGTON INTERNATIONAL INSURANCE COMPANY
WESTPORT INSURANCE CORPORATION

GENERAL POWER OF ATTORNEY

KNOW ALL MEN BY THESE PRESENTS, THAT North American Specialty Insurance Company, a corporation duly organized and existing under laws of the State of New Hampshire, and having its principal office in the City of Overland Park, Kansas and Washington International Insurance Company a corporation organized and existing under the laws of the State of New Hampshire and having its principal office in the City of Overland Park, Kansas, and Westport Insurance Corporation, organized under the laws of the State of Missouri, and having its principal office in the City of Overland Park, Kansas each does hereby make, constitute and appoint:

JOSEPH D. JOHNSON, JR., JOSEPH D. JOHNSON III, BRETT A. RAGLAND, and FRANCIS T. O'REARDON

JOINTLY OR SEVERALLY

Its true and lawful Attorney(s)-in-Fact, to make, execute, seal and deliver, for and on its behalf and as its act and deed, bonds or other writings obligatory in the nature of a bond on behalf of each of said Companies, as surety, on contracts of suretyship as are or may be required or permitted by law, regulation, contract or otherwise, provided that no bond or undertaking or contract or suretyship executed under this authority shall exceed the amount of: ONE HUNDRED TWENTY FIVE MILLION (\$125,000,000.00) DOLLARS

This Power of Attorney is granted and is signed by facsimile under and by the authority of the following Resolutions adopted by the Boards of Directors of North American Specialty Insurance Company and Washington International Insurance Company at meetings duly called and held on March 24, 2000 and Westport Insurance Corporation by written consent of its Executive Committee dated July 18, 2011.

RESOLVED, that any two of the President, any Senior Vice President, any Vice President, any Assistant Vice President, the Secretary or any Assistant Secretary be, and each or any of them hereby is authorized to execute a Power of Attorney qualifying the attorney named in the given Power of Attorney to execute on behalf of the Company bonds, undertakings and all contracts of surety, and that each or any of them hereby is authorized to attest to the execution of any such Power of Attorney and to attach therein the seal of the Company; and it is

FURTHER RESOLVED, that the signature of such officers and the seal of the Company may be affixed to any such Power of Attorney or to any certificate relating thereto by facsimile, and any such Power of Attorney or certificate bearing such facsimile signatures or facsimile seal shall be binding upon the Company when so affixed and in the future with regard to any bond, undertaking or contract of surety to which it is attached.



By [Signature] Steven P. Anderson, Senior Vice President of Washington International Insurance Company & Senior Vice President of North American Specialty Insurance Company & Senior Vice President of Westport Insurance Corporation

By [Signature] Mike A. Ito, Senior Vice President of Washington International Insurance Company & Senior Vice President of North American Specialty Insurance Company & Senior Vice President of Westport Insurance Corporation



IN WITNESS WHEREOF, North American Specialty Insurance Company, Washington International Insurance Company and Westport Insurance Corporation have caused their official seals to be hereunto affixed, and these presents to be signed by their authorized officers this 22 day of JANUARY, 20 18.

North American Specialty Insurance Company
Washington International Insurance Company
Westport Insurance Corporation

State of Illinois
County of Cook ss:

On this 22 day of JANUARY, 20 18, before me, a Notary Public personally appeared Steven P. Anderson, Senior Vice President of

Washington International Insurance Company and Senior Vice President of North American Specialty Insurance Company and Senior Vice President of Westport Insurance Corporation and Michael A. Ito Senior Vice President of Washington International Insurance Company and Senior Vice President of North American Specialty Insurance Company and Senior Vice President of Westport Insurance Corporation, personally known to me, who being by me duly sworn, acknowledged that they signed the above Power of Attorney as officers of and acknowledged said instrument to be the voluntary act and deed of their respective companies.



[Signature] M. Kenny, Notary Public

I, Jeffrey Goldberg, the duly elected Vice President and Assistant Secretary of North American Specialty Insurance Company, Washington International Insurance Company and Westport Insurance Corporation do hereby certify that the above and foregoing is a true and correct copy of a Power of Attorney given by said North American Specialty Insurance Company, Washington International Insurance Company and Westport Insurance Corporation which is still in full force and effect.

IN WITNESS WHEREOF, I have set my hand and affixed the seals of the Companies this 24th day of September, 20 20.

[Signature]

Jeffrey Goldberg, Vice President & Assistant Secretary of Washington International Insurance Company & North American Specialty Insurance Company & Vice President & Assistant Secretary of Westport Insurance Corporation