

**PALM BEACH COUNTY  
BOARD OF COUNTY COMMISSIONERS**

**AGENDA ITEM SUMMARY**

Meeting Date: April 4, 2023

Consent       Regular  
 Workshop       Public Hearing

Submitted By: Department of Airports

**I. EXECUTIVE BRIEF**

**Motion and Title:** Staff recommends motion to receive and file:

- (A) Registration for Distribution of Literature or Picketing at the Palm Beach International Airport (PBI) issued to NetJets Association of Shared Aircraft Pilots (NJASAP) on February 7, 2023 (Prior Registration), authorizing picketing by members of NJASAP at PBI on February 17, 2023, at no cost.
- (B) Registration for Distribution of Literature or Picketing at PBI issued to NJASAP on February 16, 2023 (Registration), authorizing picketing by members of NJASAP at PBI on February 17, 2023, at no cost and terminating the Prior Registration.

**Summary:** The Registration authorized NJASAP members to picket at PBI, in locations identified in the Registration, in accordance with the Airport Rules and Regulations (R-98-220 as amended) on February 17, 2023. The Registration terminated the Prior Registration and modified the areas on PBI where NJASAP members were authorized to conduct their activities. Delegation of authority for the execution of the standard form Registration was approved by the Board of October 3, 1995 (R-95-1410). **Countywide (AH)**

**Background and Justification:** The Registration details the terms and conditions by which NJASAP members were authorized to conduct its requested picketing activities and is not an endorsement by the County, or by any of its departments, officers or employees of the activities.

**Attachments:**

- 1. Prior Registration
- 2. Registration

Recommended By:

 Paula Burke      3-7-23  
Department Director      Date

Approved By:

 R. Baker      3/15/23  
County Administrator      Date

**II. FISCAL IMPACT ANALYSIS**

**A. Five Year Summary of Fiscal Impact:**

Fiscal Years	<u>2023</u>	<u>2024</u>	<u>2025</u>	<u>2026</u>	<u>2027</u>
Capital Expenditures	_____	_____	_____	_____	_____
Operating Costs	_____	_____	_____	_____	_____
Operating Revenues	_____	_____	_____	_____	_____
Program Income (County)	_____	_____	_____	_____	_____
In-Kind Match (County)	_____	_____	_____	_____	_____
<b>NET FISCAL IMPACT</b>	<u><u>\$-0-</u></u>	<u><u>\$-0-</u></u>	<u><u>\$-0-</u></u>	<u><u>\$-0-</u></u>	<u><u>\$-0-</u></u>
<b># ADDITIONAL FTE POSITIONS (Cumulative)</b>	_____	_____	_____	_____	_____

Is Item Included in Current Budget? Yes \_\_\_\_\_ No X  
 Does this item include the use of federal funds? Yes \_\_\_ No X

Budget Account No: Fund \_\_\_ Department \_\_\_ Unit \_\_\_ RSource \_\_\_  
 Reporting Category \_\_\_\_\_

**B. Recommended Sources of Funds/Summary of Fiscal Impact:**

No fiscal impact.

C. Departmental Fiscal Review: William Duncan  
 (W) 3-7-23

**III. REVIEW COMMENTS**

**A. OFMB Fiscal and/or Contract Development and Control Comments:**

Luz Mata 3/9/2023  
 OFMB 2/23/23  
 ESW 3-9-2023

Ar. J. Favelle 3/10/23  
 Contract Dev. and Control  
 ml 3/10/23

**B. Legal Sufficiency:**

Anne Delmont 3/13/23  
 Assistant County Attorney

**C. Other Department Review:**

\_\_\_\_\_  
 Department Director

REVISED 11/17

(THIS SUMMARY IS NOT TO BE USED AS A BASIS FOR PAYMENT)

**Section 2-1. DISTRIBUTION OF LITERATURE OR PICKETING –  
Registration Required, Procedures.**

A. No person, group of persons, association, organization or business entity (referred to herein as “applicant” or “registrant”) shall distribute literature or picket or display signs for any purpose whether charitable, nonprofit, commercial or otherwise, at the Airport without obtaining an approved registration form issued by the Director of the Department of Airports (hereinafter sometimes referred to as “Director” and may also include any designee of the Director), in accordance with the guidelines set forth herein, or without a license, permit, lease, or contract for a commercial enterprise to be conducted at the Airport. A “commercial enterprise” means any person, group of persons, association, organization or business entity engaging in any profit-making activity, and does not currently qualify for exemption from taxation under Section 501(c) of the Internal Revenue Code of 1954, as amended.

B. Authorization to distribute literature or to picket, as provided for in Section 2-1.A. of these Rules and Regulations, shall be issued using the Registration for Distribution of Literature or Picketing form (the “Registration”), included herein as Section 2-6. of these Rules and Regulations. All applicants shall provide the following required information:

1. The full name, mailing address and telephone number of the applicant;
2. The full name, address, and telephone number of each person who will participate in the authorized activities and of the authorized person(s) who shall have direct supervision of and formal responsibility for the proposed activities. In the alternative, the applicant may identify on the Registration one or more individuals who will act as coordinators or group leaders and, at the beginning of each day’s activities, provide to the Director the names and other information required by this subsection regarding the individuals who will be participating in the applicant’s activities on that day;
3. A description of the nature and purpose of the proposed activity, the type of communication to be involved and, if applicable, submit a copy of any and all literature, hand-outs or other materials or items requesting to be distributed as part of the proposed activities;
4. The requested date(s) and hour(s) on and during which the activities are proposed to be conducted, and the expected duration of the proposed activities;
5. The number of any and all persons to be engaged in such activities in accordance with the limitations set forth in these Rules and Regulations;
6. A statement that the Registration, if granted, will not be used or represented in any way as an endorsement by the County, or by any of its departments, officers or employees thereof;
7. A statement that the applicant has read these Rules and Regulations and agrees to abide thereby;  
and
8. A statement that applicant agrees to indemnify Palm Beach County for any action arising out of the performance of the proposed activities.

C. Upon the applicant providing all of the information required by the Registration and a finding that the information required is complete, the approved Registration shall be signed and issued immediately by the Director. The registrant may, upon issuance, immediately conduct the activities authorized by the Registration, subject to these Rules and Regulations.

D. Registration forms issued pursuant to these Rules and Regulations shall bear the name and address of the registrant, the identification number of the registration, the date issued, and a statement that the Registration does not constitute an endorsement by Palm Beach County or any of its departments, officers or employees.

E. Any Registration form issued under these Rules and Regulations shall be non-transferable and shall be valid only for the periods set forth therein.

F. During the term of any Registration granted herein, if there is any change in fact that would alter the information provided by the registrant, the registrant shall promptly notify the Director of such change, including, if applicable, any change in the literature to be distributed.

G. If a Registration submitted for signing by the Director is denied, a written statement shall be immediately furnished to the applicant setting forth the reason why the Registration has been denied. If such a statement of reasons for denial has not been mailed or delivered within forty-eight (48) hours of the date of receipt by the Director of the completed Registration, an interim Registration shall be deemed issued to the applicant and all activities proposed to be conducted in the Registration may be conducted as subject to the same restrictions and obligations established by these Rules and Regulations for other registrants. A Registration shall be denied for no reason other than any of the following:

1. The applicant has not furnished the information required by these Rules and Regulations;
2. The applicant is a commercial enterprise as set forth in Section 2-1.A. of these Rules and Regulations;
3. A determination of the Director that emergency conditions exist at the Airport which make the applicant's proposed activity incompatible with the operational function of the Airport. For the purposes of these Rules and Regulations, "emergency conditions" shall mean unusually congested conditions due to adverse weather, schedule interruptions, or extremely heavy traffic movements, or for emergency security measures as set forth in Section 496.425(8), Florida Statutes;
4. The Director has determined that one or more statements made in the Registration form are not true or that the activities permitted hereunder will not be under the control or supervision of responsible or reliable persons; or
5. The application is for charitable solicitation and is therefore subject to the Airport's Rules and Regulations for Solicitation of Funds.

H. If the Director notifies the applicant that the Registration is denied, the County Attorney's Office shall within five (5) days of such denial file an appropriate action in a court of competent jurisdiction and venue for a judicial determination as to whether the proposed activity described in the complaint may be prohibited, naming the applicant as a party defendant. Palm Beach County shall exert every reasonable effort to have the issue heard on its merits without delay and as quickly as legally possible. The burden of showing that the proposed activity may be prohibited shall rest with the County. If the issue for judicial determination is not heard and decided on the merits by the court within ten (10) days from the date the complaint is filed then an interim Registration shall be deemed issued to the applicant as set forth in Section 2-1.G. of the these Rules and Regulations.

**Section 2-2. DISTRIBUTION OF LITERATURE OR PICKETING –  
Suspension or Revocation of Registration.**

A. A Registration may be suspended or revoked by the Director for one or more of the following reasons:

1. Violation of any material restriction imposed by these Rules and Regulations or the Registration;
2. Continued, substantial complaints from the public concerning harassment;
3. Any action by the registrant or its agents that adversely affect the health or safety of the public;  
or
4. Fraud or misrepresentation in the Registration.

B. A suspension shall not exceed a period of six (6) months. If a registration has been revoked, a new Registration may not be issued to the person or organization for six (6) months after the revocation. Notice of suspension or revocation shall be in writing and shall be supported by a statement of facts and shall include a list of any witnesses thereto. Such notice shall be personally served upon the registrant or any of its agents, or in the alternative, may be mailed to the registrant by certified mail, return receipt requested. The registrant may request a hearing on a suspension or revocation which shall be held within sixty (60) days of such request.

**Section 2-3. DISTRIBUTION OF LITERATURE OR PICKETING –  
Duration of Registration and Notice to Commence Activities.**

A. An approved Registration form shall be effective for one (1) year from the date of issuance. Once expired, a registrant may apply again on the same basis and subject to the same requirements as any other applicant.

B. During the effective term of the Registration, a registrant may request permission to distribute literature or picket by written request to the official designated on the registration form, or, in the alternative, by reporting in person to such official. Permission will be granted subject only to the limitations set forth in Section 2-4. of these Rules and Regulations.

**Section 2-4. DISTRIBUTION OF LITERATURE OR PICKETING –  
Limitations.**

A. All authorized activities shall be conducted in person by the registrant or the registrant's authorized representatives. No registrant shall place donation boxes, booths, tables, chairs, kiosks or display racks within the Airport terminal building or any other areas of the Airport.

B. In order not to unduly interfere with the orderly flow of the traveling public, all distribution of literature or picketing activities shall be strictly limited to only those non-secured, public use areas of the Airport terminal building as specifically designated on Exhibit "2-6.A" of Section 2-6. of these Rules and Regulations. These designated areas shall be available on a first-come, first-served basis. No more than four (4) persons conducting distribution of literature activities, as authorized pursuant to these Rules and Regulations, shall be present at one-time within those certain areas specified for the conduct of such activities and as designated on Exhibit "2-6.A". All picketing activities, as authorized pursuant to these Rules and Regulations, shall be strictly limited to only those certain areas outside the Airport terminal building specified for the conduct of such activities and as designated on Exhibit

“2-6.A”. No more than ten (10) persons conducting picketing activities pursuant to these Rules and Regulations shall be present at one time within each area.

C. While participating in the activities as authorized by the Registration, registrants shall prominently display on his/her person an identification badge or insignia which shall be visible at all times. Such identification shall be furnished by the Registrant and shall require the prior written approval of the Director. All such badges shall bear the Identification Number of the Registration on file with the Department of Airports.

D. Registrants shall not be permitted to:

1. Obstruct, delay, or in any way interfere with the free movement of others;
2. Seek to coerce or physically disturb others;
3. Hamper or impede the conduct of business;
4. Use any sound or voice amplifying apparatus;
5. Use any drum, bell, tambourine, horn, or other noise making device;
6. In any way indicate to the public that he or she is a representative of the County, the Director or the Airport, or otherwise misrepresent his identity in any way; or
7. Display or carry signs that are larger than three (3) square feet, and such signs shall not be attached or connected to a stick or post of any kind. No sign shall be attached to any portion of the premises of the Airport. All signs and any literature authorized for distribution shall be removed when registrant is not present. No person shall carry more than one (1) sign.

E. The Director may declare an emergency, as set forth in Section 496.425(8), Florida Statutes, as amended, due to unusually congested conditions in, on or about the Airport terminal building which may be caused by adverse weather, schedule interruptions, extremely heavy passenger traffic or any other emergency security situation. In such event, the Director shall cause the registrant or its representative(s) to be so advised either directly or via announcement, and either verbally or in writing. Immediately upon being so advised, the registrant and all representatives of the registrant shall cease conducting any and all activities until such time as the Director provides written notice that the declared emergency no longer exists and that the registrant is specifically authorized to resume its permitted activities.

**Section 2-5. DISTRIBUTION OF LITERATURE OR PICKETING – Scope.**

These Rules and Regulations shall apply to all Palm Beach County owned and operated airports except Section 2-4.B., which shall apply only at Palm Beach International Airport. The Director shall have the authority to prescribe from time-to-time the designated areas and maximum number of persons allowed within such areas for the conduct of authorized distribution of literature and picketing activities at all County owned and operated airports other than Palm Beach International Airport.

PALM BEACH COUNTY  
DEPARTMENT OF AIRPORTS

REGISTRATION  
FOR  
DISTRIBUTION OF LITERATURE OR PICKETING

PALM BEACH INTERNATIONAL AIRPORT

2023-02  
Identification Number

1/24/23  
Date

PLEASE TYPE OR PRINT IN INK THE REQUESTED INFORMATION

1. Full Name, Address and Telephone Number of Applicant (sponsor, promoter or organizer):  
NetJets Association of Shared Aircraft Pilots (NJASAP)

2740 Airport Drive, Suite 330  
Columbus, OH 43219

2. The full name, address, and telephone number of each person who will participate in the authorized activities and of the authorized person(s) who shall have direct supervision of and formal responsibility for the proposed activities. In the alternative, the applicant may identify on the application one or more individuals who will act as coordinators or group leaders and, at the beginning of each day's activities, provide to the Director the names and other information required by this subsection regarding the individuals who will be participating in the applicant's activities on that day:

Paulette Gilbert, 2740 Airport Drive, Suite 330 Columbus, OH 43219 (480) 540-3933  
Matt Williams, 2740 Airport Drive, Suite 330 Columbus, OH 43219 (817) 797-5374

3. Briefly describe the nature of the activity proposed to be conducted, its purpose, and the type of communication to be involved:

Informational Picketing, to bring awareness to NetJets management of their incorrect  
assessment of the pilot labor market. The participants will be utilizing handheld signs. We would  
like to use the grass area along the road as depicted in the attached drawing along Morrison field road.  
We would also like permission to stand in the grass areas south of Signature South and Atlantic  
Aviation. ALL PARKING MUST OCCUR OFF-SITE.

4. (a) The desired date or dates for conducting said activity is:

From 02/17/2023 Through 02/17/2024  
[Attach schedule for seven (7) or more consecutive days]

- (b) The desired times of day during which said activity is to occur:

7am [A.M.] [P.M.] Through 7pm [A.M.] [P.M.]

- (c) The number of people who shall participate in said activity 200

5. If applicable, submit one copy of any and all literature, hand-outs or other materials or items requesting to be distributed as part of the proposed activities. *MATERIALS SHALL BE CONSISTENT WITH EXHIBIT "A" ATTACHED.*

6. Applicant hereby expressly covenants and agrees that if this Registration for Distribution of Literature or Picketing is approved pursuant to this Registration and the accompanying Rules and Regulations for same, applicant shall, as a condition of this Registration, indemnify Palm Beach County pursuant to the following provision which applicant acknowledges and agrees is made a part of and incorporated herein, without the necessity of any further action by the parties hereto:

“REGISTRANT agrees to protect, defend, reimburse, indemnify and hold Palm Beach County (the “COUNTY”), its agents, employees and elected officers and each of them, free and harmless at all times from and against any and all claims, liability, expenses, losses, costs, fines and damages (including attorney fees) and causes of action of every kind and character against or from COUNTY by reason of any damage to property or the environment, or bodily injury (including death) incurred or sustained by any party hereto, or of any party acquiring any interest hereunder, any agent or employee of any party hereto or of any party acquiring an interest hereunder, and any third or other party whomsoever, or any governmental agency, arising out of or incident to or in connection with this Registration, the conditions of the Airport terminal building, REGISTRANT’s acts, omissions or operations hereunder, or the performance, non-performance or purported performance of the REGISTRANT or any breach of the terms of this Registration; provided, however, the REGISTRANT shall not be responsible to COUNTY for damages resulting out of bodily injury or damages to property which REGISTRANT can establish as being attributable to the sole negligence of COUNTY, its respective agents, servants, employees or officers. REGISTRANT further agrees to hold harmless and indemnify COUNTY for any fines, citations, court judgments, insurance claims, restoration costs or other liability resulting from its activities on the Airport. Said indemnification shall be extended to include all deliverers, suppliers or others who may enter onto the Airport at the request of the REGISTRANT. REGISTRANT recognizes the broad nature of this indemnification and hold harmless clause, and voluntarily makes said covenant in recognition of the valuable consideration provided by COUNTY under this Registration. This clause shall survive the termination of this Registration.”

7. Applicant hereby agrees that the Registration, if granted, will not be used or represented in any way as an endorsement by the County, or by any of its departments, officers or employees thereof.

8. Applicant hereby acknowledges that it has received, read and fully understands the Rules and Regulations for Distribution of Literature or Picketing and Supplement to Registration for Distribution of Literature or Picketing attached hereto and made a part hereof and expressly covenants and agrees that it shall strictly adhere to same, as may exist now or as may hereafter be amended, modified or superseded.

**Applicant/Registrant:**

**Paulette Gilbert NJASAP Vice President**  
Print Name of Applicant’s Authorized Representative

  
Signature of Applicant’s Authorized Representative

1/24/23  
Date

**Approval:**

Registration for Distribution of Literature or Picketing is hereby approved by County:

By:  RW  
Director of Airports

1-7-23  
Date

Approved AS TO FORM AND LEGAL SUFFICIENCY:

*1st Anne Helfant*  
COUNTY ATTORNEY



## Supplement to Registration for Distribution of Literature or Picketing

1. **Inspector General.** Palm Beach County has established the Office of the Inspector General in Palm Beach County Code, Section 2-421 – 2-440, as may be amended. The Inspector General’s authority includes but is not limited to the power to review past, present and proposed County contracts, transactions, accounts and records, to require the production of records, and to audit, investigate, monitor, and inspect the activities of the Applicant, its officers, agents, employees and lobbyists in order to ensure compliance with contract requirements and detect corruption and fraud. Failure to cooperate with the Inspector General or interfering with or impeding any investigation shall be in violation of Palm Beach County Code, Section 2-421 – 2-440, and punished pursuant to Section 125.69, Florida Statutes, in the same manner as a second degree misdemeanor.

2. **Scrutinized Companies.** As provided in Florida Statutes (F.S.) 287.135, by entering into this Registration or performing any work in furtherance hereof, the Applicant certifies that it, its affiliates, suppliers, subcontractors and consultants who will perform hereunder, have not been placed on the Scrutinized Companies that boycott Israel List, or is engaged in a boycott of Israel, pursuant to F.S. 215.4725. Pursuant to F.S. 287.135(3)(b), if Applicant is found to have been placed on the Scrutinized Companies that Boycott Israel List or is engaged in a boycott of Israel, this Registration may be terminated at the option of the County. When contract value is greater than \$1 million, as provided in F.S. 287.135, by entering into this Registration or performing any work in furtherance hereof, the Applicant certifies that it, its affiliates, suppliers, subcontractors and consultants who will perform hereunder, have not been placed on the Scrutinized Companies With Activities in Sudan List or Scrutinized Companies With Activities in The Iran Petroleum Energy Sector List created pursuant to F.S. 215.473 or is engaged in business operations in Cuba or Syria. If the County determines, using credible information available to the public, that a false certification has been submitted by Applicant, this Registration may be terminated and a civil penalty equal to the greater of \$2 million or twice the amount of this Registration shall be imposed, pursuant to F.S. 287.135. Said certification must also be submitted at the time of Registration renewal, if applicable.

3. **Signature Authority.** Applicant may be required to complete and submit additional documentation (i.e. corporate resolution, affidavit of limited liability company) confirming the representative has proper authorization to sign the Registration on behalf of the Applicant.

4. **Nondiscrimination.** The County is committed to assuring equal opportunity in the award of contracts and complies with all laws prohibiting discrimination. Pursuant to Palm Beach County Resolution R2017-1770, as may be amended, the Applicant warrants and represents that throughout the term of the Registration, including any renewals thereof, if applicable, all of its employees are treated equally during employment without regard to race, color, religion, disability, sex, age, national origin, ancestry, marital status, familial status, sexual orientation, gender identity or expression, or genetic information. Failure to meet this requirement shall be considered default of the Registration. Applicant shall comply with the Nondiscrimination Requirements set forth below:

### **FEDERAL NONDISCRIMINATION REQUIREMENTS**

#### **A. Title VI Clauses for Compliance with Nondiscrimination Requirements.**

During the performance of this Registration, Applicant, for itself, its assignees, and successors in interest, agrees as follows:

1. **Compliance with Regulations:** Applicant will comply with the Title VI List of Pertinent Nondiscrimination Acts and Authorities (“Nondiscrimination Acts and Authorities” as set forth in paragraph B below), as they may be amended from time to time, which are herein incorporated by reference and made a part of this Registration.
2. **Nondiscrimination:** Applicant, with regard to the work performed by it during this Registration, will not discriminate on the grounds of race, color, or national origin in the selection and retention of subcontractors, including procurements of materials and leases of equipment. Applicant will not participate directly or indirectly in the discrimination prohibited by the Nondiscrimination Acts and Authorities, including employment practices when this Registration covers any activity, project, or program set forth in Appendix B of 49 CFR part 21.
3. **Solicitations for Subcontracts, including Procurements of Materials and Equipment:** In all solicitations, either by competitive bidding or negotiation made by Applicant for work to be performed under a subcontract, including procurements of materials, or leases of equipment, each potential subcontractor or supplier will be notified by Applicant of Applicant’s obligations under this Registration and the Nondiscrimination Acts and Authorities on the grounds of race, color, or national origin.

4. **Information and Reports:** Applicant will provide all information and reports required by the Acts, the Regulations, and directives issued pursuant thereto and will permit access to its books, records, accounts, other sources of information, and its facilities as may be determined by the sponsor or the Federal Aviation Administration to be pertinent to ascertain compliance with such Nondiscrimination Acts and Authorities and instructions. Where any information required of a contractor is in the exclusive possession of another who fails or refuses to furnish the information, Applicant will so certify to the sponsor or the Federal Aviation Administration, as appropriate, and will set forth what efforts it has made to obtain the information.
5. **Sanctions for Noncompliance:** In the event of a contractor's noncompliance with the non-discrimination provisions of this Registration, County will impose such contract sanctions as it or the Federal Aviation Administration may determine to be appropriate, including, but not limited to:
  - a. Withholding payments to Applicant under this Registration until Applicant complies; and/or
  - b. Cancelling, terminating, or suspending a contract, in whole or in part.
6. **Incorporation of Provisions:** Applicant will include the provisions of paragraphs one through six in every subcontract, including procurements of materials and leases of equipment, unless exempt by the Acts, the Regulations, and directives issued pursuant thereto. Applicant will take action with respect to any subcontract or procurement as the sponsor or the Federal Aviation Administration may direct as a means of enforcing such provisions including sanctions for noncompliance. Provided, that if Applicant becomes involved in, or is threatened with litigation by a subcontractor, or supplier because of such direction, Applicant may request the sponsor to enter into any litigation to protect the interests of the sponsor. In addition, Applicant may request the United States to enter into the litigation to protect the interests of the United States.

**B. Title VI List of Pertinent Nondiscrimination Acts and Authorities.**

During the performance of this Registration, Applicant, for itself, its assignees, and successors in interest, agrees to comply with the following non-discrimination statutes and authorities, as may be amended, including but not limited to:

- Title VI of the Civil Rights Act of 1964 (42 USC § 2000d *et seq.*, 78 stat. 252) (prohibits discrimination on the basis of race, color, national origin);
- 49 CFR part 21 (Non-discrimination in Federally-assisted programs of the Department of Transportation—Effectuation of Title VI of the Civil Rights Act of 1964);
- The Uniform Relocation Assistance and Real Property Acquisition Policies Act of 1970, (42 USC § 4601) (prohibits unfair treatment of persons displaced or whose property has been acquired because of Federal or Federal-aid programs and projects);
- Section 504 of the Rehabilitation Act of 1973 (29 USC § 794 *et seq.*), as amended (prohibits discrimination on the basis of disability); and 49 CFR part 27;
- The Age Discrimination Act of 1975, as amended (42 USC § 6101 *et seq.*) (prohibits discrimination on the basis of age);
- Airport and Airway Improvement Act of 1982 (49 USC § 471, Section 47123), as amended (prohibits discrimination based on race, creed, color, national origin, or sex);
- The Civil Rights Restoration Act of 1987 (PL 100-209) (broadened the scope, coverage and applicability of Title VI of the Civil Rights Act of 1964, the Age Discrimination Act of 1975 and Section 504 of the Rehabilitation Act of 1973, by expanding the definition of the terms “programs or activities” to include all of the programs or activities of the Federal-aid recipients, sub-recipients and contractors, whether such programs or activities are Federally funded or not);
- Titles II and III of the Americans with Disabilities Act of 1990, which prohibit discrimination on the basis of disability in the operation of public entities, public and private transportation systems, places of public accommodation, and certain testing entities (42 USC §§ 12131 – 12189) as implemented by U.S. Department of Transportation regulations at 49 CFR parts 37 and 38;
- The Federal Aviation Administration's Nondiscrimination statute (49 USC § 47123) (prohibits discrimination on the basis of race, color, national origin, and sex);
- Executive Order 12898, Federal Actions to Address Environmental Justice in Minority Populations and Low-Income Populations, which ensures nondiscrimination against minority populations by discouraging programs, policies, and activities with disproportionately high and adverse human health or environmental effects on minority and low-income populations;

- Executive Order 13166, Improving Access to Services for Persons with Limited English Proficiency, and resulting agency guidance, national origin discrimination includes discrimination because of limited English proficiency (LEP). To ensure compliance with Title VI, you must take reasonable steps to ensure that LEP persons have meaningful access to your programs (70 Fed. Reg. at 74087 to 74100);
- Title IX of the Education Amendments of 1972, as amended, which prohibits you from discriminating because of sex in education programs or activities (20 USC 1681 et seq).

**C. Title VI Clauses for Construction/Use/Access to Real Property Acquired Under the Activity, Facility or Program.**

1. Applicant for itself and its successors in interest and assigns, as a part of the consideration hereof, does hereby covenant and agree as a covenant running with the land that (1) no person on the ground of race, color, or national origin, will be excluded from participation in, denied the benefits of, or be otherwise subjected to discrimination in the use of said facilities, (2) that in the construction of any improvements on, over, or under such land, and the furnishing of services thereon, no person on the ground of race, color, or national origin, will be excluded from participation in, denied the benefits of, or otherwise be subjected to discrimination, (3) that Applicant will use the Applicant Premises and any License Area in compliance with all other requirements imposed by or pursuant to the Nondiscrimination Acts And Authorities.
2. In the event of breach of any of the above nondiscrimination covenants, County will have the right to terminate this Registration and to enter or re-enter and repossess the Applicant Premises and any License Area and the facilities thereon, and hold the same as if this Registration had never been made or issued.

**D. Title VI Clauses for Transfer of Real Property Acquired or Improved Under the Activity, Facility, or Program.**

Applicant for itself and its successors in interest, and assigns, as a part of the consideration hereof, does hereby covenant and agree as a covenant running with the land that:

1. In the event facilities are constructed, maintained, or otherwise operated on the property described in this Registration for a purpose for which a Federal Aviation Administration activity, facility, or program is extended or for another purpose involving the provision of similar services or benefits, the Applicant will maintain and operate such facilities and services in compliance with all requirements imposed by the Nondiscrimination Acts and Authorities (as may be amended) such that no person on the grounds of race, color, or national origin, will be excluded from participation in, denied the benefits of, or be otherwise subjected to discrimination in the use of said facilities.
2. In the event of breach of any of the above nondiscrimination covenants, County will have the right to terminate this Registration and to enter, re-enter, and repossess said lands and facilities thereon, and hold the same as if this Registration had never been made or issued.

**E. Airport Concession Disadvantaged Business Enterprises (“ACDBE”).**

It is the policy of County that ACDBEs shall have the maximum practicable opportunity to participate in the performance of contracts. In the event this Registration is found to be subject to the requirements of the U.S. Department of Transportation’s regulations, 49 CFR Part 23, Applicant agrees that it will not discriminate against any business owner because of the owner’s race, color, national origin or sex in connection with the award or performance of any concession agreement, management contract, or subcontract, purchase or lease agreement, or other agreement covered by 49 CFR Part 23, and Applicant agrees to include the aforementioned statement in any subsequent concession agreement or contract covered by 49 CFR Part 23, that it enters and cause those businesses to similarly include the statements in further agreements.

**F. General Civil Rights Provision.**

Applicant agrees to comply with pertinent statutes, Executive Orders and such rules as are promulgated to ensure that no person shall, on the grounds of race, creed, color, national origin, sex, age, or disability be excluded from participating in any activity conducted with or benefiting from Federal assistance. If Airline transfers its obligation to another, the transferee is obligated in the same manner as Applicant. This provision obligates Applicant for the period during which the property is owned, used or possessed by Applicant and the Airport remains obligated to the Federal Aviation Administration. This provision is in addition to that required by Title VI of the Civil Rights Act of 1964.

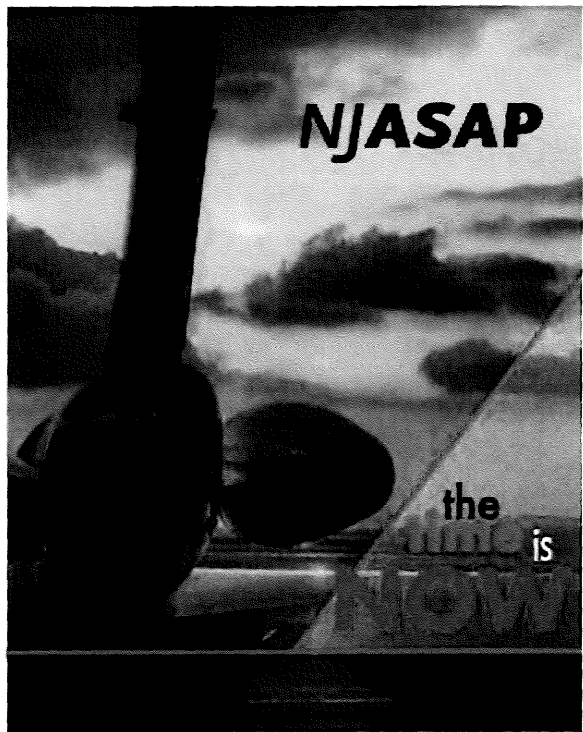

INFORMATIONAL PICKET  
**PARTICIPANT**

EXHIBIT "A"  
EXAMPLE LIBERTY  
PAGE 1

**NJASAP**  
Picket



Participant

PILOT FAMILY MEMBER

EXHIBIT "A"  
EXAMPLE LITERATURES  
PAGE 2

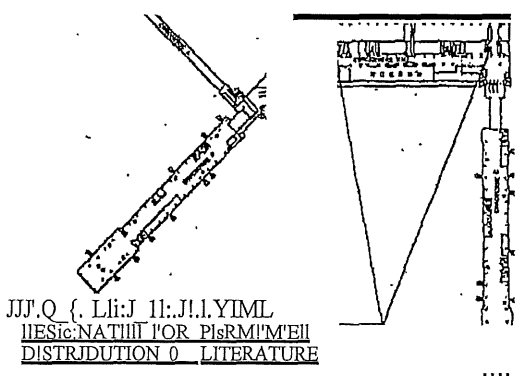
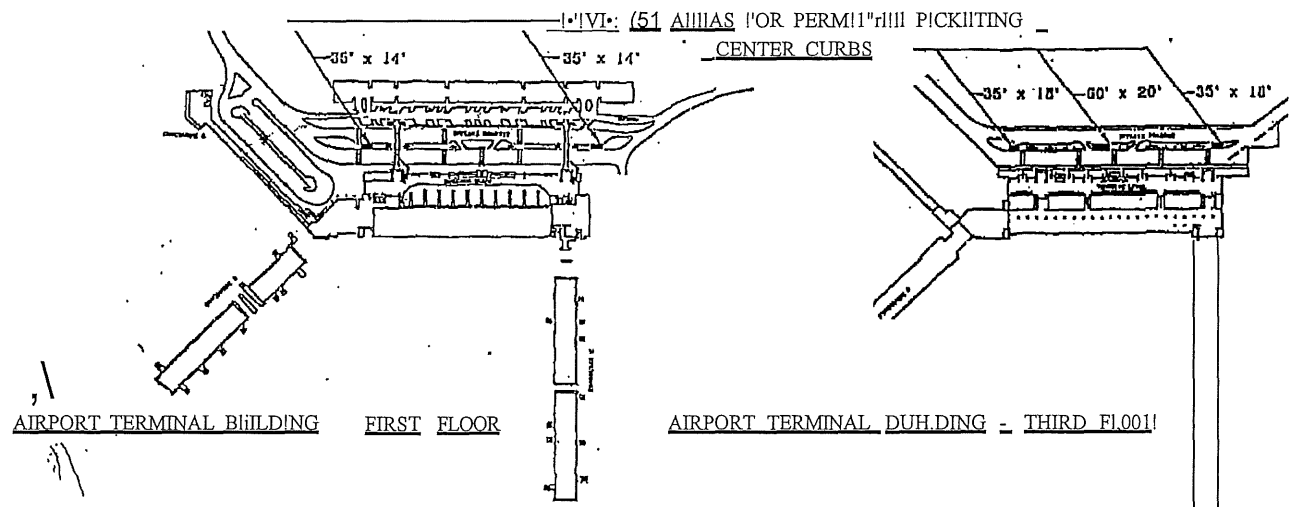

AIRPORT TERMINAL BUILDING - SECOND FLOOR

51 AIRLINES FOR PERMITTED PICKUP/DROPOFF

CENTER CURBS

AIRPORT TERMINAL BUILDING - FIRST FLOOR

AIRPORT TERMINAL BUILDING - THIRD FLOOR

EXHIBIT "2-6. A."  
REGISTRATION FOR DISTRIBUTION  
OF LITERATURE

PALM BEACH COUNTY  
DEPARTMENT OF AIRPORTS  
PALM BEACH INTERNATIONAL AIRPORT  
BUILDING #18  
WEST PALM BEACH, FL 33406-1181



PALM BEACH INTERNATIONAL AIRPORT



EXH. 2-6A

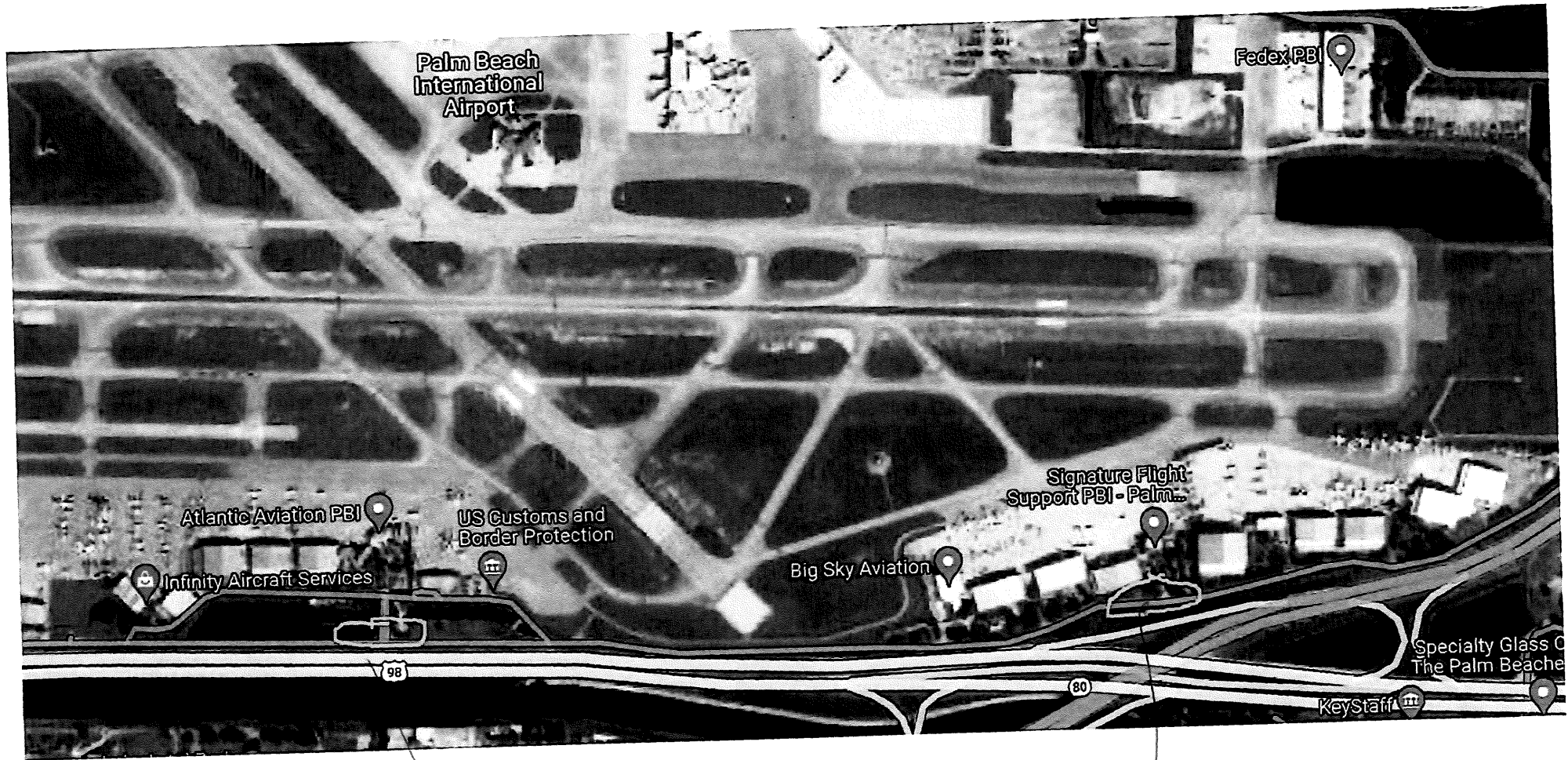

South of  
Access  
Road  
ONLY

South of  
Access Road  
ONLY

EXH 2-64



PALM BEACH COUNTY  
DEPARTMENT OF AIRPORTS

REGISTRATION  
FOR  
DISTRIBUTION OF LITERATURE OR PICKETING

PALM BEACH INTERNATIONAL AIRPORT

2023-03  
Identification Number

2/16/2023  
Date

PLEASE TYPE OR PRINT IN INK THE REQUESTED INFORMATION

1. Full Name, Address and Telephone Number of Applicant (sponsor, promoter or organizer):

NetJets Association of Shared Aircraft Pilots (NJASAP)  
2740 Airport Drive, Suite 330, Columbus, OH 43219 (480) 540-3933

2. The full name, address, and telephone number of each person who will participate in the authorized activities and of the authorized person(s) who shall have direct supervision of and formal responsibility for the proposed activities. In the alternative, the applicant may identify on the application one or more individuals who will act as coordinators or group leaders and, at the beginning of each day's activities, provide to the Director the names and other information required by this subsection regarding the individuals who will be participating in the applicant's activities on that day:

Coordinator: Paulette Gilbert, 2740 Airport Drive, Suite 330, Columbus, OH 43219 (480) 540-3933  
Coordinator: Matt Williams, 2740 Airport Drive, Suite 330, Columbus, OH 43219 (817) 797-5374

3. Briefly describe the nature of the activity proposed to be conducted, its purpose, and the type of communication to be involved:

Informational picketing by members of NJASAP, utilizing hand-held signs consistent with the materials identified in Exhibit "B" attached hereto.

4. (a) The desired date or dates for conducting said activity is: February 17, 2023

(b) The desired times of day during which said activity is to occur:  
9:00 AM Through 5:00 PM

(c) The number of people who shall participate in said activity: The total number of participants may be 200+/-; however, most participants will be off-site and not on the Palm Beach International Airport (PBI). Pursuant to Section 9-2-4 – Limitations – of the Airport Rules and Regulations attached as Exhibit "A", the number of participants at PBI shall be limited to ten (10) persons in each area identified in Exhibit "D" attached hereto (the "Approved Locations").

5. If applicable, submit one copy of any and all literature, hand-outs or other materials or items requesting to be distributed as part of the proposed activities. See example hand-held signs depicted in Exhibit "C" attached hereto.

6. Applicant hereby expressly covenants and agrees that if this Registration for Distribution of Literature or Picketing is approved pursuant to this Registration and the accompanying Rules and Regulations for same (see Exhibit "A"), applicant shall, as a condition of this Registration, indemnify Palm Beach County pursuant to the following provision which applicant acknowledges and agrees is made a part of and incorporated herein, without the necessity of any further action by the parties hereto:

"REGISTRANT agrees to protect, defend, reimburse, indemnify and hold Palm Beach County (the "COUNTY"), its agents, employees and elected officers and each of them, free and harmless at all times from and against any and all claims, liability, expenses, losses, costs, fines and damages (including attorney fees) and causes of action of every kind and character against or from COUNTY by reason of any damage to property or the environment, or bodily injury (including death) incurred or sustained by any party hereto, or of any party acquiring any interest hereunder, any agent or employee of any party hereto or of any party acquiring an interest hereunder, and any third or other party whomsoever, or any governmental agency, arising out of or incident to or in connection with this Registration, the conditions of the Airport terminal building, REGISTRANT's acts, omissions or operations hereunder, or the performance, non-performance or purported performance of the REGISTRANT or any breach of the terms of this Registration; provided, however, the REGISTRANT shall not be responsible to COUNTY for damages resulting out of bodily injury or damages to property which REGISTRANT can establish as being attributable to the sole negligence of COUNTY, its respective agents, servants, employees or officers. REGISTRANT further agrees to hold harmless and indemnify COUNTY for any fines, citations, court judgments, insurance claims, restoration costs or other liability resulting from its activities on the Airport. Said indemnification shall be extended to include all deliverers, suppliers or others who may enter onto the Airport at the request of the REGISTRANT. REGISTRANT recognizes the broad nature of this indemnification and hold harmless clause, and voluntarily makes said covenant in recognition of the valuable consideration provided by COUNTY under this Registration. This clause shall survive the termination of this Registration."

7. Applicant hereby agrees that the Registration, if granted, will not be used or represented in any way as an endorsement by the County, or by any of its departments, officers or employees thereof.

8. Applicant hereby acknowledges that it has received, read and fully understands the Rules and Regulations for Distribution of Literature or Picketing (see Exhibit "A") and Supplement to Registration for Distribution of Literature or Picketing (see Exhibit "B") attached hereto and made a part hereof and expressly covenants and agrees that it shall strictly adhere to same, as may exist now or as may hereafter be amended, modified or superseded.

9. Effective upon the approval of this Registration by both COUNTY and REGISTRANT, that certain Registration No. 2023-2, approved by COUNTY on February 7, 2023, shall be terminated in its entirety.

**Applicant/Registrant:**

<u>Paulette Gilbert</u>	<u></u>	<u>2/16/23</u>
Print Name of Applicant's Authorized Representative	Signature of Applicant's Authorized Representative	Date

**Approval:**

Registration for Distribution of Literature or Picketing is hereby approved by County:

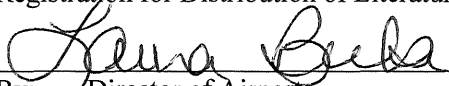
<u></u>	<u>rw</u>	<u>2/16/23</u>
By: Director of Airports		Date

Approved as to Form and Legal Sufficiency:

/s/ Anne Helfant  
County Attorney

Exhibit "A"

Rules and Regulations for Distribution of Literature or Picketing

**ARTICLE IX. SOLICITATION OF FUNDS AND DISTRIBUTION OF LITERATURE, AND  
PICKETING (PALM BEACH INTERNATIONAL AIRPORT)<sup>1</sup>**

**Sec. 9-1. Legislative findings.**

- A. The board of county commissioners of Palm Beach County desires to re-establish regulations for solicitation of funds, distribution of literature, and picketing at Palm Beach County owned and operated airports (the "airport"/"airports"), as now exist or as may hereafter come into being so that such activities may be appropriately exercised without impairing or interfering with the security and operational functions of the airports or interfering with the tenants of the airports, or persons using the airports for their designated purpose.
- B. The board of county commissioners has determined that unrestrained solicitation of funds, distribution of literature, and picketing activities interferes with the movement of arriving and departing airline passengers and is often disruptive to the traveling public.
- C. The board of county commissioners has determined that the rights of freedom of expression must be balanced with the rights of the traveling public to freely access and depart from airplanes and airport facilities.
- D. The board of county commissioners has determined further that passengers, often burdened with luggage and subject to demanding schedules, face an increased risk of duress and opportunity for undetected fraud when confronted with solicitation activities and that the rights of freedom of expression must be balanced with the rights of the traveling public to freely access and depart airplanes and the airports.
- E. The board of county commissioners has determined further that, generally, a problem of congestion in the terminal area, sidewalks, and access roads and areas, and overcrowding of airport facilities exists at the airports from time to time, necessitating the imposition of certain minimum regulations to accommodate the orderly flow of passenger traffic through the airport terminal buildings and terminal areas. Further, the delay and likelihood of congestion created by solicitation, distribution and picketing activities requires the regulation of such activities at the airports.
- F. Consistent with Florida Statutes, § 496.425, as may be amended, it is the intent of the board of county commissioners to accommodate persons and organizations who desire to conduct solicitation activities, while protecting the traveling public, by requiring disclosure of the identity and other information concerning those persons who wish to solicit contributions at the airports.
- G. As the airports do not receive ad valorem tax support, Palm Beach County is dependent upon tenant and passenger revenues to sustain the airports' operations.

(Res. No. R-98-220, §§ 1—8, 2-24-98)

---

<sup>1</sup>Editor's note(s)—The sections of this article have been redesignated by the editor to reflect the article number and to preserve the numbering style of this Appendix B.

---

**Sec. 9-1-1. Solicitation of funds—Application and permit required procedures.**

- A. No person, group of persons, association, organization or business entity (referred to herein as "applicant" or "permittee") shall engage in sponsor, promote or conduct any solicitation of funds, goods or services for any purpose whether charitable, nonprofit, commercial or otherwise, at the airport without a permit issued by the director of the department of airports (hereinafter sometimes referred to as "director" and may also include any designee of the director), in accordance within the guidelines set forth herein, or without a license, permit, lease, or contract for a commercial enterprise to be conducted at the airport. A "commercial enterprise" means any person, group of persons, association, organization or business entity engaging in any profit-making activity, and does not currently qualify for exemption from taxation under Section 501(c) of the Internal Revenue Code of 1954, as amended. For the purpose of these rules and regulations, "solicitation" shall have the same meaning as defined in Section 496.404(21), Florida Statutes, as amended.
- B. A permit application for solicitation of funds, (the "application"), shall be dated, signed and executed by the sponsor, promoter or organizer of the proposed activities and properly notarized and witnessed prior to being delivered to the director. If the applicant is a corporation, the application is to be signed by the authorized corporate officer; if an individual, by that person; if a partnership, by all partners; or if an organization, by the authorized responsible person. All applicants shall provide the following required information:
1. The full name, address and telephone number of the person officially sponsoring, promoting, or conducting the proposed activities, if applicant is not an individual, the names and addresses of the applicant's principal officers, managers and authorized agent for service of process, and a copy of the resolution or other evidence granting authority for such activity are to be provided;
  2. The full name, address, and telephone number of each person who will participate in the authorized activities and of the authorized person(s) who shall have direct supervision of and formal responsibility for the proposed activities;
  3. A description of the nature and purpose of the proposed activity, the type of communication to be involved and, if applicable, submit a copy of any and all literature, hand-outs or other materials or items requesting to be distributed as part of the proposed activities;
  4. The requested date(s) and hour(s) on and during which the activities are proposed to be conducted, and the expected duration of the proposed activities;
  5. The number of any and all persons to be engaged in such activities in accordance with the limitations set forth in these rules and regulations;
  6. A statement that the permit, if granted, will not be used or represented in any way as an endorsement by the county, or by any of its departments, officers or employees thereof;
  7. A statement that the applicant has read these rules and regulations and agrees to abide thereby; and
  8. A statement that applicant agrees to indemnify Palm Beach County for any action arising out of the performance of the proposed activities.
- C. Applicants shall attach to the application a copy of its current consumer certificate of exemption issued by the Florida Department of Revenue pursuant to Florida Statutes, Chapter 496, as may be amended from time to time, or any other documentation applicant may have indicating that applicant has complied with the terms and conditions of Florida Statutes, Chapter 496, as amended.
- D. Within five (5) days of receipt of the fully completed and properly signed application, together with all required supporting documentation, the director shall provide for signing by the applicant (the "permittee") a permit for solicitation of funds (the "permit"), or a written statement setting forth the reason(s) why the

---

application has been denied. If a permit has not been issued and a statement of reasons for denial of permit has not been mailed within five (5) days of the director's receipt of the fully completed and properly signed application, under these rules and regulations an interim permit shall be deemed issued to the applicant and all activities proposed to be conducted in the application for permit may be conducted as subject to the same restrictions and obligations established by these rules and regulations for other permittees. An application shall be denied for no reason other than any of the following:

1. The applicant has not furnished the information required by these rules and regulations, or has failed to properly execute the application, or
  2. The applicant is a commercial enterprise subject to other licensing or leasing requirements at the airport. For the purpose of these rules and regulations a "commercial enterprise" is any person, group of persons, association, organization, or business entity that engages in any profit making activity, and does not qualify at the time of application for exemption from taxation under Section 501(c) of the Internal Revenue Code of 1954, as amended; or
  3. A determination of the director that emergency conditions exist at the airport which make the applicant's proposed activity incompatible with the operational function of the airport. For the purposes of these rules and regulations, "emergency conditions" shall mean unusually congested conditions due to adverse weather, schedule interruptions, or extremely heavy traffic movements, or for emergency security measures as set forth in Florida Statutes, § 496.425(8); or
  4. The director had determined that one or more statements made in the application are not true or that the activities permitted hereunder will not be under the control or supervision of responsible or reliable persons.
- E. If the director notifies the applicant that the application is denied, the county attorney's office shall within five (5) days of such denial file an appropriate action in a court of competent jurisdiction and venue for a judicial determination as to whether the proposed activity described in the complaint may be prohibited, naming the applicant as a party defendant. Palm Beach County shall exert every reasonable effort to have the issue heard on its merits without delay and as quickly as legally possible. The burden of showing that the proposed solicitation may be prohibited shall rest with the county. If the issue for judicial determination is not heard and decided on the merits by the court within ten (10) days from the date the complaint is filed then an interim permit shall be deemed issued to the applicant as set forth in section 9-1-1.D. of these rules and regulations.

(Res. No. R-98-220, §§ 1—8, 2-24-98)

#### **Sec. 9-1-2. Solicitation of funds—Permit suspension or revocation.**

- A. A permit, as issued pursuant to these rules and regulations, may be suspended or revoked by the director for one or more of the following reasons:
1. Violation of any material restriction imposed by these rules and regulations or the permit;
  2. Continued, substantial complaints from the public concerning harassment;
  3. Any action by the permittee or its agents that adversely affect the health or safety of the public; or
  4. Fraud or misrepresentation in the application.
- B. A suspension shall not exceed a period of six (6) months. If a permit has been revoked, a new permit may not be issued to the person or organization for six (6) months after the revocation. Notice of suspension or revocation shall be in writing and shall be supported a statement of facts and shall include a list of any witnesses thereto. Such notice shall be personally served upon permittee or any agent of permittee, or in the

---

alternative, may be mailed to permittee by certified mail, return receipt requested. As set forth in Florida Statutes, § 496.425(10), the permittee may request a hearing on a suspension or revocation which shall be held within sixty (60) days of such request.

(Res. No. R-98-220, §§ 1—8, 2-24-98)

**Sec. 9-1-3. Solicitation of funds—Permit regulations.**

- A. All authorized solicitation activities shall be conducted in person by permittee or the authorized representatives of permittee. No solicitation activities may be conducted by placing donation boxes, booths, tables, chairs, kiosks or display racks, literature or other materials or items within the airport terminal building or any other areas of the airport.
- B. In order to not unduly interfere with the orderly flow of the traveling public, all authorized activities shall be strictly limited to only those nonsecured, public use areas of the airport terminal building as specifically designated on the exhibit to the permit. These designated areas shall be available to permittee on a first-come, first-served basis. No more than four (4) persons conducting activities pursuant to these rules and regulations shall be present at one time within each area.
- C. Permittee shall provide at least three (3) days advance written notice to the Director of its intent to begin the activities as authorized pursuant to the permit. Said written notice shall include the names of the individuals participating in the authorized activities, the specific days requested, not to exceed one (1) calendar week, and the requested hours during each day which the activities will be conducted. The same three-day advance written notice shall be given for each and every subsequent time period authorized under the permit.
- D. While participating in the activities as authorized by the permit, all representatives of permittee shall prominently display on his/her person an identification badge or insignia which shall be visible at all times. Such identification shall be furnished by the permittee and shall require the prior written approval of the director. All such badges or insignias shall bear the signature of the representative and shall include the representative's name, age, height, weight, eye color, hair color, address, and principal occupation, and shall further state the name of the permittee and the organization.
- E. Representatives of permittee shall not be permitted to:
  - 1. Obstruct, delay, or in any way interfere with the free movement of others;
  - 2. Seek to coerce or physically disturb others;
  - 3. Hamper or impede the conduct of business;
  - 4. Use any sound or voice amplifying apparatus;
  - 5. Use any drum, bell, tambourine, horn, or other noise making device;
  - 6. In any way indicate to the public that he or she is a representative of the county, the director or the airport, or otherwise misrepresent his identity in any way; or
  - 7. Display or carry signs that are larger than three (3) square feet, and such signs shall not be attached or connected to a stick or post of any kind. No sign shall be attached to any portion of the premises of the airport. All signs shall be removed when permittee are not present. No person shall carry more than one (1) sign.
- F. The director may declare an emergency, as set forth in Florida Statutes, § 496.425(8), as amended, due to unusually congested conditions in, on or about the airport terminal building which may be caused by adverse weather, schedule interruptions, extremely heavy passenger traffic or any other emergency security situation. In such event, the director shall cause the permittee or its representative(s) to be so advised either directly or via announcement, and either verbally or in writing. Immediately upon being so advised, the

---

Created: 2023-01-11 13:57:18 [EST]

(Supp. No. 113, Update 1)

---

permittee and all representatives of permittee shall cease conducting any and all activities until such time as the director provides written notice that the declared emergency no longer exists and that the permittee is specifically authorized to resume its permitted activities.

(Res. No. R-98-220, §§ 1—8, 2-24-98)

#### **Sec. 9-1-4. Solicitation of funds—Scope.**

These rules and regulations shall apply to all Palm Beach County owned and operated airports except section 9-1-3.B., which shall apply only at Palm Beach International Airport. The director shall have the authority to prescribe from time to time the designated areas and maximum number of persons allowed within such areas for the conduct of authorized solicitation activities at all county owned and operated airports other than Palm Beach International Airport.

(Res. No. R-98-220, §§ 1—8, 2-24-98)

#### **Sec. 9-2-1. Distribution of literature or picketing—registration required; procedures.**

- A. No person, group of persons, association, organization or business entity (referred to herein as "applicant" or "registrant") shall distribute literature or picket or display signs for any purpose whether charitable, nonprofit, commercial or otherwise, at the airport without obtaining an approved registration form issued by the director of the department of airports (hereinafter sometimes referred to as "director" and may also include any designee of the director), in accordance within the guidelines set forth herein, or without a license, permit, lease, or contract for a commercial enterprise to be conducted at the airport. A "commercial enterprise" means any person, group of persons, association, organization or business entity engaging in any profit-making activity, and does not currently qualify for exemption from taxation under Section 501(c) of the Internal Revenue Code of 1954, as amended.
- B. Authorization to distribute literature or to picket, as provided for in section 9-2-1.A. of these rules and regulations, shall be issued using the registration for distribution of literature or picketing form (the "registration"). All applicants shall provide the following required information:
1. The full name, mailing address and telephone number of the applicant;
  2. The full name, address, and telephone number of each person who will participate in the authorized activities and of the authorized person(s) who shall have direct supervision of and formal responsibility for the proposed activities. In the alternative, the applicant may identify on the registration one (1) or more individuals who will act as coordinators or group leaders and, at the beginning of each day's activities, provide to the director the names and other information required by this subsection regarding the individuals who will be participating in the applicant's activities on that day;
  3. A description of the nature and purpose of the proposed activity, the type of communication to be involved and, if applicable, submit a copy of any and all literature, hand-outs or other materials or items requesting to be distributed as part of the proposed activities;
  4. The requested date(s) and hour(s) on and during which the activities are proposed to be conducted, and the expected duration of the proposed activities;
  5. The number of any and all persons to be engaged in such activities in accordance with the limitations set forth in these rules and regulations;
  6. A statement that the registration, if granted, will not be used or represented in any way as an endorsement by the county, or by any of its departments, officers or employees thereof;

---

(Supp. No. 113, Update 1)

Created: 2023-01-11 13:57:18 [EST]



- 
7. A statement that the applicant has read these rules and regulations and agrees to abide thereby; and
  8. A statement that applicant agrees to indemnify Palm Beach County for any action arising out of the performance of the proposed activities.
- C. Upon the applicant providing all of the information required by the registration and a finding that the information required is complete, the approved registration shall be signed and issued immediately by the director. The registrant may, upon issuance, immediately conduct the activities authorized by the registration, subject to these rules and regulations.
  - D. Registration forms issued pursuant to these rules and regulations shall bear the name and address of the registrant the identification number of the registration, the date issued, and a statement that the registration does not constitute an endorsement by Palm Beach County or any of its departments, officers or employees.
  - E. Any registration form issued under these rules and regulations shall be nontransferable and shall be valid only for the periods set forth therein.
  - F. During the term of any registration granted herein, if there is any change in fact that would alter the information provided by the registrant, the registrant shall promptly notify the director of such change, including, if applicable, any change in the literature to be distributed.
  - G. If a registration submitted for signing by the director is denied, a written statement shall be immediately furnished to the applicant setting forth the reason why the registration has been denied. If such a statement of reasons for denial has not been mailed or delivered within forty-eight (48) hours of the date of receipt by the director of the completed registration, an interim registration shall be deemed issued to the applicant and all activities proposed to be conducted in the registration may be conducted as subject to the same restrictions and obligations established by these rules and regulations for other registrants. A registration shall be denied for no reason other than any of the following:
    1. The applicant has not furnished the information required by these rules and regulations;
    2. The applicant is a commercial enterprise as set forth in section 9-2-1.A. of these rules and regulations;
    3. A determination of the director that emergency conditions exist at the airport which make the applicant's proposed activity incompatible with the operational function of the airport. For the purposes of these rules and regulations, "emergency conditions" shall mean unusually congested conditions due to adverse weather, schedule interruptions, or extremely heavy traffic movements, or for emergency security measures as set forth in Florida Statutes, section 496.425(8);
    4. The director has determined that one (1) or more statements made in the registration form are not true or that the activities permitted hereunder will not be under the control or supervision of responsible or reliable persons; or
    5. The application is for charitable solicitation and is subject to the airport's rules and regulations for solicitation of funds.
  - H. If the director notifies the applicant that the registration is denied, the county attorney's office shall within five (5) days of such denial file an appropriate action in a court of competent jurisdiction and venue for a judicial determination as to whether the proposed activity described in the complaint may be prohibited, naming the applicant as a party defendant. Palm Beach County shall exert every reasonable effort to have the issue heard on its merits without delay and as quickly as legally possible. The burden of showing that the proposed activity may be prohibited shall rest with the county. If the issue for judicial determination is not heard and decided on the merits by the court within ten (10) days from the date the complaint is filed then an interim registration shall be deemed issued to the applicant as set forth in section 9-2-1.G. of these rules and regulations.

---

(Res. No. R-98-220, §§ 1—8, 2-24-98)

**Sec. 9-2-2. Distribution of literature or picketing—Suspension or revocation of registration.**

- A. A registration may be suspended or revoked by the director for one (1) or more of the following reasons:
1. Violation of any material restriction imposed by these rules and regulations or the registration;
  2. Continued, substantial complaints from the public concerning harassment;
  3. Any action by the registrant or its agents that adversely affect the health or safety of the public; or
  4. Fraud or misrepresentation in the registration.
- B. A suspension shall not exceed a period of six (6) months. If a registration has been revoked, a new registration may not be issued to the person or organization for six (6) months after the revocation. Notice of suspension or revocation shall be in writing and shall be supported a statement of facts and shall include a list of any witnesses thereto. Such notice shall be personally served upon the registrant or any of its agents, or in the alternative, may be mailed to the registrant by certified mail, return receipt requested. The registrant may request a hearing on a suspension or revocation which shall be held within sixty (60) days of such request.

(Res. No. R-98-220, §§ 1—8, 2-24-98)

**Sec. 9-2-3. Picketing or distribution of literature—Duration of registration and notice to commence activities.**

- A. An approved registration form shall be effective for one (1) year from the date of issuance. Once expired, a registrant may apply again on the same basis and subject to the same requirements as any other applicant.
- B. During the effective term of the registration, a registrant may request permission to distribute literature or picket by written request to the official designated on the registration form, or, in the alternative, by reporting in person to such official. Permission will be granted subject only to the limitations set forth in section 2-4 of these rules and regulations below.

(Res. No. R-98-220, §§ 1—8, 2-24-98)

**Sec. 9-2-4. Distribution of literature or picketing—Limitations.**

- A. All authorized activities shall be conducted in person by the registrant or the registrant's authorized representatives. No registrant shall place donation boxes, tables, chairs, booths, kiosks or display racks within the airport terminal building or any other areas of the airport.
- B. In order to not unduly interfere with the orderly flow of the traveling public, all distribution of literature or picketing activities shall be strictly limited to only those nonsecured, public use areas of the airport terminal building as specifically designated on the exhibit to the registration. These designated areas shall be available on a first-come, first-served basis. No more than four (4) persons conducting distribution of literature activities, as authorized pursuant to these rules and regulations, shall be present at one time within those certain areas specified for the conduct of such activities and as designated on the exhibit to the registration. All picketing activities, as authorized pursuant to these rules and regulations, shall be strictly limited to only those certain areas outside the airport terminal building specified for the conduct of such activities and as designated on the exhibit to the registration. No more than ten (10) persons conducting picketing activities pursuant to these rules and regulations shall be present at one time within each area.

---

(Supp. No. 113, Update 1)

Created: 2023-01-11 13:57:18 [EST]

- 
- C. While participating in the activities as authorized by the registration, registrants shall prominently display on his/her person an identification badge or insignia which shall be visible at all times. Such identification shall be furnished by the registrant and shall require the prior written approval of the director. All such badges shall bear the identification number of the registration on file with the department of airports.
- D. Registrants shall not be permitted to:
1. Obstruct, delay, or in any way interfere with the free movement of others;
  2. Seek to coerce or physically disturb others;
  3. Hamper or impede the conduct of business;
  4. Use any sound or voice amplifying apparatus;
  5. Use any drum, bell, tambourine, horn, or other noise making device;
  6. In any way indicate to the public that he or she is a representative of the county, the director or the airport, or otherwise misrepresent his identity in any way; or
  7. Display or carry signs that are larger than three (3) square feet, and such signs shall not be attached or connected to a stick or post of any kind. No sign shall be attached to any portion of the premises of the airport. All signs and any literature authorized for distribution shall be removed when registrant is not present. No person shall carry more than one (1) sign.
- E. The director may declare an emergency, as set forth in Florida Statutes, § 496.425(8), as amended, due to unusually congested conditions in, on or about the airport terminal building which may be caused by adverse weather, schedule interruptions, extremely heavy passenger traffic or any other emergency security situation. In such event, the director shall cause the registrant or its representative(s) to be so advised either directly or via announcement, and either verbally or in writing. Immediately upon being so advised, the registrant and all representatives of the registrant shall cease conducting any and all activities until such time as the director provides written notice that the declared emergency no longer exists and that the registrant is specifically authorized to resume its permitted activities.

(Res. No. R-98-220, §§ 1—8, 2-24-98)

#### **Sec. 9-2-5. Distribution of literature or picketing—Scope.**

These rules and regulations shall apply to all Palm Beach County owned and operated airports except section 9-2-4.B., which shall apply only at Palm Beach International Airport. The director shall have the authority to prescribe from time to time the designated areas and maximum number of persons allowed within such areas for the conduct of authorized distribution of literature and picketing activities at all county owned and operated airports other than Palm Beach International Airport.

(Res. No. R-98-220, §§ 1—8, 2-24-98)

**Exhibit "B"**  
**Supplement to Registration for Distribution of Literature or Picketing**

1. **Inspector General.** Palm Beach County has established the Office of the Inspector General in Palm Beach County Code, Section 2-421 – 2-440, as may be amended. The Inspector General's authority includes but is not limited to the power to review past, present and proposed County contracts, transactions, accounts and records, to require the production of records, and to audit, investigate, monitor, and inspect the activities of the Applicant, its officers, agents, employees and lobbyists in order to ensure compliance with contract requirements and detect corruption and fraud. Failure to cooperate with the Inspector General or interfering with or impeding any investigation shall be in violation of Palm Beach County Code, Section 2-421 – 2-440, and punished pursuant to Section 125.69, Florida Statutes, in the same manner as a second degree misdemeanor.

2. **Scrutinized Companies.** As provided in Florida Statutes (F.S.) 287.135, by entering into this Registration or performing any work in furtherance hereof, the Applicant certifies that it, its affiliates, suppliers, subcontractors and consultants who will perform hereunder, have not been placed on the Scrutinized Companies that boycott Israel List, or is engaged in a boycott of Israel, pursuant to F.S. 215.4725. Pursuant to F.S. 287.135(3)(b), if Applicant is found to have been placed on the Scrutinized Companies that Boycott Israel List or is engaged in a boycott of Israel, this Registration may be terminated at the option of the County. When contract value is greater than \$1 million, as provided in F.S. 287.135, by entering into this Registration or performing any work in furtherance hereof, the Applicant certifies that it, its affiliates, suppliers, subcontractors and consultants who will perform hereunder, have not been placed on the Scrutinized Companies With Activities in Sudan List or Scrutinized Companies With Activities in The Iran Petroleum Energy Sector List created pursuant to F.S. 215.473 or is engaged in business operations in Cuba or Syria. If the County determines, using credible information available to the public, that a false certification has been submitted by Applicant, this Registration may be terminated and a civil penalty equal to the greater of \$2 million or twice the amount of this Registration shall be imposed, pursuant to F.S. 287.135. Said certification must also be submitted at the time of Registration renewal, if applicable.

3. **Signature Authority.** Applicant may be required to complete and submit additional documentation (i.e. corporate resolution, affidavit of limited liability company) confirming the representative has proper authorization to sign the Registration on behalf of the Applicant.

4. **Nondiscrimination.** The County is committed to assuring equal opportunity in the award of contracts and complies with all laws prohibiting discrimination. Pursuant to Palm Beach County Resolution R2017-1770, as may be amended, the Applicant warrants and represents that throughout the term of the Registration, including any renewals thereof, if applicable, all of its employees are treated equally during employment without regard to race, color, religion, disability, sex, age, national origin, ancestry, marital status, familial status, sexual orientation, gender identity or expression, or genetic information. Failure to meet this requirement shall be considered default of the Registration. Applicant shall comply with the Federal Nondiscrimination Requirements set forth below:

**FEDERAL NONDISCRIMINATION REQUIREMENTS**

**A. Title VI Clauses for Compliance with Nondiscrimination Requirements.**

During the performance of this Registration, Applicant, for itself, its assignees, and successors in interest, agrees as follows:

1. **Compliance with Regulations:** Applicant will comply with the Title VI List of Pertinent Nondiscrimination Acts and Authorities ("Nondiscrimination Acts and Authorities" as set forth in paragraph B below), as they may be amended from time to time, which are herein incorporated by reference and made a part of this Registration.
2. **Nondiscrimination:** Applicant, with regard to the work performed by it during this Registration, will not discriminate on the grounds of race, color, or national origin in the selection and retention of subcontractors, including procurements of materials and leases of equipment. Applicant will not participate directly or indirectly in the discrimination prohibited by the Nondiscrimination Acts and Authorities, including employment practices when this Registration covers any activity, project, or program set forth in Appendix B of 49 CFR part 21.
3. **Solicitations for Subcontracts, including Procurements of Materials and Equipment:** In all solicitations, either by competitive bidding or negotiation made by Applicant for work to be performed under a subcontract, including procurements of materials, or leases of equipment, each potential subcontractor or supplier will be notified by Applicant of Applicant's obligations under this Registration and the Nondiscrimination Acts and Authorities on the grounds of race, color, or national origin.

4. **Information and Reports:** Applicant will provide all information and reports required by the Acts, the Regulations, and directives issued pursuant thereto and will permit access to its books, records, accounts, other sources of information, and its facilities as may be determined by the sponsor or the Federal Aviation Administration to be pertinent to ascertain compliance with such Nondiscrimination Acts and Authorities and instructions. Where any information required of a contractor is in the exclusive possession of another who fails or refuses to furnish the information, Applicant will so certify to the sponsor or the Federal Aviation Administration, as appropriate, and will set forth what efforts it has made to obtain the information.
5. **Sanctions for Noncompliance:** In the event of a contractor's noncompliance with the non-discrimination provisions of this Registration, County will impose such contract sanctions as it or the Federal Aviation Administration may determine to be appropriate, including, but not limited to:
  - a. Withholding payments to Applicant under this Registration until Applicant complies; and/or
  - b. Cancelling, terminating, or suspending a contract, in whole or in part.
6. **Incorporation of Provisions:** Applicant will include the provisions of paragraphs one through six in every subcontract, including procurements of materials and leases of equipment, unless exempt by the Acts, the Regulations, and directives issued pursuant thereto. Applicant will take action with respect to any subcontract or procurement as the sponsor or the Federal Aviation Administration may direct as a means of enforcing such provisions including sanctions for noncompliance. Provided, that if Applicant becomes involved in, or is threatened with litigation by a subcontractor, or supplier because of such direction, Applicant may request the sponsor to enter into any litigation to protect the interests of the sponsor. In addition, Applicant may request the United States to enter into the litigation to protect the interests of the United States.

**B. Title VI List of Pertinent Nondiscrimination Acts and Authorities.**

During the performance of this Registration, Applicant, for itself, its assignees, and successors in interest, agrees to comply with the following non-discrimination statutes and authorities, as may be amended, including but not limited to:

- Title VI of the Civil Rights Act of 1964 (42 USC § 2000d *et seq.*, 78 stat. 252) (prohibits discrimination on the basis of race, color, national origin);
- 49 CFR part 21 (Non-discrimination in Federally-assisted programs of the Department of Transportation—Effectuation of Title VI of the Civil Rights Act of 1964);
- The Uniform Relocation Assistance and Real Property Acquisition Policies Act of 1970, (42 USC § 4601) (prohibits unfair treatment of persons displaced or whose property has been acquired because of Federal or Federal-aid programs and projects);
- Section 504 of the Rehabilitation Act of 1973 (29 USC § 794 *et seq.*), as amended (prohibits discrimination on the basis of disability); and 49 CFR part 27;
- The Age Discrimination Act of 1975, as amended (42 USC § 6101 *et seq.*) (prohibits discrimination on the basis of age);
- Airport and Airway Improvement Act of 1982 (49 USC § 471, Section 47123), as amended (prohibits discrimination based on race, creed, color, national origin, or sex);
- The Civil Rights Restoration Act of 1987 (PL 100-209) (broadened the scope, coverage and applicability of Title VI of the Civil Rights Act of 1964, the Age Discrimination Act of 1975 and Section 504 of the Rehabilitation Act of 1973, by expanding the definition of the terms “programs or activities” to include all of the programs or activities of the Federal-aid recipients, sub-recipients and contractors, whether such programs or activities are Federally funded or not);
- Titles II and III of the Americans with Disabilities Act of 1990, which prohibit discrimination on the basis of disability in the operation of public entities, public and private transportation systems, places of public accommodation, and certain testing entities (42 USC §§ 12131 – 12189) as implemented by U.S. Department of Transportation regulations at 49 CFR parts 37 and 38;
- The Federal Aviation Administration's Nondiscrimination statute (49 USC § 47123) (prohibits discrimination on the basis of race, color, national origin, and sex);
- Executive Order 12898, Federal Actions to Address Environmental Justice in Minority Populations and Low-Income Populations, which ensures nondiscrimination against minority populations by discouraging programs, policies, and activities with disproportionately high and adverse human health or environmental effects on minority and low-income populations;

- Executive Order 13166, Improving Access to Services for Persons with Limited English Proficiency, and resulting agency guidance, national origin discrimination includes discrimination because of limited English proficiency (LEP). To ensure compliance with Title VI, you must take reasonable steps to ensure that LEP persons have meaningful access to your programs (70 Fed. Reg. at 74087 to 74100);
- Title IX of the Education Amendments of 1972, as amended, which prohibits you from discriminating because of sex in education programs or activities (20 USC 1681 et seq).

**C. Title VI Clauses for Construction/Use/Access to Real Property Acquired Under the Activity, Facility or Program.**

1. Applicant for itself and its successors in interest and assigns, as a part of the consideration hereof, does hereby covenant and agree as a covenant running with the land that (1) no person on the ground of race, color, or national origin, will be excluded from participation in, denied the benefits of, or be otherwise subjected to discrimination in the use of said facilities, (2) that in the construction of any improvements on, over, or under such land, and the furnishing of services thereon, no person on the ground of race, color, or national origin, will be excluded from participation in, denied the benefits of, or otherwise be subjected to discrimination, (3) that Applicant will use the Applicant Premises and any License Area in compliance with all other requirements imposed by or pursuant to the Nondiscrimination Acts And Authorities.
2. In the event of breach of any of the above nondiscrimination covenants, County will have the right to terminate this Registration and to enter or re-enter and repossess the Applicant Premises and any License Area and the facilities thereon, and hold the same as if this Registration had never been made or issued.

**D. Title VI Clauses for Transfer of Real Property Acquired or Improved Under the Activity, Facility, or Program.**

Applicant for itself and its successors in interest, and assigns, as a part of the consideration hereof, does hereby covenant and agree as a covenant running with the land that:

1. In the event facilities are constructed, maintained, or otherwise operated on the property described in this Registration for a purpose for which a Federal Aviation Administration activity, facility, or program is extended or for another purpose involving the provision of similar services or benefits, the Applicant will maintain and operate such facilities and services in compliance with all requirements imposed by the Nondiscrimination Acts and Authorities (as may be amended) such that no person on the grounds of race, color, or national origin, will be excluded from participation in, denied the benefits of, or be otherwise subjected to discrimination in the use of said facilities.
2. In the event of breach of any of the above nondiscrimination covenants, County will have the right to terminate this Registration and to enter, re-enter, and repossess said lands and facilities thereon, and hold the same as if this Registration had never been made or issued.

**E. Airport Concession Disadvantaged Business Enterprises (“ACDBE”).**

It is the policy of County that ACDBEs shall have the maximum practicable opportunity to participate in the performance of contracts. In the event this Registration is found to be subject to the requirements of the U.S. Department of Transportation’s regulations, 49 CFR Part 23, Applicant agrees that it will not discriminate against any business owner because of the owner’s race, color, national origin or sex in connection with the award or performance of any concession agreement, management contract, or subcontract, purchase or lease agreement, or other agreement covered by 49 CFR Part 23, and Applicant agrees to include the aforementioned statement in any subsequent concession agreement or contract covered by 49 CFR Part 23, that it enters and cause those businesses to similarly include the statements in further agreements.

**F. General Civil Rights Provision.**

Applicant agrees to comply with pertinent statutes, Executive Orders and such rules as are promulgated to ensure that no person shall, on the grounds of race, creed, color, national origin, sex, age, or disability be excluded from participating in any activity conducted with or benefiting from Federal assistance. If Airline transfers its obligation to another, the transferee is obligated in the same manner as Applicant. This provision obligates Applicant for the period during which the property is owned, used or possessed by Applicant and the Airport remains obligated to the Federal Aviation Administration. This provision is in addition to that required by Title VI of the Civil Rights Act of 1964.

Exhibit "C"  
Example Hand-Held Signs

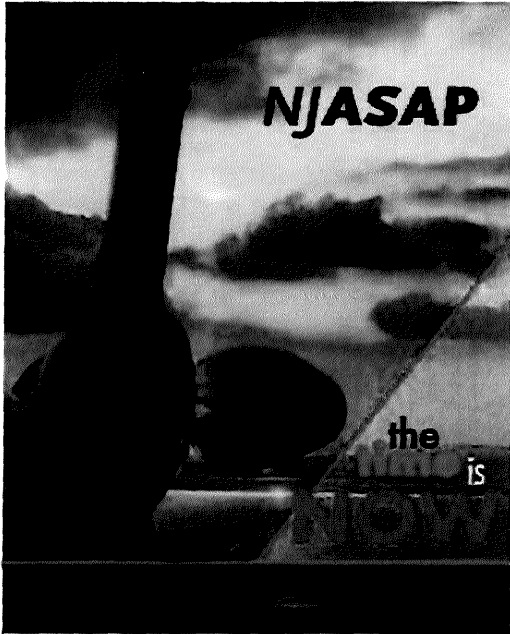

INFORMATIONAL PICKET  
**PARTICIPANT**

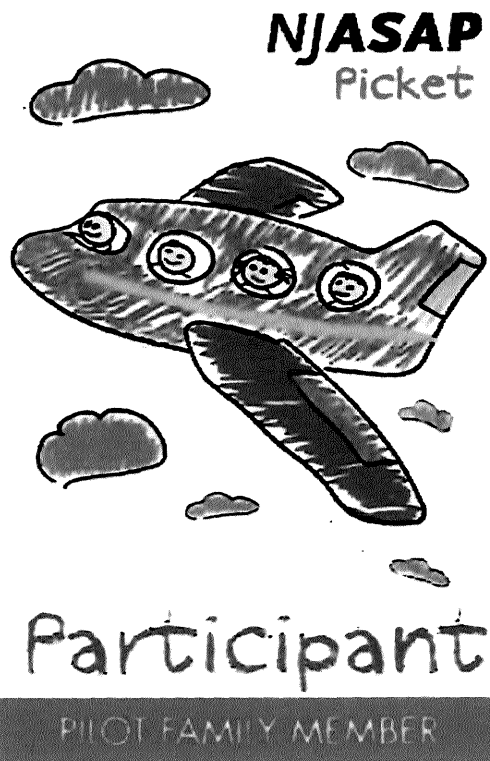

**Exhibit “D”  
The “Approved Locations”**

**There shall be eight (8) separate areas as listed and depicted below. Registrant shall limit the number of participants to no more than ten (10) participants in each area at one time. Participants shall be shuttled to each location; No vehicles shall be permitted, except for a shuttle bus.**

**Areas 1 – 5**

Five (5) areas on the north side of Morrison Field Road, across from the Signature/NetJets facility. Each area is identified by a “box” spray painted on the grass. Each area is set-back ten (10) feet from the road and separated from the canal. Registrant is advised that the adjacent canal area has an unsafe bank and is inhabited by several large alligators and iguanas. A separate area on the north side of the road, west of the entry to NetJets, has been marked for the “bus” to drop-off and pick-up passengers.

Bus traffic should continue west on Morrison Field Road and exit via Green Street west to Military Trail.





**Area 6**

South side of Perimeter Road adjacent to Atlantic Aviation:



**Area 7**

South side of Perimeter Road adjacent to Signature Flight Support:

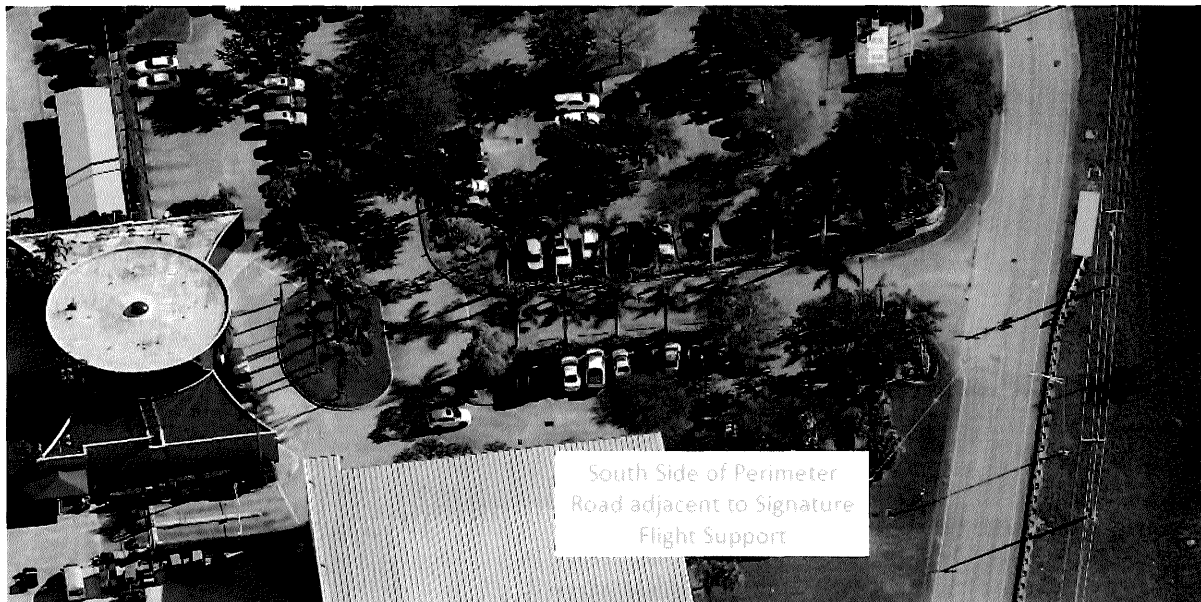

**Area 8**

South side of Perimeter Road adjacent to Jet Aviation:

