

**PALM BEACH COUNTY  
BOARD OF COUNTY COMMISSIONERS  
AGENDA ITEM SUMMARY**

**Meeting Date: April 4, 2023**

**Consent**

**Regular**

**Workshop**

**Public Hearing**

**Department: Facilities Development & Operations**

**I. EXECUTIVE BRIEF**

**Motion and Title: Staff recommends motion to approve:** Change Order No. 1 to the sole source contract (R2021-1070) with Amano McGann, Inc. in the amount of \$47,055 with an increase to the project duration of 225 calendar days for the Judicial Center Parking Garage, and the State Attorney/Public Defender (SAPD) Parking Lot project.

**Summary:** On August 17, 2021, the Board of County Commissioners (Board) approved a sole source contract (R2021-1070) with Amano McGann, Inc. in the amount of \$336,974.60 for a period of 60 days from permit issuance for the installation of the OPUS parking access and revenue control systems at the entry and exit lanes for the Judicial Center Parking Garage, and the SAPD Parking Lot project. Change Order No. 1 to the sole source contract (R2021-1070) authorizes the replacement of the existing gate arms with gate arms with integrated lighting, installation of electrical patch panels and additional low voltage wiring, installation of additional revenue collection equipment and the furnishing of additional OPUS supplies. Change Order No. 1 to the sole source contract (R2021-1070) will also authorize an increase in the project duration of 225 calendar days to accommodate the fiber network replacement. In accordance with the Equal Business Opportunity (EBO) ordinance, sole source procurements are exempt from EBO requirements. Funding for this project is from the Public Building Improvement Fund. **(Capital Improvements Division) District 7 (MWJ)**

**Background and Justification:** In 2019, the County solicited vendor services for parking garage and parking lot improvements to four (4) parking lots including the Governmental Center Parking Garage, the Judicial Center Parking Garage, the SAPD Parking Garage and the 4th Street Parking lot. The parking improvements included the addition of barrier gates, card readers and new server and software upgrades. Due to insufficient funds at the time, the Governmental Center Parking Garage and the 4th Street Parking lot were the only two (2) parking lots completed under the solicitation. The newly installed OPUS parking access and revenue control system included server hardware and software; automatic vehicle identification (AVI) readers; communication controllers; and AVI access control cards. The sole source contract (R2021-1070) with Amano McGann, Inc. for the Judicial Center Parking Garage, and the SAPD Parking Lot project authorized the installation of the OPUS parking access and revenue control systems at the entry and exit lanes for the remaining parking garage and parking lot. Change Order No. 1 to the sole source contract (R2021-1070) authorizes the replacement of the existing gate arms with gate arms with integral lighting, installation of electrical patch panels and additional low voltage wiring, installation of additional revenue collection equipment and the furnishing of additional OPUS supplies necessary to maintain the required compatibility.

**Attachments:**

- 1. Location Maps
- 2. Budget Availability Statement
- 3. Change Order No. 1

**Recommended by:**  3/9/23  
 Department Director Date

**Approved by:**  3/20/23  
 County Administrator Date

**II. FISCAL IMPACT ANALYSIS**

<b>Fiscal Years</b>	<b>2023</b>	<b>2024</b>	<b>2025</b>	<b>2026</b>	<b>2027</b>
<b>Capital Expenditures</b>	\$47,055	_____	_____	_____	_____
<b>Operating Costs</b>	_____	_____	_____	_____	_____
<b>External Revenues</b>	_____	_____	_____	_____	_____
<b>Program Income (County)</b>	_____	_____	_____	_____	_____
<b>In-Kind Match (County)</b>	_____	_____	_____	_____	_____
<b>NET FISCAL IMPACT</b>	\$47,055	<u>-0-</u>	<u>-0-</u>	<u>-0-</u>	<u>-0-</u>
<b># ADDITIONAL FTE POSITIONS (Cumulative)</b>	_____	_____	_____	_____	_____

Is Item Included in Current Budget: Yes   X   No \_\_\_\_\_  
 Does this item include the use of federal funds? Yes \_\_\_\_\_ No   X  

**Budget Account No: Fund 3804 Dept. 411 Unit B675-0025 Object 4907**

CONSTRUCTION	\$47,055.00
STAFF COSTS	\$ 0.00
CONTINGENCY	\$ 0.00
TOTAL	\$47,055.00

**B. Recommended Sources of Funds/Summary of Fiscal Impact:**

Funding for this project is from the Public Building Improvement Fund.

C. Departmental Fiscal Review: *David Eric Muller*  
*HBSM*

**III. REVIEW COMMENTS:**

**A. OFMB Fiscal and/or Contract Development and Control Comments:**

<p><u><i>ASD</i></u> <u>3/13/23</u>          OFMB <u>CA 3110</u> <i>EJW</i>  <i>3-10-23</i></p>	<p><u><i>Dr. J. Jacobson</i></u> <u>3/16/23</u>          Contract Administrator  <i>md 3/10/23</i></p>
---	--

**B. Legal Sufficiency:**

*[Signature]* 3/17/23  
 Assistant County Attorney

**C. Other Department Review:**

\_\_\_\_\_  
 Department Director

# LOCATION MAP

**Project No:** 20157  
**Project Name:** Judicial Center Parking Garage and SAPD Parking Lot

**Location:** 505 Banyan Boulevard, West Palm Beach, Florida 33401 (Judicial Center Garage)

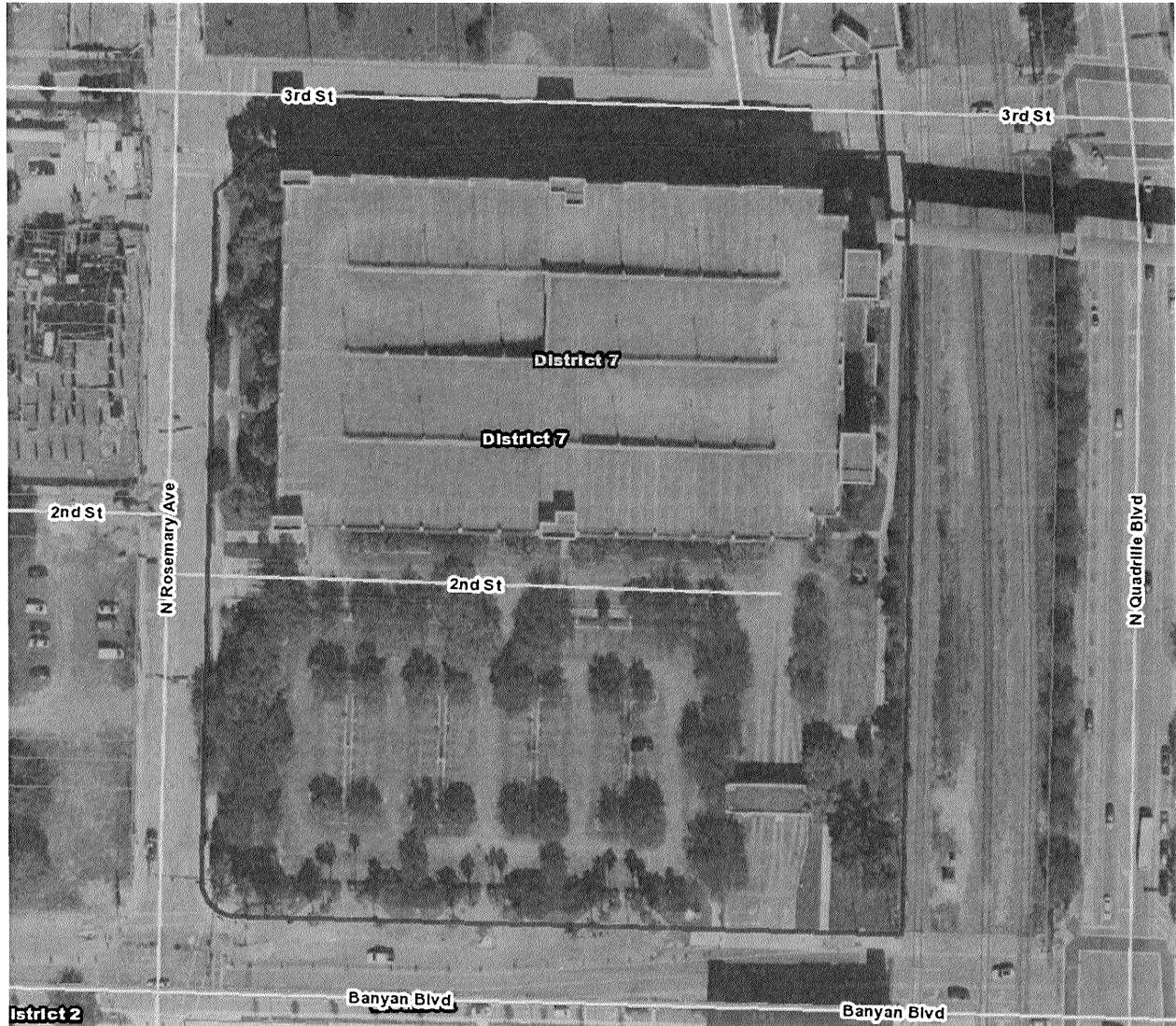

# ATTACHMENT # 1

**Location:** 421 3<sup>rd</sup> Street, West Palm Beach, Florida 33401 (SAPD Parking Lot)

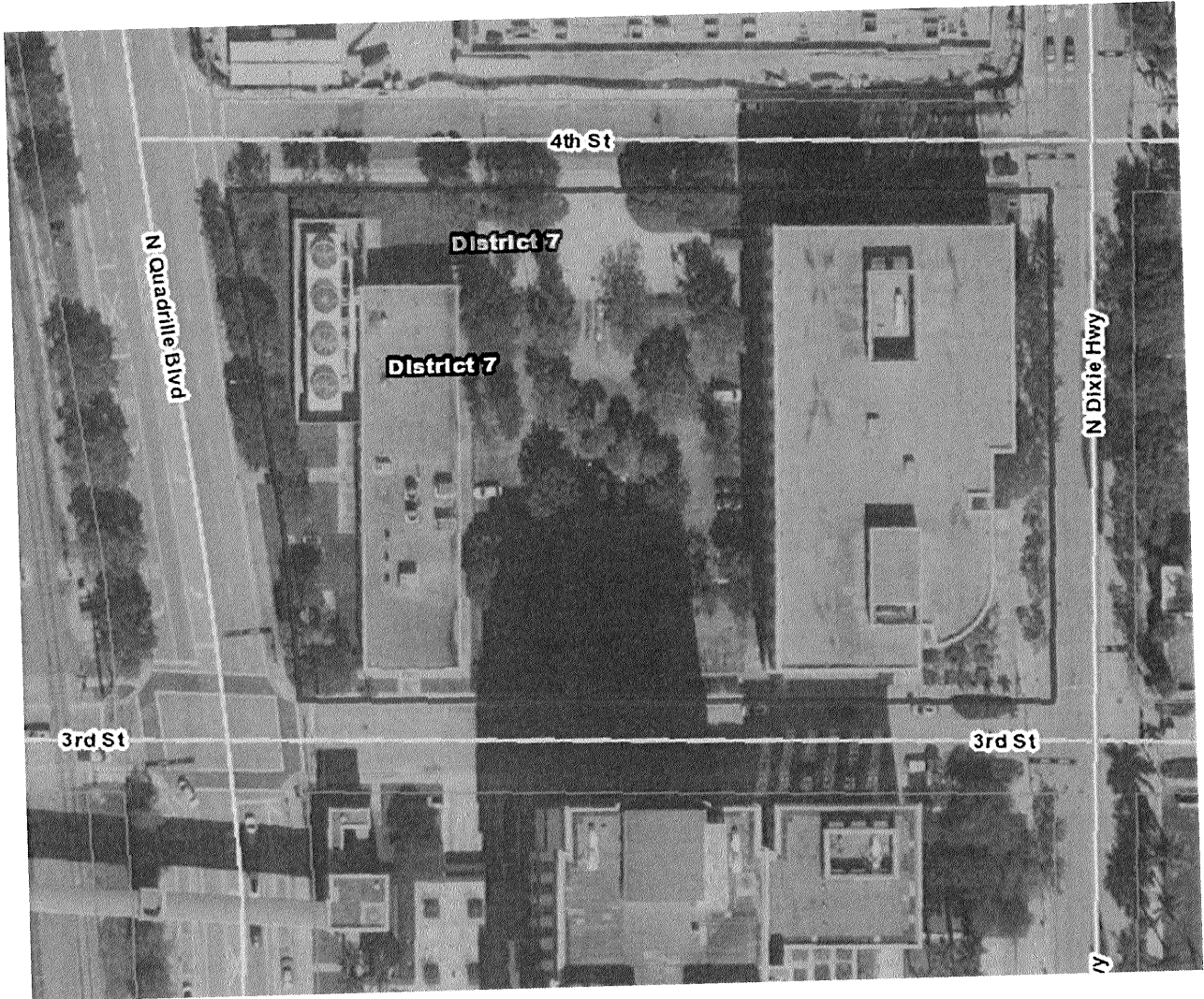

BUDGET AVAILABILITY STATEMENT

REQUEST DATE: 12/16/22 REQUESTED BY: Andy Gamble PHONE: 233-2055

PROJECT TITLE: Parking Garage access system upgrades: Judicial Center Parking Garage and SAPD parking lot (Same as CIP or IST, if applicable)

ORIGINAL CONTRACT AMOUNT: \$

IST PLANNING NO.:

REQUESTED AMOUNT: \$47,055.00

BCC RESOLUTION#:

eFDO #: 2020-010134

DATE:

CSA or CHANGE ORDER NUMBER:

MO 1/11/23

LOCATION: 505 Banyan Blvd, WPB and 420 4th St, WPB

BUILDING NUMBER: 1094

DESCRIPTION OF WORK/SERVICE LOCATION: Judicial Center and SAPD parking lots

PROJECT/W.O. NUMBER: 20157

CONSULTANT/CONTRACTOR: Amano McGann, Inc.

PROVIDE A BRIEF STATEMENT OF THE SCOPE OF SERVICES TO BE PROVIDED BY THE CONSULTANT/CONTRACTOR:

Replace existing gate arms, install 6 port panels and additional low voltage wiring, install additional revenue equipment and provide additional OPUS supplies, time extension for ISS to replace fiber network.

CONSTRUCTION	\$47,055.00 (supp 1)
PROFESSIONAL SERVICES	\$ NA
STAFF COSTS*	\$ NA
EQUIP. / SUPPLIES	\$ NA
CONTINGENCY	\$ NA
TOTAL	\$47,055.00



\* By signing this BAS your department agrees to these CID staff charges and your account will be charged upon receipt of this BAS by FD&O. Unless there is a change in the scope of work, no additional staff charges will be billed. If this BAS is for construction costs of \$250,000 or greater, staff charges will be billed as actual and reconciled at the end of the project. If the project requires Facilities Management or ESS staff your department will be billed actual hours worked upon project completion.

**BUDGET ACCOUNT NUMBER(S) (Specify distribution if more than one and order in which funds are to be used):**

FUND: 3804 DEPT: 411 UNIT: B675-DIAS OBJ: 4907

**IDENTIFY FUNDING SOURCE FOR EACH ACCOUNT: (check and provide detail for all that apply)**

- Ad Valorem (Amount \$ \_\_\_\_\_)  Infrastructure Sales Tax (Amount \$ \_\_\_\_\_)
- State (source/type: \_\_\_\_\_ Amount \$ \_\_\_\_\_)  Federal (source/type: \_\_\_\_\_ Amount \$ \_\_\_\_\_)
- Grant (source/type: \_\_\_\_\_ Amount \$ \_\_\_\_\_)  Impact Fees: (Amount \$ \_\_\_\_\_)
- Other (source/type: \_\_\_\_\_ Amount \$ \_\_\_\_\_)

Department: FD+O

BAS APPROVED BY: [Signature]

DATE 1/6/2023

ENCUMBRANCE NUMBER: \_\_\_\_\_

**CHANGE ORDER BRIEF**  
**PROJECT NAME: Parking Garage Access System Upgrades:**  
**Judicial Center Parking Garage and SAPD Parking Lot**  
**PROJECT NO. 20157**  
**DATE: 12/12/22**  
**CONTRACT NO. R2021-1070**

---

Prime Contractor ..... Amano McGann, Inc.

Change Order No. .... 01

Change Order Amount ..... \$47,055.00

Changed Contract Time ..... 225 calendar days

Description of Construction Change Proposals (CCPs):

1.	CCP #001:	Replace existing gate arms with lighted gate arms per FMD request ....	\$10,304.00
2.	CCP #002:	Install 20 ea. 6 port patch panels and additional low voltage wiring .....	\$5,300.00
3.	CCP #003:	Install additional revenue equipment and provide additional OPUS supplies.....	\$31,451.00
4.	CCP #004:	Time extension for ISS to replace fiber network .....	\$0.00
		<b>Total .....</b>	<b>\$47,055.00</b>

Reason for Change and Code:

1. CCP #001: (O) Owner requested different gate arms than what was specified.
2. CCP #002: (D) Changes in the ISS fiber required additional low voltage wiring and patch panels
3. CCP #003: (O) Owner requested additional revenue equipment and materials
4. CCP #004: (Q) Project was delayed 225 days for ISS to install new fiber network.

Reason-for-change codes

D = Differing Site Conditions	R = Request by another Agency/Outside Party
E = Errors/Omissions in Design	X = Other (Specify: _____)
O = Owner-Initiated	Z = Zoning/Code/Ordinance Change
Q = Quantity Adjustments	

Estimated premium value of errors/omissions for this change order: \$0.00

SUBMITTED:

2/1/23  
\_\_\_\_\_  
Andy Gamble, Project Manager Date  
Capital Improvements Division

If applicable:

API applicable to original contract: N/A

Original S/M/WBE participation for this Project: N/A%

S/M/WBE participation for this Change Order: N/A%

Revised S/M/WBE participation for Project after adjusted for Change Order: N/A%

Form Rev 12/21/19 Non-Federal

CHANGE ORDER HISTORY  
 PROJECT NAME: Parking Garage Access System Upgrades: Judicial Center Parking Garage and SAPD Parking Lot  
 PROJECT #20157

CO #	Description	Date Approved	Amount Approved by Director	Amount Approved by CRC	Amount Approved by BCC	Days Approved by Director	Days Approved by CRC	Days Approved by BCC	\$ S/M/WBE
1	CCP #001: Replace existing gate arms with lighted gate arms per FMD request \$10,304.00 CCP #002: Install 20 ea. 6 port patch panels and additional low voltage wiring \$5,300.00 CCP #003: Install additional revenue equipment and provide additional OPUS supplies \$31,451.00 CCP #004: Time extension for ISS to replace fiber network \$0.00	TBD			\$47,055.00			225	\$ -
<b>Totals</b>			\$0.00	\$0.00	\$47,055.00	0	0	225	\$0.00
			DIR + CRC DOLLARS TO DATE			DIR + CRC TOTAL DAYS TO DATE			
			\$0.00			0			

API Applicable to Original Contract: N/A  
 ORIGINAL CONTRACT PRICE \$ 336,974.60  
 PREVIOUS CHANGE ORDERS (N/A) \$ -  
 THIS CHANGE ORDER (01) \$ 47,055.00  
 ADJUSTED CONTRACT PRICE \$ 384,029.60

PALM BEACH COUNTY

CHANGE ORDER

ISSUED TO: Amano McGann, Inc. CHANGE ORDER NO.: 01
PROJECT NAME: Parking Garage Access System Upgrades: AMENDMENT NO: Sole Source
Judicial Center Parking Garage and SAPD Parking Lot REFERENCE CCP NO.: 001, 002, 003 & 004
PROJECT NO. 20157 RESOLUTION NO.: R2021-1070
DISTRICT NO.: 7

The completion date, contract price, and all terms, covenants, and conditions of the above referenced contract, except as duly modified by this and previous Change Orders, if any, shall remain in full force and effect.

DESCRIPTION OF CHANGE:

- 1. CCP #001: Replace existing gate arms with lighted gate arms per FMD request .....\$10,304.00
2. CCP #002: Install 20 ea. 6 port patch panels and additional low voltage wiring .....\$5,300.00
3. CCP #003: Install additional revenue equipment and provide additional OPUS supplies .....\$31,451.00
4. CCP #004: Time extension for ISS to replace fiber network .....\$0.00
Total.....\$47,055.00

CONTRACT PRICE

Original Contract Price: \$336,974.60
Previous CO # N/A through N/A: \$0.00
This Change Order No. 01: \$47,055.00
ADJUSTED Contract Price: \$384,029.60

COMPLETION DATE

Contract Completion Date will be increased by 225 calendar days.
Contract Notice to Proceed Date: 12/22/2021
Contract Substantial Completion Date: 2/20/2022
ADJUSTED Substantial Completion Date: 10/3/2022

CONTRACTOR

Execution of this change order acknowledges final settlement of, and releases, all claims for costs and time associated, directly or indirectly, with the above stated modification(s), including all claims for cumulative delays or disruptions resulting from, caused by, or incident to such modifications(s), and including any claim that the above stated modification(s) constitutes, in whole or part, a cardinal change to the contract. The above changes are accepted:

Amano McGann, Inc.
Contractor
By: Steven DiMarco
Print Name: Steven DiMarco
Title: President & CEO Date: 1-25-2023

DESIGN PROFESSIONAL

The above changes are recommended for approval by the Owner:

Design Professional
By:
Print Name:
Title: Date:

PALM BEACH COUNTY

Recommended By:
By: [Signature]
Title: Facilities Systems Date: 2/1/23
By: [Signature]
Title: Project Manager Date: 2-3-23
By: [Signature]
Title: Director, CID Date: 2-3-23
By: [Signature]
Title: Director, FD&O Date: 3-7-23
By: [Signature]
Title: Legal Sufficiency - CAO Date: 3/17/23

Approved By:
By:
Title: Mayor, BCC Date:



CCP # 1

Amano McGann, Inc  
 2699 Patton Rd  
 Roseville MN 55113

Quote	Q011233
Date	11/17/2022
Page	1

**Bill To:**

PALM BEACH COUNTY  
 BOARD OF CNTY COMMISSIONERS-PALM BE/  
 PO BOX 4036  
 WEST PALM BEACH FL 33402

**Ship To:**

PALM BEACH COUNTY  
 505 BANYAN BLVD  
 WEST PALM BEACH FL 33402

Purchase Order No.	Customer ID	Salesperson ID	Shipping Method	Payment Terms	Req Ship Date	Master No.
WILLIAM DART	0130329	HOUSE-013	BEST WAY	NET 30	0/0/0000	673,420
Quantity	Item Number	Description	UOM	Discount	Unit Price	Ext. Price
16	SERVICE PARTS	SERVICE PARTS LIGHTED LED GATE ARM KITS	EACH	\$0.00	\$509.00	\$8,144.00
16.0	013REG	FL REG-LABOR	HOUR	\$0.00	\$135.00	\$2,160.00

<b>Subtotal</b>	\$10,304.00
<b>Misc</b>	\$0.00
<b>Tax</b>	\$0.00
<b>Freight</b>	\$0.00
<b>Trade Discount</b>	\$0.00
<b>Total</b>	\$10,304.00

CCP # 2

Amano McGann, Inc  
 2699 Patton Rd  
 Roseville MN 55113

Quote	Q011237
Date	11/21/2022
Page	1

**Bill To:**

PALM BEACH COUNTY  
 BOARD OF CNTY COMMISSIONERS-PALM BEACH  
 PO BOX 4036  
 WEST PALM BEACH FL 33402

**Ship To:**

PALM BEACH COUNTY  
 505 BANYAN BLVD  
 WEST PALM BEACH FL 33402

Purchase Order No.	Customer ID	Salesperson ID	Shipping Method	Payment Terms	Req Ship Date	Master No.
WILLIAM DART	0130329	HOUSE-013	BEST WAY	NET 30	0/0/0000	673,632

Quantity	Item Number	Description	UOM	Discount	Unit Price	Ext. Price
1	SERVICE PARTS	SERVICE PARTS LABOR AND MATERIAL TO INSTALL LOW VOLTAGE AND 20 AMP PORT PATCH PANELS PER DRAWINGS	EACH	\$0.00	\$5,300.00	\$5,300.00

<b>Subtotal</b>	\$5,300.00
<b>Misc</b>	\$0.00
<b>Tax</b>	\$0.00
<b>Freight</b>	\$0.00
<b>Trade Discount</b>	\$0.00
<b>Total</b>	\$5,300.00

CCP # 2



3483 High Ridge Rd  
Boynton Beach, FL 33426

FL License# EC13004548  
Telephone 561-622-5880

Att: Mel Alvarez  
Amano McGann

January 20, 2022

**Re: Palm Beach County – Judicial Parking Garage – CO#1**

Scope of Work: Install CAT6 and low voltage per drawings (attached) using existing conduits. Provide 20 – 6 Port patch panels

Materials = \$1800.00  
Labor @ \$3500.00  
Total = \$5300.00

Note: Total does not include sales tax if applicable. While not likely, if the City of West Palm Beach requires a permit revision to show this work, there may be additional permit fees. Proposal is based on using existing conduits except at the NE exit lanes and the Rosemary entry/exit island.

Sincerely,  
Shad DiMaria,  
**Protect Video, Inc**

State Electrical Contractor  
Vendor Certification for County, State and US Government.  
Woman Owned WMBE Business

CCP #2

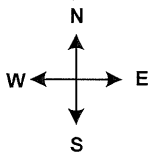

**Judicial Garage**  
**505 Banyan Blvd.**  
**WPB, FL.**

Protect Video "Work to Be Done" highlighted in Orange.

Note: Protect Video please provide a 2'x2'x1' concrete pad formed around existing low voltage card reader conduit and pad. Need 120 vac power conduit provided in center of pad from gate lane power circuit.

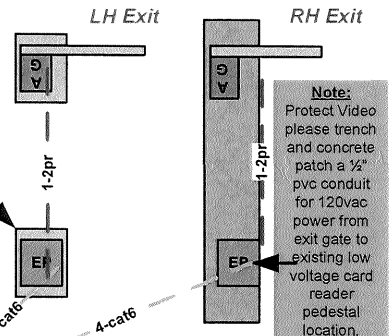

Note: Protect Video please trench and concrete patch a 1/2" pvc conduit for 120vac power from exit gate to existing low voltage card reader pedestal location.

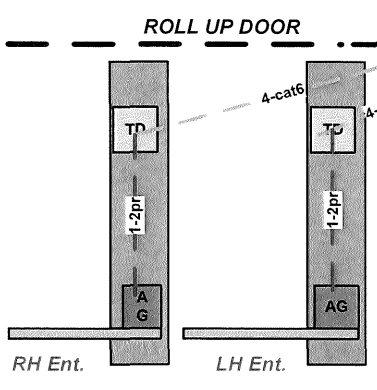

PBG Managed Switch

Note: Protect Video please provide 1-4 cond. shielded from each of the three parking office card readers back to corner of parking office server/network location if existing office reader wiring not located in server/network location already. 1-cat6 from desk location back to switch in office.

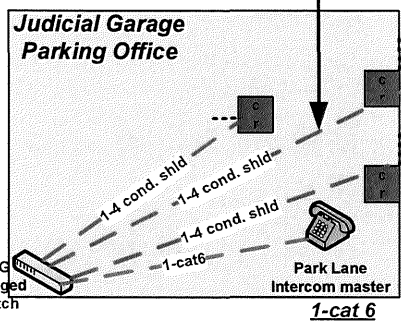

**PROTECT VIDEO CABLE RUNS WIRE LEGEND**

- 4-cat6 -----
- 1-4 cond. shld -----
- 1-2pr-22awg shld -----
- 4-cat6 -----
- 1-2pr -----
- 1-cat6 -----

ROLL UP DOOR

Note: Protect Video please provide 120vac power for new exit pay machines. A 120vac-20amp circuit be provided or if unavailable, power from same lane gate circuit can be used without an issue. EP location needs at least 3/4" conduit/trench and concrete patch to exit lane gate.

Note: Not an existing reader location, need Protect Video to please provide 2'x4' Red Dot box with lid with 1/2" conduit to existing reader box. Column box 46" mid box height.

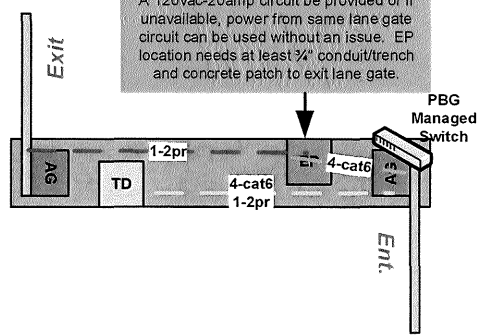

Note: Protect Video please provide 120vac power, in 1/2" pvc for new exit pay machines which will be installed at existing booth exit card reader locations. If 120vac-20amp circuit unavailable, power from same lane gate circuit can be used without an issue. Also provide a new 3/4" pvc conduit for low voltage network from booth to new EP location in "rough in" area from underneath EP, 24" from booth and 12" from road curb

**LEGEND**

SYMBOL	COUNT	DESCRIPTION
--------	-------	-------------

TD	5	TICKET DISPENSER
AG	10	AUTO GATE
EP	5	EXIT PARC
FC	2	FEE COMPUTER

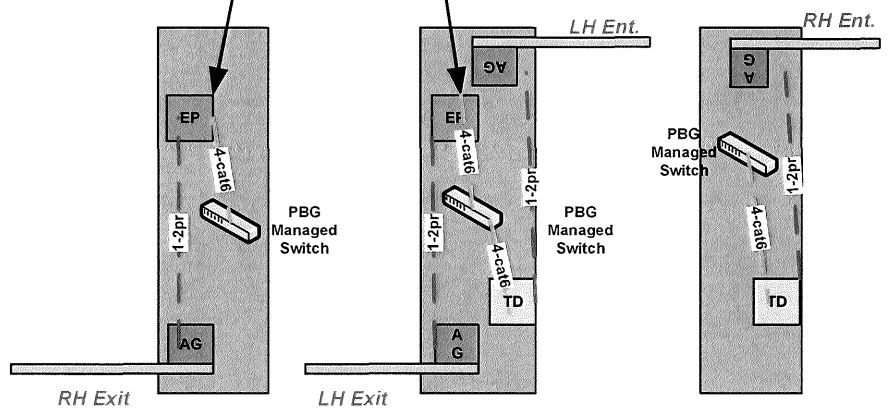

CCP # 3

**QUOTE 2394**

**Project Name: Palm Beach County Change Order 3**

SKU	Name	#	Price	Total
<b>Lane 1</b>				
MOVE5000	ARIA POS WINDCAVE READER	1	\$1,660.00	\$1,660.00
AGP-5910/A707	Fee Indicator, Wall Mount Wall mount/pedestal mount.	2	\$1,948.00	\$3,896.00
ARP-113400	OPUS Thermal Tickets Minimum order of 5,000 tickets.	300	\$53.00	\$15,900.00
CC-084400	Thermal Paper OPUS-4000/4800/7000 Series, one roll.	400	\$18.00	\$7,200.00
CC-087200	Thermal Receipt Paper OPUS-5000 Series, 80MMx83MM - 220', one roll.	200	\$10.00	\$2,000.00

**System Subtotal \$30,656.00**

Name	Price	Total
<b>Freight</b>		
FOB AMANO FORT LAUDERDALE OFFICE	\$795.00	\$795.00

**Freight Total \$795.00**

Name	Price	Total
<b>Applicable Tax</b>		
TAX EXEMPT	\$0.00	\$0.00

**Tax Total \$0.00**

--

CCP # 3

<b>Grand Total: \$31,451.00</b>

**From:** PTS@co.palm-beach.fl.us  
**Sent:** Tuesday, July 5, 2022 7:18 AM  
**To:** Andrew Gamble; Shawn Bobo; Vince Perratore  
**Subject:** PTS - Work Order# 120626 Requested Production Date has been changed.

## Palm Beach County Service Request System

Notification(s) for your review

Requested Production Date has been changed from 06/30/2022 to 09/30/2022 for WO# 120626.

<b>WO#</b>	120626
<b>Title:</b>	FDO CID Judicial Center garage and SAPD Parking Lots Network switches and fiber for 61 data drops
<b>Description:</b>	Provide new network switches and fiber to support 59 data drops at the Judicial Center garage and 2 data drops at the SAPD Parking Lot (see attached)

Please [click here](#) to log into SRS System. (If it is not already open.)

Email sent by SRS System. This is an auto generated email, please do not reply.

**From:** PTS@co.palm-beach.fl.us  
**Sent:** Monday, May 2, 2022 3:40 PM  
**To:** Andrew Gamble; Shawn Bobo; Vince Perratore  
**Subject:** PTS - Work Order# 120626 Requested Production Date has been changed.

## Palm Beach County Project Tracking System

Notification(s) for your review

Requested Production Date has been changed from 04/30/2022 to 06/30/2022 for WO# 120626.

<b>WO#</b>	120626
<b>Title:</b>	FDO CID Judicial Center garage and SAPD Parking Lots Network switches and fiber for 61 data drops
<b>Description:</b>	Provide new network switches and fiber to support 59 data drops at the Judicial Center garage and 2 data drops at the SAPD Parking Lot (see attached)

Please [click here](#) to log into PTS System. (If it is not already open.)

Email sent by PTS System. This is an auto generated email, please do not reply.



**From:** PTS@co.palm-beach.fl.us  
**Sent:** Wednesday, March 2, 2022 2:44 PM  
**To:** Andrew Gamble; Shawn Bobo; Vince Perratore  
**Subject:** PTS - Work Order# 120626 Requested Production Date has been changed.

## Palm Beach County Project Tracking System

Notification(s) for your review

Requested Production Date has been changed from 02/28/2022 to 04/30/2022 for WO# 120626.

<b>WO#</b>	120626
<b>Title:</b>	FDO CID Judicial Center garage and SAPD Parking Lots Network switches and fiber for 61 data drops
<b>Description:</b>	Provide new network switches and fiber to support 59 data drops at the Judicial Center garage and 2 data drops at the SAPD Parking Lot (see attached)

Please [click here](#) to log into PTS System. (If it is not already open.)

Email sent by PTS System. This is an auto generated email, please do not reply.

**From:** PTS@co.palm-beach.fl.us  
**Sent:** Monday, December 20, 2021 10:49 AM  
**To:** Andrew Gamble; Shawn Bobo; Vince Perratore  
**Subject:** PTS - Work Order# 120626 Requested Production Date has been changed.

## Palm Beach County Project Tracking System

Notification(s) for your review

Requested Production Date has been changed from 01/05/2022 to 02/28/2022 for WO# 120626.

WO#	120626
Title:	FDO CID Provide network switches and fiber for 61 data drops (Judicial Center garage and SAPD parking lot)
Description:	Provide new network switches and fiber to support 59 data drops at the Judicial Center garage and 2 data drops at the SAPD Parking Lot (see attached)

Please [click here](#) to log into PTS System. (If it is not already open.)

Email sent by PTS System. This is an auto generated email, please do not reply.

**From:** PTS@pbcgov.org  
**Sent:** Friday, November 19, 2021 10:18 AM  
**To:** Andrew Gamble; Shawn Bobo; Vince Perratore  
**Subject:** PTS - WO# 120626 - Status Changed.

## Palm Beach County Project Tracking System

Notification(s) for your review

The status of WO# 120626, has been changed to Work in Progress.

WO#	120626
WO Title:	FDO CID Provide network switches and fiber for 61 data drops (Judicial Center garage and SAPD parking lot)
WO Description:	Provide new network switches and fiber to support 59 data drops at the Judicial Center garage and 2 data drops at the SAPD Parking Lot (see attached)

Please [click here](#) to log into PTS System. (If it is not already open.)

Email sent by PTS System. This is an auto generated email, please do not reply.



# CERTIFICATE OF LIABILITY INSURANCE

DATE (MM/DD/YYYY)  
03/06/2023

**THIS CERTIFICATE IS ISSUED AS A MATTER OF INFORMATION ONLY AND CONFERS NO RIGHTS UPON THE CERTIFICATE HOLDER. THIS CERTIFICATE DOES NOT AFFIRMATIVELY OR NEGATIVELY AMEND, EXTEND OR ALTER THE COVERAGE AFFORDED BY THE POLICIES BELOW. THIS CERTIFICATE OF INSURANCE DOES NOT CONSTITUTE A CONTRACT BETWEEN THE ISSUING INSURER(S), AUTHORIZED REPRESENTATIVE OR PRODUCER, AND THE CERTIFICATE HOLDER.**

**IMPORTANT: If the certificate holder is an ADDITIONAL INSURED, the policy(ies) must have ADDITIONAL INSURED provisions or be endorsed. If SUBROGATION IS WAIVED, subject to the terms and conditions of the policy, certain policies may require an endorsement. A statement on this certificate does not confer rights to the certificate holder in lieu of such endorsement(s).**

<b>PRODUCER</b> Willis of New Jersey, Inc. c/o 26 Century Blvd P.O. Box 305191 Nashville, TN 372305191 USA	<b>CONTACT NAME:</b> Willis Towers Watson Certificate Center <b>PHONE (A/C, No, Ext):</b> 1-877-945-7378 <b>FAX (A/C, No):</b> 1-888-467-2378 <b>E-MAIL ADDRESS:</b> certificates@willis.com
<b>INSURER(S) AFFORDING COVERAGE</b>	
<b>INSURER A:</b> Tokio Marine America Insurance Company <b>NAIC #</b> 10945	
<b>INSURER B:</b> Trans Pacific Insurance Company <b>NAIC #</b> 41238	
<b>INSURER C:</b>	
<b>INSURER D:</b>	
<b>INSURER E:</b>	
<b>INSURER F:</b>	

**COVERAGES**      **CERTIFICATE NUMBER:** W28267937      **REVISION NUMBER:**

**THIS IS TO CERTIFY THAT THE POLICIES OF INSURANCE LISTED BELOW HAVE BEEN ISSUED TO THE INSURED NAMED ABOVE FOR THE POLICY PERIOD INDICATED. NOTWITHSTANDING ANY REQUIREMENT, TERM OR CONDITION OF ANY CONTRACT OR OTHER DOCUMENT WITH RESPECT TO WHICH THIS CERTIFICATE MAY BE ISSUED OR MAY PERTAIN, THE INSURANCE AFFORDED BY THE POLICIES DESCRIBED HEREIN IS SUBJECT TO ALL THE TERMS, EXCLUSIONS AND CONDITIONS OF SUCH POLICIES. LIMITS SHOWN MAY HAVE BEEN REDUCED BY PAID CLAIMS.**

INSR LTR	TYPE OF INSURANCE	ADDL INSD	SUBR WVD	POLICY NUMBER	POLICY EFF (MM/DD/YYYY)	POLICY EXP (MM/DD/YYYY)	LIMITS
A	<input checked="" type="checkbox"/> <b>COMMERCIAL GENERAL LIABILITY</b> <input type="checkbox"/> CLAIMS-MADE <input checked="" type="checkbox"/> OCCUR  GENL AGGREGATE LIMIT APPLIES PER: <input type="checkbox"/> POLICY <input checked="" type="checkbox"/> PRO-JECT <input checked="" type="checkbox"/> LOC OTHER:	Y		CPP 6404150-12	09/01/2022	09/01/2023	EACH OCCURRENCE \$ 1,000,000 DAMAGE TO RENTED PREMISES (Ea occurrence) \$ 1,000,000 MED EXP (Any one person) \$ 10,000 PERSONAL & ADV INJURY \$ 1,000,000 GENERAL AGGREGATE \$ 2,000,000 PRODUCTS - COMP/OP AGG \$ 2,000,000 Policy Aggregate \$ 5,000,000
A	<b>AUTOMOBILE LIABILITY</b> <input checked="" type="checkbox"/> ANY AUTO <input type="checkbox"/> OWNED AUTOS ONLY <input type="checkbox"/> SCHEDULED AUTOS <input type="checkbox"/> HIRED AUTOS ONLY <input type="checkbox"/> NON-OWNED AUTOS ONLY <input type="checkbox"/> AUTOS ONLY			CA 6404084-12	09/01/2022	09/01/2023	COMBINED SINGLE LIMIT (Ea accident) \$ 1,000,000 BODILY INJURY (Per person) \$ BODILY INJURY (Per accident) \$ PROPERTY DAMAGE (Per accident) \$ \$
	<b>UMBRELLA LIAB</b> <input type="checkbox"/> OCCUR <b>EXCESS LIAB</b> <input type="checkbox"/> CLAIMS-MADE  DED    RETENTION \$						EACH OCCURRENCE \$ AGGREGATE \$ \$
B	<b>WORKERS COMPENSATION AND EMPLOYERS' LIABILITY</b> ANY PROPRIETOR/PARTNER/EXECUTIVE OFFICER/MEMBER EXCLUDED? (Mandatory in NH) If yes, describe under DESCRIPTION OF OPERATIONS below	Y/N No	N/A	WC 6409827-05	09/01/2022	09/01/2023	<input checked="" type="checkbox"/> PER STATUTE <input type="checkbox"/> OTH-ER E.L. EACH ACCIDENT \$ 1,000,000 E.L. DISEASE - EA EMPLOYEE \$ 1,000,000 E.L. DISEASE - POLICY LIMIT \$ 1,000,000

**DESCRIPTION OF OPERATIONS / LOCATIONS / VEHICLES (ACORD 101, Additional Remarks Schedule, may be attached if more space is required)**

**PALM BEACH COUNTY PURCHASING DEPARTMENT**

Palm Beach County Board of County Commissioners, a political subdivision of the State of Florida, its officers, employees and agents, c/o Facilities Development & Operations Department are included as Additional Insureds as respects to General Liability.

<b>CERTIFICATE HOLDER</b>  Palm Beach County c/o Capital Improvements Division 2633 Vista Parkway West Palm Beach, FL 33411-5603	<b>CANCELLATION</b>  SHOULD ANY OF THE ABOVE DESCRIBED POLICIES BE CANCELLED BEFORE THE EXPIRATION DATE THEREOF, NOTICE WILL BE DELIVERED IN ACCORDANCE WITH THE POLICY PROVISIONS.  AUTHORIZED REPRESENTATIVE  
---	--

© 1988-2016 ACORD CORPORATION. All rights reserved.

ACORD 25 (2016/03)

The ACORD name and logo are registered marks of ACORD

SR ID: 23829653

BATCH: 2878960

AGENCY CUSTOMER ID: \_\_\_\_\_

LOC #: \_\_\_\_\_



### ADDITIONAL REMARKS SCHEDULE

AGENCY Willis of New Jersey, Inc.		NAMED INSURED Amano McGann, Inc 3650 Park Central Blvd. North Pompano Beach, FL 33064	
POLICY NUMBER See Page 1		EFFECTIVE DATE: See Page 1	
CARRIER See Page 1	NAIC CODE See Page 1		

**ADDITIONAL REMARKS**

THIS ADDITIONAL REMARKS FORM IS A SCHEDULE TO ACORD FORM,  
FORM NUMBER: 25 FORM TITLE: Certificate of Liability Insurance

General Liability policy shall be Primary with any other insurance in force for or which may be purchased by Additional Insureds.

THIS ENDORSEMENT CHANGES THE POLICY. PLEASE READ IT CAREFULLY.

**ADDITIONAL INSURED – OWNERS, LESSEES OR CONTRACTORS – SCHEDULED PERSON OR ORGANIZATION**

This endorsement modifies insurance provided under the following:

COMMERCIAL GENERAL LIABILITY COVERAGE PART  
SCHEDULE

Name Of Additional Insured Person(s) Or Organization(s)	Location(s) Of Covered Operations
CLIENTS TO WHOM A NAMED INSURED PROVIDES SERVICES UNDER A WRITTEN SALES OR SERVICE CONTRACT.	INSTALLATION, SERVICING OR REPAIRS IN THE "COVERAGE TERRITORY".

Information required to complete this Schedule, if not shown above, will be shown in the Declarations.

**A. Section II – Who Is An Insured** is amended to include as an additional insured the person(s) or organization(s) shown in the Schedule, but only with respect to liability for "bodily injury", "property damage" or "personal and advertising injury" caused, in whole or in part, by:

1. Your acts or omissions; or
2. The acts or omissions of those acting on your behalf;

in the performance of your ongoing operations for the additional insured(s) at the location(s) designated above.

However:

1. The insurance afforded to such additional insured only applies to the extent permitted by law; and
2. If coverage provided to the additional insured is required by a contract or agreement, the insurance afforded to such additional insured will not be broader than that which you are required by the contract or agreement to provide for such additional insured.

**B.** With respect to the insurance afforded to these additional insureds, the following additional exclusions apply:

This insurance does not apply to "bodily injury" or "property damage" occurring after:

1. All work, including materials, parts or equipment furnished in connection with such work, on the project (other than service, maintenance or repairs) to be performed by or on behalf of the additional insured(s) at the location of the covered operations has been completed; or
2. That portion of "your work" out of which the injury or damage arises has been put to its intended use by any person or organization other than another contractor or subcontractor engaged in performing operations for a principal as a part of the same project.

THIS ENDORSEMENT CHANGES THE POLICY. PLEASE READ IT CAREFULLY.

**ADDITIONAL INSURED – OWNERS, LESSEES OR CONTRACTORS – COMPLETED OPERATIONS**

This endorsement modifies insurance provided under the following:

COMMERCIAL GENERAL LIABILITY COVERAGE PART  
PRODUCTS/COMPLETED OPERATIONS LIABILITY COVERAGE PART

SCHEDULE

Name Of Additional Insured Person(s) Or Organization(s)	Location And Description Of Completed Operations
CLIENTS TO WHOM A NAMED INSURED PROVIDES SERVICE UNDER A WRITTEN SALES OR SERVICE CONTRACT.	INSTALLATION, SERVICING OR REPAIRS IN THE "COVERAGE TERRITORY"
Information required to complete this Schedule, if not shown above, will be shown in the Declarations.	

A. Section II – Who Is An Insured is amended to include as an additional insured the person(s) or organization(s) shown in the Schedule, but only with respect to liability for "bodily injury" or "property damage" caused, in whole or in part, by "your work" at the location designated and described in the Schedule of this endorsement performed for that additional insured and included in the "products-completed operations hazard".

However:

1. The insurance afforded to such additional insured only applies to the extent permitted by law; and
2. If coverage provided to the additional insured is required by a contract or agreement, the insurance afforded to such additional insured will not be broader than that which you are required by the contract or agreement to provide for such additional insured.

B. With respect to the insurance afforded to these additional insureds, the following is added to Section III – Limits Of Insurance:

If coverage provided to the additional insured is required by a contract or agreement, the most we will pay on behalf of the additional insured is the amount of insurance:

1. Required by the contract or agreement; or
  2. Available under the applicable Limits of Insurance shown in the Declarations;
- whichever is less.

This endorsement shall not increase the applicable Limits of Insurance shown in the Declarations.

**THIS ENDORSEMENT CHANGES THE POLICY. PLEASE READ IT CAREFULLY.**

**PRIMARY AND NONCONTRIBUTORY –  
OTHER INSURANCE CONDITION**

This endorsement modifies insurance provided under the following:

COMMERCIAL GENERAL LIABILITY COVERAGE PART  
PRODUCTS/COMPLETED OPERATIONS LIABILITY COVERAGE PART

The following is added to the **Other Insurance Condition** and supersedes any provision to the contrary:

**Primary And Noncontributory Insurance**

This insurance is primary to and will not seek contribution from any other insurance available to an additional insured under your policy provided that:

(1) The additional insured is a Named Insured under such other insurance; and

(2) You have agreed in writing in a contract or agreement that this insurance would be primary and would not seek contribution from any other insurance available to the additional insured.