

PALM BEACH COUNTY
BOARD OF COUNTY COMMISSIONERS
AGENDA ITEM SUMMARY

Meeting Date: May 5, 2026 Consent [X] Regular []
Public Hearing []

Department: Water Utilities Department

I. EXECUTIVE BRIEF

Motion and Title: Staff recommends motion to approve: Change Order (CO) No. 4 to the Green Cay Phase 2 Progressive Design-Build (Project) with CDM Constructors Inc. (CDM) in the amount of \$4,997,748.80.

Summary: The Board of County Commissioners (BCC) approved the Palm Beach County Water Utilities Department (PBCWUD) Contract (R2021-1248) and Contract Amendment No. 1 (R2023-1907) with CDM. The Project includes the design and construction of a new Water Purification Facility (WPF) located at the Southern Region Water Reclamation Facility (SRWRF) capable of treating two (2) million gallons per day (MGD) of purified water and expandable to four (4) MGD. Additionally, the Project includes a new state-of-the-art education/learning facility co-located with the WPF, a new 63-acre public park with purified waterways located at the corner of Jog and Flavor Pict Road, and two (2) new surficial aquifer production water wells and associated water transmission lines. CDM has initiated construction for the Project. CO No. 4, in the amount of \$4,997,748.80, is for installation of two (2) more production wells, an extension of the raw water main, material change to the picnic tables, revisions to drainage and irrigation systems, and paint modification for the chemical canopy.

The Project has overwhelming support from local, state, and federal agencies and successfully secured the following grant funding: \$11,792,400 from South Florida Water Management District Alternative Water Supply FY2023 (R2023-1113), FY2024 (R2024-1425) and FY2025 (R2025-1493) (AWS Grant), \$3,000,000 from Florida House of Representatives Appropriation FY2023 (R2024-0556), and \$10,500,000 from American Rescue Plan Act FY2022. PBCWUD has received award notifications for additional grant funding and is actively pursuing other opportunities.

The Contract Amendment No. 1 was presented to the Goal Setting Committee (Committee) on June 21, 2022, and the Committee established an Affirmative Procurement Initiative (API) for Phase 2 Construction Services of a minimum mandatory 20% Small Business Enterprise (SBE) subcontracting goal. CDM committed to 13.28% SBE participation. A subcontracting waiver request was approved by the Office of Equal Business Opportunity under Contract Amendment No. 1. The SBE participation for this CO No. 4 is 0.45%. To date, the overall participation achieved on this Contract is 18.13%. CDM is headquartered in Boston, Massachusetts, but maintains an office in Palm Beach County from which the majority of the work will be undertaken. CO No. 4 is included in the PBCWUD FY 2026 Budget and grant funding. (PBCWUD Project No. 20-036) District 5 (MWJ)

Background and Justification: PBCWUD is the third largest utility in the state of Florida providing drinking water, wastewater and reclaimed water to approximately 600,000 customers throughout Palm Beach County. As the population within Palm Beach County and Florida grows, PBCWUD has recognized the challenges utilities will face in the future with respect to traditional drinking water sources. To this end, PBCWUD has undertaken the Project. The WPF will treat source water from SRWRF supplying purified water to Green Cay Phase 2 Park to replenish regional groundwater, supporting PBCWUD's strategic goals of becoming a sustainable and best-in-class utility.

Attachments:

- 1. Two (2) Originals of Change Order No. 4
2. Location Map
3. Ebix Compliance Summary Report

Recommended By: Ali Bayat 4/20/2026
Department Director Date
Approved By: [Signature] 4/20/26
Chief Deputy County Administrator Date

II. FISCAL IMPACT ANALYSIS

A. Five Year Summary of Fiscal Impact:

Fiscal Years	2026	2027	2028	2029	2030
Capital Expenditures	<u>\$4,997,749</u>	<u>0</u>	<u>0</u>	<u>0</u>	<u>0</u>
Operating Costs	<u>0</u>	<u>0</u>	<u>0</u>	<u>0</u>	<u>0</u>
External Revenues	<u>(\$1,487,500)</u>	<u>0</u>	<u>0</u>	<u>0</u>	<u>0</u>
Program Income (County)	<u>0</u>	<u>0</u>	<u>0</u>	<u>0</u>	<u>0</u>
In-Kind Match County	<u>0</u>	<u>0</u>	<u>0</u>	<u>0</u>	<u>0</u>
NET FISCAL IMPACT	<u>\$3,510,249</u>	<u>0</u>	<u>0</u>	<u>0</u>	<u>0</u>
# ADDITIONAL FTE POSITIONS (Cumulative)	<u>0</u>	<u>0</u>	<u>0</u>	<u>0</u>	<u>0</u>
Budget Account No.:	Fund <u>4011</u>	Dept <u>721</u>	Unit <u>W050</u>	Object <u>6545</u>	
	<u>4011</u>	<u>721</u>	<u>W056</u>	<u>6545</u>	

Is Item Included in Current Budget? Yes X No

Is this item using Federal Funds? Yes X No

Is this item using State Funds? Yes X No

Reporting Category N/A

B. Recommended Sources of Funds/Summary of Fiscal Impact:

One-time expenditure from user fees, connection fees, and balance brought forward and a portion of SFWMD Grant Agreement 460005246 - \$1,487,500 (R2025-1493). There is a net fiscal impact of \$3,510,249

C. Department Fiscal Review: Bony Foreman

III. REVIEW COMMENTS

A. OFMB Fiscal and/or Contract Development and Control Comments:

[Signature] 4/20/26
OFMB

[Signature] 4/22/26
Contract Development and Control

B. Legal Sufficiency:
[Signature] 4/23/26
Assistant County Attorney

C. Other Department Review:

Department Director

This summary is not to be used as a basis for payment.

CHANGE ORDER NO. 4
Palm Beach County Water Utilities Department
Progressive Design-Build Agreement
GREEN CAY PHASE 2 PROGRESSIVE DESIGN-BUILD
Resolution No. R2021-1248 Contract Dated September 14, 2021
Amendment No. 1 Resolution No. R2023-1907 Contract Dated December 19, 2023

Project Title: Green Cay Phase 2 Progressive Design-Build

PBCWUD Project No.: 20-036

Contractor: CDM Constructors Inc.

Address: 75 State Street, Suite 701, Boston MA 02109

Budget Line Item No.: 4011-721-W050-6545, 4011-721-W056-6545

District: 5

Notice to Proceed: September 14, 2021; December 22, 2023 (Amendment No. 1)

The Contract provides for 13.28 % SBE participation. This Change Order includes 0.45 % overall SBE participation. The cumulative SBE participation, including this Change Order is 18.13 %.

The Contract and this Change Order is subject to the County Emergency Ordinance 2025-014, approved by the Board of County Commissioners on June 3, 2025.

You are directed to make the following changes in this contract to incorporate the Potential Change Orders (PCO):

PCO 008	– Additional Production Wells (3W-34) & (3W-36)	\$ 4,938,170.64
PCO 009	– Chemical Canopy - Tnemec Paint	\$13,164.60
PCO 010	– Balance of Park Picnic Tables	\$19,675.11
PCO 011	– Water Purification Facility Irrigation Upgrades	\$24,738.45
Total:		<u>\$4,997,748.80</u>

For PCO 008 Additional Production Wells (3W-34) & (3W-36), Design-Build Entity shall begin work within ten (10) calendar days from the issuance of Notice to Proceed (NTP). Execution of PCO 008 will be accomplished as follows from the issuance of the NTP:

Substantial Completion: **300** Calendar Days
Final Construction Completion: **330** Calendar Days

Liquidated damages for PCO 008 will apply as follows:

\$500.00 per day past **Substantial Completion date.**
\$250.00 per day past **Final Completion date.**

PCO 008 includes an allowance of \$250,000 for work to be completed by Florida Power & Light (FPL), Owner's utility provided. It is expressly acknowledged and agreed that the allowance is not a representation or guarantee that the work within the allowance can be performed for the allowance value, and Owner will issue a change order for the actual amount incurred for FPL's work, along with an extension of time for any delays caused by FPL.

Please see attachment A for breakdown and summary of the cost and time impacts, as well as attachment F for the supporting documentation for the above PCO.

All Attachments to this Change Order are made a part of this Change Order and incorporated herein.



NOT VALID UNTIL SIGNED BY BOTH OWNER AND ENGINEER. SIGNATURE OF THE CONTRACTOR INDICATES THEIR AGREEMENT HERewith INCLUDING ANY ADJUSTMENT IN THE CONTRACT SUM OR CONTRACT TIME, AND NO ADDITIONAL COST OR TIME INDICATED HEREIN WILL BE RELATED TO THIS CHANGE

CHANGE ORDER NO. 4
Palm Beach County Water Utilities Department
Progressive Design-Build Agreement
GREEN CAY PHASE 2 PROGRESSIVE DESIGN-BUILD
Resolution No. R2021-1248 Contract Dated September 14, 2021
Amendment No. 1 Resolution No. R2023-1907 Contract Dated December 19, 2023

The Original Contract Sum was.....	<u>\$99,220,507.16</u>
Net Change by previous Change Order.....	<u>(\$7,919,451.64)</u>
The Contract Sum prior to this Change Order was.....	<u>\$91,301,055.52</u>
The Contract Sum will be increased/decreased by this Change Order.....	<u>\$4,997,748.80</u>
The New Contract Sum indicating this Change Order will be.....	<u>\$96,298,804.32</u>
The Date of Substantial Water Purification Facility Completion prior to this Change Order was ...	<u>June 12, 2026</u>
The Date of Substantial Park Completion prior to this Change Order was	<u>June 3, 2026</u>
The Date of Final Completion prior to this Change Order was	<u>October 7, 2026</u>
The Date of Substantial Water Purification Facility Contract Time will be increased/decreased by.....	<u>0 Days</u>
The Date of Substantial Park Contract Time will be increased/decreased by.....	<u>0 Days</u>
The Date of Final Completion Contract Time will be increased/decreased by.....	<u>0 Days</u>
The Date of Substantial Water Purification Facility Completion including this Change Order.....	<u>June 12, 2026</u>
The Date of Substantial Park Completion including this Change Order.....	<u>June 3, 2026</u>
The Date of Final Completion including this Change Order.....	<u>October 7, 2026</u>

CHANGE ORDER NO. 4
 Palm Beach County Water Utilities Department
 Progressive Design-Build Agreement
 GREEN CAY PHASE 2 PROGRESSIVE DESIGN-BUILD
 Resolution No. R2021-1248 Contract Dated September 14, 2021
 Amendment No. 1 Resolution No. R2023-1907 Contract Dated December 19, 2023

Execution of this change order acknowledges final settlement of, and releases, all claims for costs and time associated, directly or indirectly, with the above stated modification(s), including all claims for cumulative delays or disruptions resulting from, caused by, or incident to such modification(s), and including any claim that the above stated modification(s) constitutes, in whole or part, a cardinal change to the contract.

CDM Constructors, Inc. CONTRACTOR 101 Southhall Lane Suite 200 Maitland FL 32751 ADDRESS  SIGNATURE Tommy Floyd PRINT NAME Senior Vice President TITLE 04.02.2026 DATE	Palm Beach County Water Utilities Department ENGINEER 8100 Forest Hill Blvd. West Palm Beach, FL 33413 ADDRESS  SIGNATURE Jane House PRINT NAME Director of Engineering TITLE 4/10/2026 DATE	Palm Beach County Board of County Commissioners OWNER 301 N. Olive Avenue West Palm Beach, FL 33401 ADDRESS [Signature] SIGNATURE Sara Baxter PRINT NAME Mayor TITLE DATE
--	--	---

STATE OF FLORIDA
 COUNTY OF Volusia

The foregoing instrument was acknowledged before me by means of physical presence or online notarization this 2nd day of April, 2026 by Tommy Floyd who is personally known to me or has produced _____ as identification.

 (Signature of Notary Public – State of Florida)

Debra A Norman
 (Print, Type, or Stamp Commissioned Name of Notary Public)

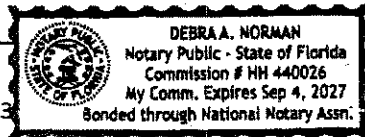

Approved as to Form and Legal Sufficiency

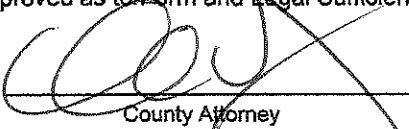
By: 
 County Attorney

Attest: Mike Caruso, Clerk of the Circuit Court & Comptroller, Palm Beach County

By: _____
 Deputy Clerk

CHANGE ORDER NO. 4
Palm Beach County Water Utilities Department
Progressive Design-Build Agreement
GREEN CAY PHASE 2 PROGRESSIVE DESIGN-BUILD
Resolution No. R2021-1248 Contract Dated September 14, 2021
Amendment No. 1 Resolution No. R2023-1907 Contract Dated December 19, 2023

LIST OF ATTACHMENTS

ATTACHMENT A	Change Order Summary and Categorization
ATTACHMENT B	Change Order Additions/Deletions Summary
ATTACHMENT C	OSBD Schedule 1 and Schedule 2
ATTACHMENT D	Location Map
ATTACHMENT E	Bond Rider (if applicable)
ATTACHMENT F	Supporting Documentation

REVISED 07-08-25

ATTACHMENT B

CHANGE ORDER ADDITIONS/DELETIONS SUMMARY

Project Title: Green Cay Phase 2 Progressive Design-Build
 Contractor: CDM Constructors Inc.
 PBCWUD Project No.: 20-036
 Resolution No.: R2021-1248, R2023-1907
 Date Approved: 09/14/2021, 12/22/2024
 Contract Amount: \$91,301,055.52

APPROVAL LIMITS:

Department Head

Contract Review Committee

Amount/Days

Amount/Days

Individual C.O.
Cumulative C.O.

\$100,000.00 - 180 Days
\$375,000.00¹ - 180 Days

\$200,000.00 - 180 Days
\$375,000.00¹ - 180 Days

C.O. NO.	DATE APPROVED	NET CHANGE ²	DEPARTMENT HEAD (ADDS PLUS DEDUCTS) ³		CONTRACT REVIEW COMMITTEE (ADDS PLUS DEDUCTS) ³		TOTAL DEPT. HEAD & CONTRACT REVIEW COMM. (ADDS PLUS DEDUCTS) ³		BOARD OF COUNTY COMMISSIONERS (ADDS PLUS DEDUCTS) ³		TOTALS
			AMOUNT	DAYS	AMOUNT	DAYS	AMOUNT	DAYS	AMOUNT	DAYS	
1		\$0.00	\$0.00	0			\$0.00	0			\$0.00
2		(\$9,468,202.25)	(\$9,468,202.25)	0			(\$9,468,202.25)	0			(\$9,468,202.25)
3		\$1,548,750.61							\$1,632,634.31	58	\$1,548,750.61
4		\$4,997,748.80							\$4,997,748.80	0	\$4,997,748.80
		(\$2,921,702.84)	(\$9,468,202.25)	0	\$		(\$9,468,202.25)		\$6,630,383.11	58	(\$2,921,702.84)

NOTES:

1. Per PPM #CW-F-050, upon approval of the C.O. in the cumulative amount of \$375,000.00 or 10% of the original contract value must submit a Receive and File to the Board of County Commissioners and the cumulative value is reset
2. Net Change reflects the net amount of additions plus deductions.
3. Adds plus Deducts reflects the absolute value of unrelated changes for use in determining the approval authority for the Change Order.

ATTACHMENT C
OSBD SCHEDULE 1

OFFICE OF SMALL BUSINESS DEVELOPMENT COMPLIANCE PROGRAMS

OSBD SCHEDULE 1

SOLICITATION/PROJECT/BID NAME: Green Cay Phase 2 Progressive Design-Build

SOLICITATION/PROJECT/BID NO.: WUD Project No. 20-036

SOLICITATION OPENING/SUBMITTAL DATE: December 17, 2020

COUNTY DEPARTMENT: Palm Beach County Water Utilities

Section A PLEASE LIST THE DOLLAR AMOUNT OR PERCENTAGE OF WORK TO BE COMPLETED BY THE PRIME CONTRACTOR/CONSULTANT* ON THE PROJECT:

NAME OF PRIME RESPONDENT/BIDDER: CDM Constructors Inc. ADDRESS: 621 N.W 53rd Street, Suit 285, Boca Raton, FL 33487

CONTACT PERSON: Tommy L. Floyd, Senior Vice President PHONE NO.: 423-791-4880 E-MAIL: Floydtl@cdmsmith.com

PRIME'S DOLLAR AMOUNT OR PERCENTAGE OF WORK: \$2,247,443.48
 SBE Prime's must include their percentage or dollar amount in the Total Participation line under section B.

Non-SBE SBE

Section B PLEASE LIST THE DOLLAR AMOUNT OR PERCENTAGE OF WORK TO BE COMPLETED BY ALL SUBCONTRACTORS/SUBCONSULTANTS ON THE PROJECT BELOW:

Subcontractor/Sub consultant Name	(Check all Applicable Categories)		DOLLAR AMOUNT OR PERCENTAGE OF WORK
	Non-SBE	SBE	
1. A CUT ABOVE LANDSCAPE AND MAINTENANCE, INC.	<input type="checkbox"/>	<input checked="" type="checkbox"/>	\$22,395.00
2. Advanced Painting Contractors, Inc.	<input checked="" type="checkbox"/>	<input type="checkbox"/>	\$11,860.00
3. GRAYBAR ELECTRIC COMPANY, INC.	<input checked="" type="checkbox"/>	<input type="checkbox"/>	\$216,925.00
4. H AND J CONTRACTING, INC.	<input checked="" type="checkbox"/>	<input type="checkbox"/>	\$1,143,900.00
5. Rep Services	<input checked="" type="checkbox"/>	<input type="checkbox"/>	\$17,725.32

(Please use additional sheets if necessary)

Total Bid/Offer Price \$ \$4,997,748.80

Total _____

Total Certified SBE Participation \$ _____

I hereby certify that the above information is accurate to the best of my knowledge: Tommy L. Floyd

Name & Authorized Signature

Senior Vice President
Title

- Note:**
- The amount listed on this form for a Subcontractor/sub consultant must be supported by price or percentage listed on the properly executed Schedule 2 or attached signed proposal.
 - Only those firms certified by Palm Beach County at the time of solicitation due date are eligible to meet the established OSBD Affirmative Procurement Initiative (API). Please
 - Modification of this form is not permitted and will be rejected upon submittal.
 - If a Mandatory API goal applies, failure to submit a properly executed Schedule 2 will result in a determination of non-responsiveness to the solicitation.

OSBD SCHEDULE 1

SOLICITATION/PROJECT/BID NAME: Green Cay Phase 2 Progressive Design-Build

SOLICITATION/PROJECT/BID NO.: WUD Project No. 20-036

SOLICITATION OPENING/SUBMITTAL DATE: December 17, 2020

COUNTY DEPARTMENT: Palm Beach County Water Utilities

Section A PLEASE LIST THE DOLLAR AMOUNT OR PERCENTAGE OF WORK TO BE COMPLETED BY THE PRIME CONTRACTOR/CONSULTANT* ON THE PROJECT:

NAME OF PRIME RESPONDENT/BIDDER: CDM Constructors Inc. ADDRESS: 621 N.W 53rd Street, Suit 285, Boca Raton, FL 33487

CONTACT PERSON: Tommy L. Floyd, Senior Vice President PHONE NO.: 423-791-4880 E-MAIL: Floydtl@cdmsmith.com

PRIME'S DOLLAR AMOUNT OR PERCENTAGE OF WORK: \$2,247,443.48

SBE Prime's must include their percentage or dollar amount in the Total Participation line under section B.

Non-SBE SBE

Section B PLEASE LIST THE DOLLAR AMOUNT OR PERCENTAGE OF WORK TO BE COMPLETED BY ALL SUBCONTRACTORS/SUBCONSULTANTS ON THE PROJECT BELOW:

Subcontractor/Sub consultant Name	(Check all Applicable Categories)		DOLLAR AMOUNT OR PERCENTAGE OF WORK
	Non-SBE	SBE	
1. Florida Design Drilling LLC	<input checked="" type="checkbox"/>	<input type="checkbox"/>	\$1,337,500.00
2.	<input type="checkbox"/>	<input type="checkbox"/>	_____
3.	<input type="checkbox"/>	<input type="checkbox"/>	_____
4.	<input type="checkbox"/>	<input type="checkbox"/>	_____
5.	<input type="checkbox"/>	<input type="checkbox"/>	_____

(Please use additional sheets if necessary)

Total Bid/Offer Price \$ \$4,997,748.80

Total \$2,727,910.32

Total Certified SBE Participation \$ \$22,395.00

I hereby certify that the above information is accurate to the best of my knowledge: Tommy L. Floyd  Senior Vice President

Name & Authorized Signature

Title

- Note:**
- The amount listed on this form for a Subcontractor/sub consultant must be supported by price or percentage listed on the properly executed Schedule 2 or attached signed proposal.
 - Only those firms certified by Palm Beach County at the time of solicitation due date are eligible to meet the established OSBD Affirmative Procurement Initiative (API). Please
 - Modification of this form is not permitted and will be rejected upon submittal.
 - If a Mandatory API goal applies, failure to submit a properly executed Schedule 2 will result in a determination of non-responsiveness to the solicitation.

ATTACHMENT C
OSBD SCHEDULE 2

OFFICE OF SMALL BUSINESS DEVELOPMENT COMPLIANCE PROGRAMS

REVISED 07-08-25

OSBD LETTER OF INTENT – SCHEDULE 2*

A completed Schedule 2 is a binding document between the Prime Contractor/consultant and a Subcontractor/subconsultant (for any tier) and should be treated as such. All Subcontractors/subconsultants, including any tiered Subcontractors/subconsultants, must properly execute this document. If a Mandatory API goal applies, failure to submit a properly executed Schedule 2 will result in a determination of non-responsiveness to the solicitation. Each properly executed Schedule 2 must be submitted with the bid/proposal.

SOLICITATION/PROJECT NUMBER: PBCWUD Project No. 20-036

SOLICITATION/PROJECT NAME: Green Cay Phase 2 Progressive Design-Build

Prime Contractor: CDM Constructors Inc. Subcontractor: A CUT ABOVE LANDSCAPE AND MAINTENANCE, INC.

(Check box(s) that apply)

SBE Non-SBE Supplier

Date of Palm Beach County Certification (if applicable): 7/8/23-7/7/26

SBE PARTICIPATION – SBE Primes must document all work to be performed by their own work force on this form. Specify in detail, the scope of work to be performed or items supplied with the dollar amount and/or percentage for each work item. When applicable, identify the line item(s) associated with the service/product being supplied. SBE credit will only be given for the areas in which the SBE is certified. A detailed quote/proposal may be attached to a properly executed Schedule 2 for additional information.

Line Item	Item Description	Unit Price	Quantity/ Units	Contingencies/ Allowances	Total Price/Percentage
1	Add WPF Irrigation Upgrades	\$22,395.00	1		\$22,395.00

The undersigned Subcontractor/subconsultant is prepared to self-perform the above-described work in conjunction with the aforementioned project at the following total price or percentage: \$22,395.00

If the undersigned intends to subcontract any portion of this work to another Subcontractor/subconsultant, please list the business name and the amount below accompanied by a separate properly executed Schedule 2.

Name of 2nd/3rd tier Subcontractor/subconsultant _____ Price or Percentage: _____

CDM Constructors Inc.

Print Name of Prime

By: [Signature]
Authorized Signature

Tommy L. Floyd

Print Name

Senior Vice President

Title

Date: 04.02.2026

A CUT ABOVE LANDSCAPE AND MAINTENANCE, INC.

Print Name of Subcontractor/subconsultant

By: [Signature]
Authorized Signature

Damon Rudolph

Print Name

President

Title

Date: 3/31/26

* Revised 6.5.2025 pursuant to Emergency Ordinance 2025-016, approved on June 3, 2025

OSBD LETTER OF INTENT – SCHEDULE 2*

A completed Schedule 2 is a binding document between the Prime Contractor/consultant and a Subcontractor/subconsultant (for any tier) and should be treated as such. All Subcontractors/subconsultants, including any tiered Subcontractors/subconsultants, must properly execute this document. If a Mandatory API goal applies, failure to submit a properly executed Schedule 2 will result in a determination of non-responsiveness to the solicitation. Each properly executed Schedule 2 must be submitted with the bid/proposal.

SOLICITATION/PROJECT NUMBER: PBCWUD Project No. 20-036
 SOLICITATION/PROJECT NAME: Green Cay Phase 2 Progressive Design-Build

Prime Contractor: CDM Constructors Inc. Subcontractor: Advanced Painting Contractors, Inc.
(Check box(s) that apply)

SBE Non-SBE Supplier Date of Palm Beach County Certification (if applicable): _____

SBE PARTICIPATION – SBE Primes must document all work to be performed by their own work force on this form. Specify in detail, the scope of work to be performed or items supplied with the dollar amount and/or percentage for each work item. When applicable, identify the line item(s) associated with the service/product being supplied. SBE credit will only be given for the areas in which the SBE is certified. A detailed quote/proposal may be attached to a properly executed Schedule 2 for additional information.

Line Item	Item Description	Unit Price	Quantity/ Units	Contingencies/ Allowances	Total Price/Percentage
1	Add Tnemec	\$11,860.0	1		\$11,860.00

The undersigned Subcontractor/subconsultant is prepared to self-perform the above-described work in conjunction with the aforementioned project at the following total price or percentage: \$11,860.00

If the undersigned intends to subcontract any portion of this work to another Subcontractor/subconsultant, please list the business name and the amount below accompanied by a separate properly executed Schedule 2.

Name of 2nd/3rd tier Subcontractor/subconsultant _____ Price or Percentage: _____

CDM Constructors Inc.
 Print Name of Prime
 By: 
 Authorized Signature
Tommy L. Floyd
 Print Name
Senior Vice President
 Title
 Date: 04.02.2026

Advanced Painting Contractors, Inc.
 Print Name of Subcontractor/subconsultant
 By: 
 Authorized Signature
James Beckmon
 Print Name
Vice President
 Title
 Date: 04/01/2026

OSBD LETTER OF INTENT -- SCHEDULE 2*

A completed Schedule 2 is a binding document between the Prime Contractor/consultant and a Subcontractor/subconsultant (for any tier) and should be treated as such. All Subcontractors/subconsultants, including any tiered Subcontractors/subconsultants, must properly execute this document. If a Mandatory API goal applies, failure to submit a properly executed Schedule 2 will result in a determination of non-responsiveness in the solicitation. Each properly executed Schedule 2 must be submitted with the bid/proposal.

SOLICITATION/PROJECT NUMBER: PBCWUD Project No. 20-036

SOLICITATION/PROJECT NAME: Green Cay Phase 2 Progressive Design-Build

Prime Contractor: CDM Constructors Inc. Subcontractor: GRAYBAR ELECTRIC COMPANY, INC.

(Check box(s) that apply)

SBE Non-SBE Supplier Date of Palm Beach County Certification (if applicable): _____

SBE PARTICIPATION - SBE Primes must document all work to be performed by their own work force on this form. Specify in detail, the scope of work to be performed or items supplied with the dollar amount and/or percentage for each work item. When applicable, identify the line item(s) associated with the service/product being supplied. SBE credit will only be given for the areas in which the SBE is certified. A detailed proposal may be attached to a properly executed Schedule 2 for additional information.

Line Item	Item Description	Unit Price	Quantity/ Units	Contingencies/ Allowances	Total Price/Percentage
1	015 Controls Equipment Materials Only	\$216,925.00	1		\$216,925.00

The undersigned Subcontractor/subconsultant is prepared to self-perform the above described work in conjunction with the aforementioned project at the following total price or percentage: **\$216,925.00**

If the undersigned intends to subcontract any portion of this work to another Subcontractor/subconsultant, please list the business name and the amount below accompanied by a separate properly executed Schedule 2.

Name of 2nd/3rd tier Subcontractor/subconsultant _____ Price or Percentage _____

CDM Constructors Inc.

Print Name of Prime
By:  Authorized Signature

Tommy L. Floyd

Print Name
Senior Vice President

Date
04.02.2026

GRAYBAR ELECTRIC COMPANY, INC.

Print Name of **Vendor**
By:  Authorized Signature

Amon J. Guerrero

Print Name
Branch Manager

Date
4/1/2026

****Graybar Electric Company, Inc. is a material distributor only and does not perform labor, installation, or subcontractor services. Any subcontractor-specific terms do not apply.****

*Revised 6.3.2025 pursuant to Emergency Ordinance 2025-014, approved on June 3, 2025

OSBD LETTER OF INTENT – SCHEDULE 2*

A completed Schedule 2 is a binding document between the Prime Contractor/consultant and a Subcontractor/subconsultant (for any tier) and should be treated as such. All Subcontractors/subconsultants, including any tiered Subcontractors/subconsultants, must properly execute this document. If a Mandatory API goal applies, failure to submit a properly executed Schedule 2 will result in a determination of non-responsiveness to the solicitation. Each properly executed Schedule 2 must be submitted with the bid/proposal.

SOLICITATION/PROJECT NUMBER: PBCWUD Project No. 20-036
 SOLICITATION/PROJECT NAME: Green Cay Phase 2 Progressive Design-Build

Prime Contractor: CDM Constructors Inc. Subcontractor: H AND J CONTRACTING, INC.
 (Check box(s) that apply)

SBE Non-SBE Supplier Date of Palm Beach County Certification (if applicable): _____

SBE PARTICIPATION – SBE Primes must document all work to be performed by their own work force on this form. Specify in detail, the scope of work to be performed or items supplied with the dollar amount and/or percentage for each work item. When applicable, identify the line item(s) associated with the service/product being supplied. SBE credit will only be given for the areas in which the SBE is certified. A detailed quote/proposal may be attached to a properly executed Schedule 2 for additional information.

Line Item	Item Description	Unit Price	Quantity/ Units	Contingendes/ Allowances	Total Price/Percentage
1	070 Prepare Well Pads & Furnish & Install HDD & Hard Piping	\$1,143,900.00	1		\$1,143,900.00

The undersigned Subcontractor/subconsultant is prepared to self-perform the above-described work in conjunction with the aforementioned project at the following total price or percentage: \$1,143,900.00

If the undersigned intends to subcontract any portion of this work to another Subcontractor/subconsultant, please list the business name and the amount below accompanied by a separate properly executed Schedule 2.

_____ Price or Percentage: _____
 Name of 2nd/3rd tier Subcontractor/subconsultant

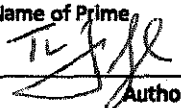
CDM Constructors Inc.
 Print Name of Prime
 By: 
 Authorized Signature
Tommy L. Floyd
 Print Name
Senior Vice President
 Title
 Date: 04.02.2026

H AND J CONTRACTING, INC.
 Print Name of Subcontractor/subconsultant
 By: Joe Whitten
 Authorized Signature
Digitally signed by Joe Whitten
 DN: C=US, E=jow@hcontracting.com, O=H&J Contracting, Inc., CN=Joe Whitten
 Date: 2026.04.01 16:52:40 -0400

 Print Name

 Title

 Date: _____

OSBD LETTER OF INTENT – SCHEDULE 2*

A completed Schedule 2 is a binding document between the Prime Contractor/consultant and a Subcontractor/subconsultant (for any tier) and should be treated as such. All Subcontractors/subconsultants, including any tiered Subcontractors/subconsultants, must properly execute this document. If a Mandatory API goal applies, failure to submit a properly executed Schedule 2 will result in a determination of non-responsiveness to the solicitation. Each properly executed Schedule 2 must be submitted with the bid/proposal.

SOLICITATION/PROJECT NUMBER: PBCWUD Project No. 20-036
 SOLICITATION/PROJECT NAME: Green Cay Phase 2 Progressive Design-Build

Prime Contractor: CDM Constructors Inc. Subcontractor: Rep Services, Inc.
 (Check box(s) that apply)

SBE Non-SBE Supplier Date of Palm Beach County Certification (if applicable): _____

SBE PARTICIPATION – SBE Primes must document all work to be performed by their own work force on this form. Specify in detail, the scope of work to be performed or items supplied with the dollar amount and/or percentage for each work item. When applicable, identify the line item(s) associated with the service/product being supplied. SBE credit will only be given for the areas in which the SBE is certified. A detailed quote/proposal may be attached to a properly executed Schedule 2 for additional information.

Line Item	Item Description	Unit Price	Quantity/Units	Contingendes/Allowances	Total Price/Percentage
1	Balance of Picnic Tables, Benches & Concrete Pad	\$17,725.32	1		\$17,725.32

The undersigned Subcontractor/subconsultant is prepared to self-perform the above-described work in conjunction with the aforementioned project at the following total price or percentage: \$17,725.32

If the undersigned intends to subcontract any portion of this work to another Subcontractor/subconsultant, please list the business name and the amount below accompanied by a separate properly executed Schedule 2.

Name of 2nd/3rd tier Subcontractor/subconsultant _____ Price or Percentage: _____

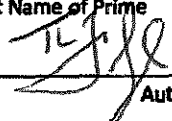
CDM Constructors Inc.
 Print Name of Prime
 By: 
 Authorized Signature
Tommy L. Floyd
 Print Name
Senior Vice President
 Title
 Date: 04.02.2026

Rep Services, Inc.
 Print Name of Subcontractor/subconsultant
 By: 
 Authorized Signature
Dennis Roberts
 Print Name
Vice President
 Title
 Date: 04/01/26

*Revised 6.5.2025 pursuant to Emergency Ordinance 2025-01A, approved on June 3, 2025

OSBD LETTER OF INTENT – SCHEDULE 2*

A completed Schedule 2 is a binding document between the Prime Contractor/consultant and a Subcontractor/subconsultant (for any tier) and should be treated as such. All Subcontractors/subconsultants, including any tiered Subcontractors/subconsultants, must properly execute this document. If a Mandatory API goal applies, failure to submit a properly executed Schedule 2 will result in a determination of non-responsiveness to the solicitation. Each properly executed Schedule 2 must be submitted with the bid/proposal.

SOLICITATION/PROJECT NUMBER: PBCWUD Project No. 20-036

SOLICITATION/PROJECT NAME: Green Cay Phase 2 Progressive Design-Build

Prime Contractor: CDM Constructors Inc. Subcontractor: Florida Design Drilling LLC

(Check box(s) that apply)

SBE Non-SBE Supplier

Date of Palm Beach County Certification (if applicable): _____

SBE PARTICIPATION – SBE Primes must document all work to be performed by their own work force on this form. Specify in detail, the scope of work to be performed or items supplied with the dollar amount and/or percentage for each work item. When applicable, identify the line item(s) associated with the service/product being supplied. SBE credit will only be given for the areas in which the SBE is certified. A detailed quote/proposal may be attached to a properly executed Schedule 2 for additional information.

Line Item	Item Description	Unit Price	Quantity/ Units	Contingencies/ Allowances	Total Price/Percentage
1	Additional Production Wells	\$1,337,500.00	1		\$1,337,500.00

The undersigned Subcontractor/subconsultant is prepared to self-perform the above-described work in conjunction with the aforementioned project at the following total price or percentage: \$1,337,500.00

If the undersigned intends to subcontract any portion of this work to another Subcontractor/subconsultant, please list the business name and the amount below accompanied by a separate properly executed Schedule 2.

_____ Price or Percentage: _____

Name of 2nd/3rd tier Subcontractor/subconsultant

CDM Constructors Inc.

Print Name of Prime

By: 
Authorized Signature

Tommy L. Floyd

Print Name

Senior Vice President

Title

Date: 04.02.2026

Florida Design Drilling LLC

Print Name of Subcontractor/subconsultant

By: Brandon Holst Digitally signed by Brandon Holst
Date: 2026.04.01 08:09:41 -04'00'
Authorized Signature

Brandon Holst

Print Name

Vice President

Title

Date: 4/1/26

ATTACHMENT D

LOCATION MAP

PBCWUD Project No. 20-036

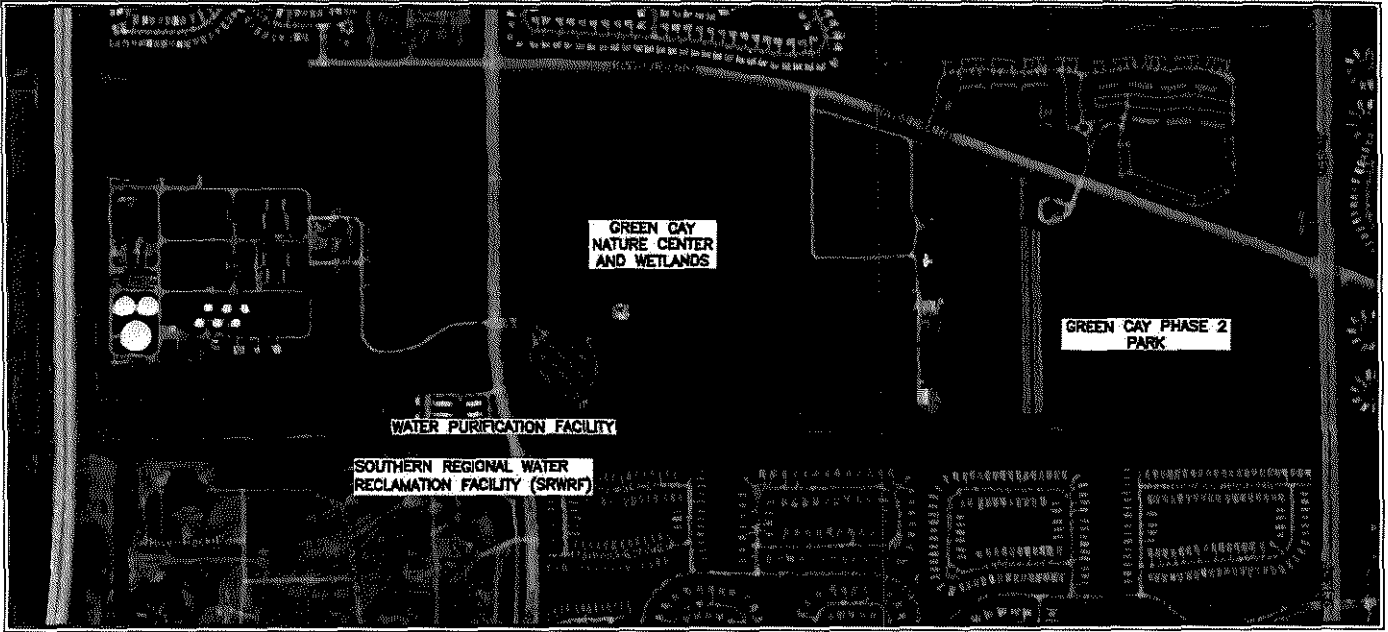

REVISED 07-08-25

ATTACHMENT E

BOND RIDER (NOT APPLICABLE)

No bond rider is required with Change Order 4 due to the deductive change orders, the original bond is adequate to cover Change Order 4.

REVISED 07-08-25

ATTACHMENT F

SUPPORTING DOCUMENTATION

REVISED 07-08-25



ATTACHMENT F

INDEX

PCO 008 – Add'l Production Wells (3W-34) & (3W-36)	SUBTOTAL	\$	4,938,170.64
Indirect Costs - Insurance, Bonds, OH&P (see PCO-008 for breakout)		\$	635,903.00
General Conditions		\$	141,880.00
Construction Allowances (see PCO-008 for breakout)		\$	103,005.90
CDM Engineering		\$	250,275.00
FPL Allowance		\$	250,000.00
005 Well Drilling, Casing, Grout, Pump, Disinfect, Test, Dev.		\$	1,337,500.00
010 I&C Conduits & Wiring Install Only		\$	293,640.09
015 Controls Equipment Materials Only		\$	216,925.00
050 RTU w/Related, Control Panel UPS, & Antenna		\$	330,269.65
070 Prepare Well Pads & Furnish & Install HDD & Hard Piping		\$	1,143,900.00
060-090 Mechanical		\$	234,872.00
PCO 009 – Chemical Canopy - Tnemec Paint	SUBTOTAL	\$	13,164.60
Design-Builder OH&P (+11%)		\$	1,304.60
Add Tnemec		\$	11,860.00
PCO 010 – Balance of Park Picnic Tables	SUBTOTAL	\$	19,675.11
Design-Builder OH&P (+11%)		\$	1,949.79
Balance of Picnic Tables, Benches & Concrete Pad		\$	17,725.32
PCO 011 – WPF Irrigation Upgrades	SUBTOTAL	\$	26,738.45
Design-Builder OH&P (+11%)		\$	2,463.45
ESDC for Landscape EOR (no markups applied to this line.)		\$	1,880.00
Add WPF Irrigation Upgrades		\$	22,395.00
	TOTAL	\$	4,997,748.80



■ PCO 008

Additional Production Wells 3W-34 & 3W-36

PCO 008 – Add'l Production Wells (3W-34) & (3W-36)	SUBTOTAL	\$	4,938,170.64
Indirect Costs - Insurance, Bonds, OH&P (see PCO-008 for breakout)		\$	635,903.00
General Conditions		\$	141,880.00
Construction Allowances (see PCO-008 for breakout)		\$	103,005.90
CDM Engineering		\$	250,275.00
FPL Allowance		\$	250,000.00
005 Well Drilling, Casing, Grout, Pump, Disinfect, Test, Dev.		\$	1,337,500.00
010 I&C Conduits & Wiring Install Only		\$	293,640.09
015 Controls Equipment Materials Only		\$	216,925.00
050 RTU w/Related, Control Panel UPS, & Antenna		\$	330,269.65
070 Prepare Well Pads & Furnish & Install HDD & Hard Piping		\$	1,143,900.00
060-090 Mechanical		\$	234,872.00



Date: 04/07/26

Green Cay Phase II, ADD Production Wells 3W-34 & 3W-36 - Open Cut

Labor/Materials/Equipment/Subcontract/Other		
FL Drilling	005 Well Drilling, Casing, Grout, Pump, Disinfect, Test, Dev.	\$ 1,337,500.00
CCI-E Electrical	010 I&C Conduits & Wiring Install Only	\$ 293,640.09
Graybar	015 Controls Equipment Materials Only	\$ 216,925.00
Allowance	020 Concrete Pads	\$ 14,898.90
Allowance	030 Layout & Locate Pads	\$ 20,000.00
Allowance	035 Test Testing & Inspections Allowance - (Densities, Concrete	\$ 20,000.00
Allowance	040 Production Well Process Painting Allowance	\$ 4,081.00
Allowance	045 Fences & Gates Allowance	\$ 44,026.00
CCI-E Automation	050 RTU w/Related, Control Panel UPS, & Antenna	\$ 330,269.65
CCI-M	060-090 Mechanical	\$ 234,872.00
H & J Contracting, Inc.	070 Prepare Well Pads & Furnish & Install HDD & Hard Piping	\$ 1,143,900.00
Indirect Costs - Insurance, Bonds, OH&P		
	Construction Contingency	\$ 170,000.00
	Indirect Costs - Insurance & Bonds	\$ 40,172.00
	Design-Builder OH&P (+11%)	\$ 425,731.00
General Conditions		
	General Conditions	\$ 141,880.00
CDM Engineering		
	ESDC - CDM Engineering	\$ 250,275.00
Allowances		
	FP&L	\$ 250,000.00
TOTAL		\$ 4,938,170.64



101 Southhall Lane Suite 200
Maitland, FL 32751
tel: 407-660-2552

April 09, 2026

Ms. Jie "Jane" House, P.E., LEED AP
Director of Engineering
Palm Beach County Water Utilities Department (PBCWUD)

Subject: Green Cay Phase 2 Progressive DB Project
RE: Potential Change Order No. 008 – Additional Production North Wells 3W-34 & 3W-36

Dear Ms. House:

CDM Constructors Inc. (Design-Builder) has received the Palm Beach County Water Utilities Department (PBCWUD) request for the additional production North Wells 3W-34 and 3W-36. In coordination with several subcontractors and vendors, the Design-Builder has evaluated the request for associated cost and schedule impacts.

This proposal includes administrative costs, general conditions, and allowances for fencing, gates, testing, inspections, surveying, design, construction, and ESDCs. However, this proposal does not include the costs and time for FPL's scope of work and will be billed at actual costs at PBCWUD's expense.

For PCO 008, Additional Production Wells (3W-34) and (3W-36), the Design-Build Entity shall commence work within ten (10) calendar days of issuance of the Notice to Proceed (NTP). From the date of NTP issuance, Substantial Completion shall be achieved within 300 calendar days, and Final Construction Completion shall be achieved within 330 calendar days. Liquidated damages for PCO 008 shall apply at a rate of \$500.00 per day for each day beyond the Substantial Completion date and \$250.00 per day for each day beyond the Final Completion date.

Should PBCWUD wish to proceed, please review and issue an Amendment to increase the Guaranteed Maximum Price (GMP) by \$4,938,170.64.

If you have any questions or concerns, please contact us.

Sincerely,

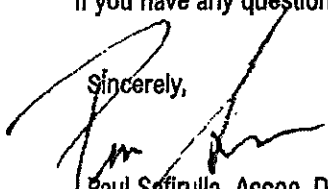
Paul Saifurulla, Assoc. DBIA,
Project Manager,
CDM Constructors Inc.

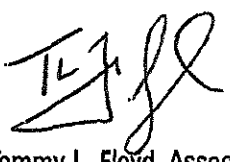
Tommy L. Floyd, Assoc. DBIA,
Senior Vice President,
CDM Constructors Inc.

cc: CDM Smith, Inc: Paul Saifurulla, Suzanne Mechler
Hazen and Sawyer: Richard Davis
Attached(s): PCO-008 Backup



101 Southhall Lane Suite 200
Maitland, FL 32751
tel: 407-660-2552

April 01, 2026

RISK BUDGET BREAKDOWN MEMO

The \$170,000 Construction Contingency was distributed across the identified risk items based on each item's potential maximum exposure. To keep the allocation generally even and practical, percentages of 31% and 32% were applied, which results in a total contingency allocation of **\$170,000**.

The risks we've identified:

- The concrete subcontractor Integ-crete has declined the work – we carried \$14,898 and are proceeding with this number as a budget.
 - o Potential **\$5,000 to \$10,000** Risk to procure another subcontractor.
- Drilling operations risk – may have to drill slightly deeper, or if more cement is needed to case the well – quantities below surface are much harder to gauge than above ground.
 - o Potential **\$25,000 to \$75,000** Risk in additional costs
- Well Driller/Subcontractors availability – potential time impact which increases GCs
 - o Potential **\$45,000 to \$120,000** Risk in additional time
- Design Progression – the pipe has not been modeled with 4 pumps only – potential change to materials.
 - o Potential **\$15,000 to \$85,000** Risk mainly H&J changing size of pipe.
- Schedule Impact due to Well Testing/Weather/Delay in Construction increases GCs
 - o Potential **\$35,000 to \$225,000** in additional GCs if extended beyond main contract.
- Increase in electrical and controls components – Graybar stated that they have already two price changes and if we take too long to start, he may not be able to hold his price.
 - o Potential **\$10,000 to \$25,000** to increase cost of materials.

Risk Item	Risk Value	Applied Percentage	Contingency Amount
Integ-crete replacement risk	\$10,000	32%	\$3,200
Drilling operations risk	\$75,000	31%	\$23,250
Well driller / subcontractor availability risk	\$120,000	31%	\$37,200
Design progression risk	\$85,000	31%	\$26,350
Schedule impact due to well testing / weather / delay in construction	\$225,000	32%	\$72,000
Electrical and controls material escalation risk	\$25,000	32%	\$8,000
Total	\$540,000		\$170,000

Palm Beach County, FL
Additional Production Wells 3W39 & 3W40, PCO
Opinion of Probable Construction Cost, April 2026, PCO

Estimator	Elias Andraos
Labor rate table	FL26 W Palm Beach
Equipment rate table	2026H1 \$4Equip BF
ENR CCI	SEP 2025: 13,927.75
AACEi Class	1
Estimate Type	Design Build
Design Level	90%

Notes

This is an Opinion of Probable Construction Cost only, as defined by the documents provided at the level of design indicated above. CDM Smith has no control over the cost of labor, materials, equipment, or services furnished, over schedules, over contractor's methods of determining prices, competitive bidding (at least 3 each - both prime bidders and major subcontractors), market conditions or negotiating terms. CDM Smith does not guarantee that this opinion will not vary from actual cost, or contractor's bids.

There are not any costs provided for: Change Orders, Design Engineering, Construction Oversight, Client Costs, Finance or Funding Costs, Legal Fees, Land Acquisition or temporary/permanent Easements, Operations, or any other costs associated with this project that are not specifically part of the bidding contractor's proposed scope. This OPCC shall remain valid for 30 days. Beyond this date, CDM Constructors should be notified of design changes. The estimate will also be reviewed to reflect current market conditions.

Assumptions:
 No money for COVID/Tariffs/Surcharges is included.
 No rock excavation is required.
 Only nominal dewatering is needed.
 No consideration for contaminated soils or hazardous materials is included (i.e. asbestos, lead, etc).
 Based on a normal 40 hour work week with no overtime.

Report format

Sorted by 'Package/Area'
 'Area' summary
 Allocate addons



Palm Beach County, FL
 Additional Production Wells 3W39 & 3W40, PCO
 (INDIRECT COSTS UNALLOCATED)

Spreadsheet Level	Takeoff Quantity	Labor Amount	Material Amount	Equip Amount	Sub Amount	Other Amount	Total Cost/Unit	Total Amount
1 Subcontractors								
005 Well Drilling Casing, Grout, Pump, Disinfect, Test, Dev.					1,337,500			1,337,500
010 I&C Conduits & Wiring - CCI					293,640			293,640
015 Controls Equipment					216,925			216,925
020 Concrete Pads					14,899			14,899
030 Layout & Locate Pads					20,000			20,000
035 EW Testing & Inspections Allowance - (Densities, Concrete Pads)					20,000			20,000
040 Production Well Process Painting Allowance					4,081			4,081
045 Fence & Gates Allowance					44,026			44,026
1 Subcontractors					1,951,071			1,951,071
2 CCI Electrical								
050 RTU w/Radios, Control Panel UPS, & Antenna					330,270			330,270
2 CCI Electrical					330,270			330,270
3 CCI Mechanical								
060 Furnish Production Well AG Valves	8.00 ea		48,350				6,043.75 /ea	48,350
065 Furnish Production Well AG DIP & Accessories	24.00 lf		29,608				1,233.66 /lf	29,608
080 Install Production Well Above Grade Piping	2.00 ea				109,444		54,722.00 /ea	109,444
085 Testing & Inspections Allowance	1.00 ls				23,735		23,735.00 /ls	23,735
090 Surveying Allowance	1.00 ls				23,735		23,735.00 /ls	23,735
3 CCI Mechanical			77,958		156,914			234,872
4 Prepare Well Pads & F&I HDD & Hard Piping								
070 Furnish & Install HDD & Hard Piping w/Restoration	2,220.00 lf				1,143,900		515.27 /lf	1,143,900
4 Prepare Well Pads & F&I HDD & Hard Piping					1,143,900			1,143,900

Estimate Totals

Description	Amount	Totals	Hours	Rate
Labor			140.840 hrs	
Material	77,958			
Equipment			7.896 hrs	
Subcontract	3,582,155			
Other				
	<u>3,660,113</u>	3,660,113		
Construction Contingency	170,000			
Subtotal	<u>170,000</u>	3,830,113		
Indirect Costs				
CCI Insurance (% total cost)	5,605			0.114 %
CCI Bonds (% total cost)	34,567			0.700 %
Subtotal	<u>40,172</u>	3,870,285		
Contractor Total OH&P	425,731			11.000 %
Subtotal	<u>425,731</u>	4,296,016		
General Conditions				
GC General Conditions	141,880			
Subtotal	<u>141,880</u>	4,437,896		
CDM Engineering				
Design	108,825			
ESDC	67,704			
RPR Field Hydro	73,746			
Subtotal	<u>250,275</u>	4,688,171		
Allowances				
FP&L	250,000			
Subtotal	<u>250,000</u>	4,938,171		
Total		4,938,171		

"This Opinion of Probable Construction Cost is produced in accordance with CDM Smith's Firmwide Quality policies and best practices as described in CDM Smith's Estimating Manual Dated 01/03/12 Section 10 titled Quality Control. I hereby acknowledge that the Cost Estimating policies and procedures were followed in preparation of the Opinion of Probable Cost".

Estimator initials - EA 4/7/2026



ELM REPORT

CLIENT NAME: Palm Beach County Utilities
 PROJECT NAME: Addl Wells

PROJECT MANAGER: Paul Safrulla
 PROJECT NUMBER: _____

Cost Item	Takeoff Quantity	Labor Manhours	Hours Per Week	Labor Rate	Labor Amount	Material Amount	Equip Amount	Sub Amount	Other Amount	Total Unit Cost	Total Amount
CONSTRUCTION GENERAL CONDITIONS STAFFING											
PROJECT MANAGEMENT STAFF											
Project Mgr	14.29 /wkw	228.57 mh	16.0	\$ 224.00 /hr	\$ 51,200	\$ -	\$ 3,848	\$ -	\$ -	\$ 3,852.33 /wkw	\$ 55,048
Assistant PM	14.29 /wkw	114.29 mh	8.0	\$ 164.00 /hr	\$ 18,743	\$ -	\$ 97	\$ -	\$ -	\$ 1,318.82 /wkw	\$ 18,840
Project Account	14.29 /wkw	14.29 mh	1.0	\$ 111.00 /hr	\$ 1,586	\$ -	\$ 12	\$ -	\$ -	\$ 111.85 /wkw	\$ 1,598
PROJECT MANAGEMENT STAFF	14.29 /wkw	357.14 mh			\$ 71,529	\$ -	\$ 3,957	\$ -	\$ -	\$ 5,284.00 /wkw	\$ 75,486
FIELD STAFF											
Construction Mgr	14.29 /wkw	28.57 mh	2.0	\$ 224.00 /hr	\$ 6,400	\$ -	\$ 481	\$ -	\$ -	\$ 481.67 /wkw	\$ 6,881
General Super	14.29 /wkw	114.29 mh	8.0	\$ 242.00 /hr	\$ 27,657	\$ -	\$ 1,924	\$ -	\$ -	\$ 2,070.67 /wkw	\$ 29,581
H&S Mgr	14.29 /wkw	57.14 mh	4.0	\$ 209.00 /hr	\$ 11,943	\$ -	\$ 962	\$ -	\$ -	\$ 903.33 /wkw	\$ 12,905
FIELD STAFF	14.29 /wkw	200.00 mh			\$ 46,000	\$ -	\$ 3,367	\$ -	\$ -	\$ 3,455.67 /wkw	\$ 49,367
CLERICAL STAFF											
Project Admin	14.29 /wkw	57.14 mh	4.0	\$ 96.00 /hr	\$ 5,486	\$ -	\$ 49	\$ -	\$ -	\$ 387.41 /wkw	\$ 5,534
CLERICAL STAFF	14.29 /wkw	57.14 mh			\$ 5,486	\$ -	\$ 49	\$ -	\$ -	\$ 387.41 /wkw	\$ 5,534
CONSTR EQUIP & SMALL TOOLS											
Misc Small Tools	557 /Mh					\$ 1,671				\$ 3.00 /Mh	\$ 1,671
CONSTR EQUIP & SMALL TOOLS						\$ 1,671					\$ 1,671
SAFETY											
Safety Supplies	557 /Mh					\$ 312			\$ 0.56 /Mh		\$ 312
SAFETY						\$ 312		\$ -			\$ 312
CONTRACT REQUIREMENTS											
Textura Accounting	1 /LS							\$ 3,300		\$ 3,300.00 /LS	\$ 3,300
Predictive Solutions	1 /LS							\$ 1,000		\$ 1,000.00 /LS	\$ 1,000
LCP Certified Payroll	1 /LS							\$ 700		\$ 699.50 /LS	\$ 700
CONTRACT REQUIREMENTS								\$ 5,000			\$ 5,000
Subtotal					\$ 123,014		\$ 9,356		\$ 5,000		\$ 137,370
Sales Tax	7.00%										\$ 489
Subtotal w/ Taxes											\$ 137,859
CCI G&A	7.60%										\$ 1,128
CCI FEE	3.40%										\$ 543
CONSTRUCTION GC's TOTAL											\$ 139,530
CONTRACT REQUIREMENTS											
Textura Accounting	1 /LS							\$ 275		\$ 275.00 /LS	\$ 275
Predictive Solutions	1 /LS							\$ 1,000		\$ 1,000.00 /LS	\$ 1,000
LCP Certified Payroll	1 /LS							\$ 700		\$ 699.50 /LS	\$ 700
CONTRACT REQUIREMENTS								\$ 1,975			\$ 1,975
Subtotal					\$ -		\$ -		\$ 1,975		\$ 1,975
Sales Tax	7.00%										\$ 138
Subtotal w/ Taxes											\$ 2,113
CCI G&A	7.60%										\$ 161
CCI FEE	3.40%										\$ 77
STARTUP & COMMISSIONING TOTAL											\$ 2,351
ELM COST REPORT (Precon/Preliminary Services + Construction GC's + Startup & Commissioning)											\$ 141,880

CDM ENGINEERING

WBS Name	Resource Type	Resource Name	Price
Design	Labor - Employee	Mechler, Suzanne E	\$ 1,223
Design	Labor - Employee	Pujals, Victor J	\$ 0
Design	Labor - Employee	O'Neil, Timothy J	\$ 9,886
Design	Labor - Employee	Anandam, Srinivasakuma	\$ 2,306
Design	Labor - Employee	Magenheimer, Stewart J	\$ 8,922
Design	Labor - Employee	Valdes, Jorge D	\$ 4,929
Design	Labor - Employee	Edwards, Anthony F	\$ 2,419
Design	Labor - Employee	Andersen, Glen R	\$ 0
Design	Labor - Employee	Gonzalez Moya, Daniel E	\$ 941
Design	Labor - Employee	Holowell, Isaac D	\$ 14,066
Design	Labor - Employee	Frizzell, Carl S	\$ 11,873
Design	Labor - Job	US-Environmental Engine	\$ 7,969
Design	Labor - Job	US-Environmental Engine	\$ 12,449
Design	Risk		
Design	ODC		\$ 10,332
Design	ODC		\$ 21,510
ESDC	Labor - Employee	Fonnegra, Sebastian	\$ 17,135
ESDC	Labor - Employee	Wiseman, Lee	\$ 0
ESDC	Labor - Employee	Mills, Jason M	\$ 0
ESDC	Labor - Employee	Anandam, Srinivasakuma	\$ 20,758
ESDC	Labor - Employee	Magenheimer, Stewart J	\$ 2,974
ESDC	Labor - Employee	Valdes, Jorge D	\$ 26,836
RPR Field Hydro	Labor - Employee	Palomo, Leah	\$ 73,746

TOTAL \$250,275.00

TABLE OF CONTENT

for WELLS 3W-34 & 3W-36

1 Subcontractors Backup

- ▣ 005 Well Drilling Casing, Grout, Pump, Disinfect, Test, Dev.
- ▣ 010 I&C Conduits & Wiring Install Only
- ▣ 015 Controls Equipment
- ▣ 020 Concrete Pads
- ▣ 070 Furnish & Install HDD & Hard Piping w/Restoration

2 CCI Electrical Backup

- ▣ 050 RTU w/Radios, Control Panel UPS, & Antenna

3 Clarification & Exceptions

4 Schedule

1 Subcontractors Backup

- **005 Well Drilling Casing, Grout, Pump, Disinfect, Test, Dev.**
 - **010 I&C Conduits & Wiring Install Only**
 - **015 Controls Equipment**
 - **070 Prepare Well Pads & Furnish & Install HDD & Hard Piping w/Restoration**
-

Florida Drilling

▪ 005 Well Drilling Casing, Grout, Pump, Disinfect, Test, Dev.

Exhibit A

Attachment 2 - Subcontract Price

SUBCONTRACTOR shall perform the Subcontract Work pursuant to the Subcontract Documents for the lump sum price ("Subcontract Price") as stated below

ITEM NO.	DESCRIPTION	QTY	UNITS	DIRECT HOURS	SUBTIER HOURS	LABOR \$	MATERIAL \$	EQUIPMENT \$	SUBTIER \$	TOTAL COST
INDIRECT COSTS										
	Mobilization	1	EA	106	11	\$ 50,208.89	\$ 26,128.93	\$ 22,182.18	\$ 16,500.00	\$ 95,000.00
	Demobilization	1	EA	106	0	\$ 15,578.46	\$ 1,340.63	\$ 8,082.92		\$ 25,000.00
	Temporary Facilities	1	LS	8	0	\$ 6,230.58	\$ 536.25	\$ 3,233.17		\$ 10,000.00
	Engineering & Shop Drawings	1	LS	8	0	\$ 3,115.29	\$ 268.13	\$ 3,866.58		\$ 7,250.00
	Permits	1	LS	8	0	\$ 3,115.29	\$ 288.13	\$ 3,866.58		\$ 7,250.00
	Sales & Use Taxes	1	LS	N/A	N/A	N/A	N/A	N/A	N/A	N/A
	Insurance & Bonds	1	LS	8	0	\$ 3,115.29	\$ 58,975.10	\$ 2,909.61		\$ 65,000.00
	SUBTOTAL INDIRECT COSTS			244	11	\$ 61,361.81	\$ 87,517.16	\$ 65,299.13	\$ 24,420.00	\$ 208,500.00
DIRECT COSTS										
	Well Drilling	2	EA	454		\$ 96,574.05	\$ 45,084.39	\$ 68,341.57		\$ 210,000.00
	Well Casing	2	EA	44		\$ 12,461.17	\$ 102,132.22	\$ 10,406.61		\$ 125,000.00
	Well Grout	2	EA	44		\$ 12,461.17	\$ 30,285.82	\$ 7,253.01		\$ 50,000.00
	Well Grout	2	EA	8		\$ 3,115.29	\$ 18,362.30	\$ 1,522.41		\$ 23,000.00
	Well Pump	2	EA	22		\$ 8,230.58	\$ 174,403.30	\$ 4,388.12		\$ 188,000.00
	Well Piping, Valves, & Appurtenances	2	EA	22		\$ 6,230.58	\$ 183,502.50	\$ 5,266.92		\$ 195,000.00
	Disinfection, Testing, & Development	2	EA	726	24	\$ 174,456.34	\$ 25,002.73	\$ 118,540.82	\$ 22,000.00	\$ 340,000.00
	MISCELLANEOUS COST (To Be Defined)									
	SUBTOTAL DIRECT COSTS			1320	24	\$ 311,529.19	\$ 578,773.26	\$ 215,587.56	\$ 22,000.00	\$ 1,128,000.00
	GRAND TOTAL			1564	35	\$ 372,891.00	\$ 666,290.41	\$ 280,996.69	\$ 46,420.00	\$ 1,397,500.00
	GRANT TOTAL Escalation 60 DAYS									
	GRANT TOTAL Escalation 90 DAYS									
	GRANT TOTAL Escalation 120 DAYS									

Quantities provided herein are for bid evaluation purposes only. The Subcontractor will be responsible to complete the scope or Work for the Subcontract Price regardless of quantities stated herein

TOTAL SUBCONTRACT PRICE

In Words: One Million Three Hundred Thirty-Seven Thousand Five Hundred Dollars and Zero Cents

In Figures: \$1,397,500

SUBMITTAL LEAD TIME:

In Weeks: 1 week

EQUIPMENT FABRICATION AND DELIVERY LEAD TIME (if applicable):

In Weeks: 28-30 weeks for pumps



12400 Coit Road, Suite 400
Dallas, TX - 75251
Phone: (214) 346-2800
Fax: (214) 987-2017

CHANGE ORDER

Customer Name: Paul Safirulla
Business Name: CDM CCI Constructors
Email: safirullapa@cdmsmith.com

December 5, 2025
Change Order #: 004
Project #: 265964

Subject: Future Wells 3W-34 & 3W-36

Dear Mr. Safirulla,

CDM Constructors Inc. (CCI) Automation and Electrical, a division of CDM Smith, presents this proposed cost change order related to supply and installs conduits, wire and ancillaries to provide power to wells 3W-34 and 3W-36 per the drawings attached as this was not included in the original bid package. The change order price is based on the inclusions/exclusions below:

Inclusions

1. Provide and install power conduits and wire for 2-75HP pumps up to 100lf per drawings attached.
2. Provide and install 3ea ¾" PVC Sch.80 conduits with #16 twisted shielded cables from the instruments to the local panel maximum of 100ft per well. One conduit for the ORP, one for the level transmitter and another conduit for the flow meter. This is assuming that RTU and other controls are in the pump control panel.
3. Supply and install sunshield and hardware to install the transmitters for level and flow. Instruments supplied and installed by others.

Exclusions

1. Well pumps, equipment, panels, instruments and programming provided by others.
2. Any repairs or modifications including programming to the existing PLC, Equipment controls, pumps, pipe, walls or slab.
3. Tapping to existing pipe or process piping and valves installation to the instruments.
4. Grouting for all equipment/instrument stands.
5. Providing concrete or concrete repairs for any panel or structures are not included.





12400 Coit Road, Suite 400
Dallas, TX - 75251
Phone: (214) 346-2800
Fax: (214) 987-2017

CHANGE ORDER

Installation Material and Labor Cost: \$244,700.08

Fee: \$48,940.02

Total Cost: \$293,640.09

Two Hundred Ninety-Three Thousand, Six Hundred Forty Dollars and Nine Cents.

Regards,

Richard E Charest

Digitally signed by Richard E Charest
DN: c=US,
E=rcharest2@cdmsmith.com, O=CCI,
OU=CCI, CN=Richard E Charest
Date: 2025.12.05 11:53:29-0500

CDM Smith

Richard Charest

12400 Coit Road, Suite 400

Dallas, TX 75251

(202) 570-9755

Green Cay Phase 2 CCI Electrical						
Injection Wells PIT	Qty	Labor	Rate	Subtotal	Taxes	Total
Project Manager		120.00	\$125.00	\$ 15,000.00		\$ 15,000.00
Construction Specialist		200.00	\$75.00	\$ 15,000.00		\$ 15,000.00
Superintendent		160.00	\$75.00	\$ 12,000.00		\$ 12,000.00
Apprentice		320.00	\$60.00	\$ 19,200.00		\$ 19,200.00
Programmer			\$150.00	\$ -		\$ -
				Labor TOTAL		\$ 61,200.00
Equipment						
Core Drill	0.00		\$4.00	\$ -	7.00%	\$0.00
Mini Excavator	80.00		\$16.76	\$ 1,340.80	7.00%	\$1,434.66
VIB Plate	80.00		\$5.92	\$ 473.60	7.00%	\$506.75
Diesel	200.00		\$3.13	\$ 625.00	7.00%	\$668.75
Small Tools	2,500.00		\$2.00	\$ 5,000.00	7.00%	\$5,350.00
				Equipment TOTAL		\$7,960.16
Materials						
Electrical Quote	1 LS	0.00		\$ 164,056.00	7.00%	\$175,539.92
			\$0.00	\$ -	7.00%	\$0.00
			\$0.00	\$ -	7.00%	\$0.00
				Material TOTAL		\$175,539.92

	Total	\$244,700.08
OH & P	20%	\$ 48,940.02
GRAND TOTAL		\$ 293,640.09

2ea Additional Wells Work Breakdown		
Intruments Power Conduits and Wire	\$	13,583.58
Intruments Control Conduits and Wire	\$	19,014.78
Wells 1-2 Grounding	\$	10,065.00
Submersible Pumps 75HP Conduits and Wire	\$	39,654.26
DP to Pumps CP Conduits and Wire	\$	46,898.04
Submersible Pumps Connection 75HP	\$	6,198.00
Intruments Installations and Connections	\$	28,642.34

2 CCI Electrical

■ **050 RTU w/Radios, Control Panel UPS, & Antenna**



4012 Gulfstream Dr
Bryan, TX 77808

CHANGE ORDER

CCI Electrical

▪ 050 RTU w/Radios, Control Panel UPS, & Antenna

Date: May 20, 2025

*Mr. Tommy Floyd
CDM Constructors Inc.*

Subject: ***Green Cay Phase 2 Progressive Design Build Addition of 2 Wells***

Dear Tommy Floyd,

CDM Constructors Inc. (CCI), a division of CDM Smith, presents this proposed change order related to the Additional 2 wells, requested by Palm Beach County (PBC) at Green Cay. The change order price is based on the inclusions/exclusions below:

This change order has been developed based on the Green Cay Phase 2 Green Cay Park Drawings and the Issued for Construction Specifications for the Green Cay Phase 2 Project.

Inclusions

1. Provide and Integrate RTU 3W-34 including radios, control panel UPS, and antenna.
2. Provide and Integrate RTU 3W-36 including radios, control panel UPS, and antenna.
3. Furnishing the instrumentation and stands for wells 3W-34 and 3W-36 to include one of the following at each site: Conductivity and Temperature Analyzer, ORP Analyzer, 10" Magnetic Flowmeter, Flow Switch, Submersible Level Transmitter, Pressure Gauge, and Pressure Transmitter
4. Submittals and O&Ms for RTU panels, Process Controls, and Instrumentation
5. Un-witnessed and Witnessed Factory Acceptance Test for RTU 3W-34 and 3W-36
6. Process controls testing per the specifications
7. Taxes are included in this proposal.





4012 Gulfstream Dr
Bryan, TX 77808

CHANGE ORDER

CCI Electrical

• 050 RTU w/Radios, Control Panel UPS, & Antenna

Clarifications:

1. This change order does not include install of control panels or instrumentation for well site 3W-34 or 3W-36
2. Raceways, wires, and terminations will be provided by others.
3. Radio Licenses will be provided and verified by the owner.

The proposal for this change order is: **\$ 330,269.65**

Three Hundred Thirty Thousand Two Hundred and Sixty-Nine Dollars and Sixty-Five Cents

Sincerely,

Bryan Craig
CDM Smith
4012 Gulfstream Dr.
Bryan, TX 77808
(214) 728-5528



H & J Contracting, Inc.

3160 Fairlane Farms Road
Wellington, FL 33414
USA

Phone: 561-791-1953
Fax: 561-795-9282

To: CDM Smith	Contact: Paul Saffirula
Address: 11490 Westheimer Road, Suite 700 Houston, TX 7077	Phone:
	Fax:
Project Name: Green Cay - Additional Well Fields (hard Pipe Option)	Bid Number:
Project Location:	Bid Date: 01/15/2026

Line #	Item #	Item Description	Estimated Quantity	Unit	Unit Price	Total Price
1) General Conditions						
	100	Mobilization	1.00	EACH	\$39,600.00	\$39,600.00
	110	Surveying	1.00	EACH	\$20,000.00	\$20,000.00
	120	Bond Fee	1.00	EACH	\$10,970.00	\$10,970.00
Total Price for above 1) General Conditions Items:						\$70,570.00
2) HDD						
	210	16" HDPE	500.00	LF	\$225.00	\$112,500.00
	240	HDD Pressure Testing	1.00	EACH	\$5,660.00	\$5,660.00
Total Price for above 2) HDD Items:						\$118,160.00
3) Utility Hard Piping						
	300	10" DIP Water Main	500.00	LF	\$165.00	\$82,500.00
	310	16" DIP Water Main	1,220.00	LF	\$260.00	\$317,200.00
	320	20" DIP Water Main	500.00	LF	\$356.00	\$178,000.00
	400	10" Gate Valve Assembly	4.00	EACH	\$7,810.00	\$31,240.00
	410	16" Gate Valve Assembly	4.00	EACH	\$17,440.00	\$69,760.00
	420	20" Gate Valve Assembly	2.00	EACH	\$21,768.00	\$43,536.00
	430	Pressure Testing	1.00	EACH	\$16,850.00	\$16,850.00
Total Price for above 3) Utility Hard Piping Items:						\$739,086.00
4) Restoration						
	500	Restoration Including HDD And Hard Piping Installation Areas (Installation Within Proposed Access Road)	1.00	EACH	\$180,384.00	\$180,384.00
	510	Grading Prep For Wells	3.00	EACH	\$11,900.00	\$35,700.00
Total Price for above 4) Restoration Items:						\$216,084.00
Total Bid Price:						<u>\$1,143,900.00</u>

Notes:

- This proposal is based on email dated 10/10/25 from Paul S. (CDM).
- Final quantities and total proposal amount to be confirmed once final plans are issued for construction. This proposal is for ROM (Budget) purposes only. Assumptions have been made. Material pricing is subject to change.
- Unless otherwise indicated, in writing, this quotation expires 12/31/2025.
- Proposal does not include root barrier.
- Proposal does not include landscape removal and disposal and/or irrigation restorations.

01/15/2026 2:16:33 PM



Spreadsheet Level	Takeoff Quantity	Labor Amount	Material Amount	Equip Amount	Sub Amount	Other Amount	Total Cost/Unit	Total Amount
3 CCI Mechanical								
060 Furnish Production Well AG Valves	8.00 ea		48,350				6,043.75 /ea	48,350
065 Furnish Production Well AG DIP & Accessories	24.00 lf		29,608				1,233.66 lf	29,608
080 Install Production Well Above Grade Piping	2.00 ea				109,444		54,722.00 /ea	109,444
085 Testing & Inspections Allowance	1.00 ls				23,735		23,735.00 /ls	23,735
090 Surveying Allowance	1.00 ls				23,735		23,735.00 /ls	23,735
3 CCI Mechanical			77,958		156,914			234,872

3 Clarifications & Exceptions



101 Southhall Lane Suite 200
Maitland, FL 32751
tel: 407-660-2552

April 08, 2026 | Additional North Production Wells 3W-34 & 3W-36

CLARIFICATIONS & EXCEPTIONS:

- **The scope added by this proposal is not to be used in assessing liquidated damages for Substantial Completion or Final Completion of the Project as a whole. Design-Builder reserves the right to seek additional time in a zero-cost change order, based on the actual schedule impacts observed, supported by a time impact analysis.**
- Proposal pricing is valid for 30 calendar days from the date of issue and is subject to re-verification upon expiration or acceptance beyond this period.
- FPL feed is limited to 50 linear feet maximum. Additional length will be subject to additional cost.
- Lead times and shipping durations are subject to current market conditions and supplier commitments at the time of order.
- This proposal does not account for design changes, scope redefinition, or field conditions not known at the time of pricing – this proposal contains \$170,000 of contingency for any scope gaps, changes, and/or design related costs. Any remaining balanced will be sent to Design-Builder contingency.
- All work is contingent upon written approval of this change order.
- Spares and special tools are not included unless explicitly stated in this proposal.
- Permits and utility connection charges are excluded unless otherwise noted.
- Radio licenses to be provided, paid for, and coordinated by the Owner.
- No lamps, fuses, or accessories are included unless explicitly noted.
- PCO 008 includes an allowance of \$250,000 for work to be completed by Florida Power & Light (FPL), Owner's utility provided. It is expressly acknowledged and agreed that the allowance is not a representation or guarantee that the work within the allowance can be performed for the allowance value, and Owner will issue a change order for the actual amount incurred for FPL's work.

4 Schedule





■ **PCO 009**

Chemical Canopy - Tnemec Paint

	PCO 009 - Chemical Canopy - Tnemec Paint	SUBTOTAL	\$	13,164.60
CCI Constructors, Inc.	Design-Builder OH&P (+11%)		\$	1,304.60
Advanced Painting	Add Tnemec		\$	11,860.00

Palm Beach County Water Utilities Department
 Green Cay Phase II, Water Purification and Park
 Flavor Pict Road, Boyton Beach, Florida
 Progressive Design-Build
 CDM Smith



Date: 09/02/25

Green Cay Phase II, ADD Tnemec to Chemical Canopy Change Request Breakdown

Add Tnemec to coatings for Chemical Containment Area	\$ 4,860.00
Add Tnemec to coatings for Steel Primaries - Columns & Rafters	\$ 3,500.00
Add Tnemec to coatings for Purlins at Metal Canopy	\$ 3,500.00
Builders Risk Insurance	\$ -
General Liability	\$ -
Design-Builder Bonds	\$ -
Florida Bond Surcharge	\$ -
Design-Builder OH&P (+11%)	\$ 1,304.60
TOTAL	\$ 13,164.60



101 Southhall Lane Suite 200
Maitland, FL 32751
tel: 407-660-2552

September 02, 2025

Ms. Jie "Jane" House, P.E., LEED AP
Director of Engineering
Palm Beach County Water Utilities Department (PBCWUD)

Subject: Green Cay Phase 2 Progressive DB Project
RE: Potential Change Order No. 009 – Chemical Canopy Tnemec Paint

Dear Ms. House:

CDM Constructors Inc. (Design-Builder) has received the Palm Beach County Water Utilities Department (PBCWUD) request for changing the chemical canopy paint product to the Tnemec in lieu of subcontractor, Advance Painting Contractors, Inc. selected product. In coordination with subcontractor, the Design-Builder has evaluated the request for associated cost.

This proposal includes additional cost and profit for switching to Tnemec. Should PBCWUD wish to proceed, please review and issue an Amendment to increase the Guaranteed Maximum Price (GMP) by **\$13,164.60**.

If you have any questions or concerns, please contact us.

Sincerely,

Paul Safirulla,
Project Manager
CDM Smith Inc.

cc: CDM Smith, Inc: Tommy Floyd, Suzanne Mechler, David Atwood
Hazen and Sawyer: Richard Davis

Attached(s): PCO-009 Backup





7369 Westport Place
West Palm Beach, Florida 33413

(561) 845-0123
(800) 232-1584
fax (561) 697-9815
CC # U22463
danny@advanced-painting.com

BID PROPOSAL

JOB NAME:

GREEN CAY - PHASE 2
Coatings for Chemical Containment Area and New Piping & Pieces
12751 Hagen Ranch Rd. - Boynton Beach, FL 33437

BID TO: **Paul Safirulla**
CONTRACTOR: **CDM Smith**
ADDRESS: 621 NW 53rd St Ste 265
Boca Raton, FL 33487

PHONE#: _____
FAX#: _____
CELL#: **(904) 233-1879**
EMAIL: **safirullana@cdmsmith.com**

BID DUE DATE: **9/1/23**

BID BY: **Daniel Eggertsson**

SCOPE: **Coatings for Chemical Containment Area and New Piping & Pieces**

- The concrete areas of the Chemical Containment Area - Walls, Slab, Sumps, etc. will be prepped for coatings by pressure cleaning per specifications.
- Once the surface has been prepped, we will apply a primer coat of Tnemec ChemBloc® Series 251SC Chemical Resistant Primer, an intermediate coat of Tnemec ChemBloc® Series 252SC Fiberglass Mat Reinforced Vinyl Ester Lining with Glass Mat and a topcoat with Tnemec ChemBloc® Topcoat Series 252SC, color to be one of their pre-mixed standard colors - TBD.
- The pipes, fittings, valves, etc. for the Process Piping in the Chemical Area, WPF and Park Wells will be prepped by sanding, wire brushing and solvent wiping.
- We will then spot prime rust areas with Tnemec Tneme-Zinc® 90-97 Zinc Rich Primer, one coat of Tnemec Hi-Build Epoxoline® Series 66 Polyamide Epoxy and finish painted with Tnemec Endura-Shield® Series 1095 Aliphatic Acrylic Polyurethane, color(s) TBD.

TNEMEC: Per Owner request, we will switch from the approved SWP products to the requested Tnemec products and this will result in an EXTRA for additional freight charges as well as the difference in the material cost.

- Quote includes all Labor & Materials. **All work must be completed during normal business hours 7:30-5PM, M-F only. Weekend and/or OT Labor will incur additional charges.

MOBILIZATION:	\$3,000.00
DEMOBILIZATION:	\$4,000.00
TEMPORARY FACILITIES:	\$2,000.00
PERMITS:	\$0.00
SALES & USES TAXED:	INCLUDED
BOND & INSURANCE:	\$3,600.00
INTERIOR FLOORING & CONCRETE:	\$6,000.00
CHEMICAL CONTAINMENT - PREP:	\$24,000.00
CHEMICAL CONTAINMENT - COATINGS:	\$32,000.00
PROCESS PIPING - CHEMICAL AREA:	\$16,700.00
PROCESS PIPING - WPF:	\$18,700.00
PROCESS PIPING - PARK WELLS:	\$8,000.00
COMBINED TOTAL:	\$118,000.00
ADD TNEMEC:	\$4,860.00

EXCLUSIONS: Work is only as described above. Any additional work requested will be priced out for approval prior to commencement of same.

PAYMENT: Per Contractor's Regular Draw Schedule.

NOTE: All paint materials are to be quality products as manufactured by PPG or Equal unless specifically noted otherwise. This Bid Proposal is valid for **90 Days Only**, after which time the undersigned has the right to void or extend. Please call if there are any questions concerning this bid.

Signed: Daniel Eggertsson
advanced painting contractors, inc.

8/27/25
date

Approved: _____
CDM Smith

_____ date



7369 Westport Place
West Palm Beach, Florida 33413

(561) 845-0123
(800) 232-1584
fax (561) 697-9815
CC # U22463

danny@advanced-painting.com

BID PROPOSAL

JOB NAME:

GREEN CAY - PHASE 2 - WPF CHEMICAL CANOPY
Priming and Painting of Steel Primaries - Columns and Rafters on New 120'-7" x 34'-2" Metal Canopy - Tnemec
12751 Hagen Ranch Rd. - Boynton Beach, FL 33437

BID TO:

Paul Safirulla
CONTRACTOR: CDM Smith
ADDRESS: 621 NW 53rd St Ste 265
Boca Raton, FL 33487

PHONE#:

FAX#:

CELL#:

EMAIL:

(904) 233-1879
safirullapa@cdmsmith.com

BID DUE DATE:

ASAP

BID BY:

Daniel Eggertson

SCOPE:

Priming and Painting of Steel Primaries - Columns and Rafters on New 120'-7" x 34'-2" Metal Canopy - Tnemec

- Scope will include the steel primaries on the New 120'-7" x 34'-2" WTF Chemical Canopy.
- There will be (16) Steel Columns and (8) Steel Rafters.
- We request to paint the steel primaries on the ground before they are erected, and we will then touch-up once erected.
- On the ground, we will prep the factory-primed Steel Columns and Steel Rafters by sanding and solvent wiping as needed.
- Per Tnemec Spec, we will spot prime any rust areas with Tnemec *Tneme-Zinc*® 90-97 Zinc Rich Primer.
- We will then apply one coat of Tnemec *Hi-Build Epoxoline*® Series 66 Polyamide Epoxy.
- Lastly, we will finish paint the Steel Columns and Steel Rafters with two coats of Tnemec *Endura-Shield*® Series 1095 Aliphatic Acrylic Polyurethane, color TBD.
- GC will then erect the canopy and install the roof. We will then touch-up the Steel Columns and Steel Rafters as needed.

ALTERNATE:

There will be an ADD to comply with the Davis Bacon 2023 Wage Decision and submit the certified payroll weekly for the project.

TNEMEC:

Per Owner request, we will switch from the approved SWP products to the requested Tnemec products and this will result in an EXTRA for additional freight charges as well as the difference in the material cost.

EXCLUSIONS:

- ****Specifically Excluded: all secondaries, girts, purlins, roof underside, bolts and connectors.**
- Quote includes all Labor, Materials & Equipment. **All work must be completed during normal business hours 7:30-5PM, M-F only. Weekend and/or OT Labor will incur additional charges.

JOB TOTAL:	\$28,240.00
ADD DAVIS BACON 2023:	\$5,930.00
ADD TNEMEC:	\$3,500.00
CHANGE ORDER TOTAL:	\$37,670.00

EXCLUSIONS:

Work is only as described above. Any additional work requested will be priced out for approval prior to commencement of same.

PAYMENT:

Per Contractor's Regular Draw Schedule.

NOTE:

All paint materials are to be quality products as manufactured by PPG, Sherwin-Williams or Equal unless specifically noted otherwise. This Bid Proposal is valid for **30 Days Only**, after which time the undersigned has the right to void or extend. Please call if there are any questions concerning this bid.

Signed:

Daniel Eggertson

advanced painting contractors, inc.

8/27/25

date

Approved:

CDM Smith

date



7369 Westport Place
West Palm Beach, Florida 33413

(561) 845-0123
(800) 232-1584
fax (561) 697-9815
CC # U22463

danny@advanced-painting.com

BID PROPOSAL

JOB NAME:

GREEN CAY - PHASE 2 - WPF CHEMICAL CANOPY

Extra Work - Add Purlins - Tnemec
12751 Hagen Ranch Rd. - Boynton Beach, FL 33437

BID TO:

Paul Safirulla
CONTRACTOR: CDM Smith
ADDRESS: 621 NW 53rd St Ste 265
Boca Raton, FL 33487

PHONE#:

FAX#:

CELL#:

EMAIL:

(904) 233-1879

safirullapa@cdmsmith.com

BID DUE DATE:

ASAP

BID BY:

Daniel Eggertsson

SCOPE:

Extra Work - Add Purlins - Tnemec

- Scope will include the Purlins on the New 120'-7" x 34'-2" WTF Chemical Canopy.
- There will be 1502.2 LF of the main Purlins and 780.98 LF of additional Purlins.
- We request to paint the purlins on the ground before they are erected, and we will then touch-up once erected. CDM will provide a layer on the ground to keep the dirt from blowing up as well as some perimeter containment such as a silt fence to keep the wind from blowing dirt on the surface.
- On the ground, we will prep the galvanized Purlins by applying *ChemfosKA*® to the surface and pressure cleaning off with a *Hotsy*® Machine at 180 degrees.
- Per Tnemec Spec, we will spot prime any rust areas with Tnemec *Tneme-Zinc*® 90-97 Zinc Rich Primer.
- We will then apply one coat of Tnemec *Hi-Build Epoxoline*® Series 66 Polyamide Epoxy.
- Lastly, we will finish paint the Purlins with two coats of Tnemec *Endura-Shield*® Series 1095 Aliphatic Acrylic Polyurethane, color TBD.
- GC will then erect the canopy and install the roof. We will then touch-up the Purlins as needed.

ALTERNATE:

There will be an ADD to comply with the Davis Bacon 2023 Wage Decision and submit the certified payroll weekly for the project.

TNEMEC:

Per Owner request, we will switch from the approved SWP products to the requested Tnemec products and this will result in an EXTRA for additional freight charges as well as the difference in the material cost.

- Quote includes all Labor, Materials & Equipment. **All work must be completed during normal business hours 7:30-5PM, M-F only. Weekend and/or OT Labor will incur additional charges.

EXTRA WORK TOTAL:	\$31,800.00
ADD DAVIS BACON 2023:	\$6,360.00
ADD TNEMEC:	\$3,500.00
CHANGE ORDER TOTAL:	\$41,660.00

EXCLUSIONS:

Work is only as described above. Any additional work requested will be priced out for approval prior to commencement of same.

PAYMENT:

Per Contractor's Regular Draw Schedule.

NOTE:

All paint materials are to be quality products as manufactured by PPG, Sherwin-Williams or Equal unless specifically noted otherwise. This Bid Proposal is valid for **30 Days Only**, after which time the undersigned has the right to void or extend. Please call if there are any questions concerning this bid.

Signed:

Daniel Eggertsson

advanced painting contractors, inc.

8/26/25

date

Approved:

CDM Smith

date



■ **PCO 010**

Balance of Park Picnic Tables

	PCO 010 – Balance of Park Picnic Tables	SUBTOTAL	\$	19,675.11
CCI Constructors, Inc.	Design-Builder OH&P (+11%)		\$	1,949.79
Rep Services	Balance of Picnic Tables, Benches & Concrete Pad		\$	17,725.32



101 Southhall Lane Suite 200
Maitland, FL 32751
tel: 407-660-2552

May 12, 2025

Ms. Jie "Jane" House, P.E., LEED AP
Director of Engineering
Palm Beach County Water Utilities Department (PBCWUD)

Subject: Green Cay Phase 2 Progressive DB Project
RE: Potential Change Order No. 010 – Balance of Picnic & Serving Tables (ADA & Non-ADA)

Dear Ms. House:

Please review the attached PCO-010 for the balance of the requested Picnic Tables (both ADA & Non-ADA), and Serving Tables to be upgrades to "Antique Mahogany Plastic" in lieu of "Douglas Fir".

If you have any questions or concerns, please contact us.

Sincerely,



Paul Safirulla,
Project Manager
CDM Smith Inc.

cc: CDM Smith, Inc: Tommy Floyd, Suzanne Mechler, David Atwood
Hazen and Sawyer: Richard Davis

Attached(s): PCO-010 Backup



Palm Beach County Water Utilities Department
 Green Cay Phase II, Water Purification and Park
 Flavor Pict Road, Boyton Beach, Florida
 Progressive Design-Build
 CDM Smith



Electronic
Date: Monday, May 12, 2025

**GREEN CAY PHASE 2, BALANCE OF PARK PICNIC TABLES
 CHANGE REQUEST BREAKDOWN**

Park Picnic Tables, Benches & Concrete Pads - Direct Cost	\$17,725.32
Builders Risk Insurance	\$0
General Liability	\$0
Design-Builder Bonds	\$0
Design-Builder General Conditions	\$0
Design-Builder OH&P	\$1,949.79
Total GMP	\$19,675.11

Confidential trade secret information exempt from disclosure under applicable public records law



REP SERVICES, INC.
Experts at Play & Outdoor Spaces

165 W. Jessup Avenue
 Longwood, FL 32750-4146
 PH: 407-831-9658
 FAX: 866-232-8532
 info@repervices.com
 www.repervices.com

Change Order Request #5

To: Paul Safrulla **From:** Jacqui Rohrborn
Co: CDM Constructors Inc. **Co:** Rep Services, Inc.
 165 W. Jessup Avenue
 Longwood, FL 32750-4146
Date: 04/17/2025
Re: Green Cay
 For your reference, our project number is: 20068.

The original Subcontract/ Agreement Price was..... \$574,053.13
 Net change by previously authorized Change Orders #1..... \$ 9,241.00
 The Subcontract/ Agreement Price prior to this Change Order was..... \$583,294.13
 The NEW Subcontract/ Agreement Price due to this Change Order is.....\$583,294.13
 Deduct due to changes is DuMor Site Furnishings is..... (\$ 51,799.04)
 Subtotal..... \$531,495.09
 Add for Revised Quantities and Various Finishes \$ 99,533.09
 Add for Change Order #4 (Bench 34-60TX to 58-60 Metal with Plaque Inserts and
 Future Memorial Plaques) \$12,847.20
 Subtotal Subcontract..... \$643,875.38
 Addition Change Order #5 change to material from Douglas Fir
 to Antique Mahogany TX for Pavilion Tables, Standard, ADA and Plate Tables... \$17,725.32
 Total New Subcontract..... \$661,600.70

\$16,722.00 +\$1,003.32 (6% taxes) \$17,725.32 (total)

Site Amenities ■ Playground Equipment ■ Safety Surfacing ■ Shade & Shelters



101 Southhall Lane Suite 200
Maitland, FL 32751
tel: 407-660-2552

April 14, 2025

Ms. Jie "Jane" House, P.E., LEED AP
Director of Engineering
Palm Beach County Water Utilities Department (PBCWUD)

Subject: Green Cay Phase 2 Progressive DB Project
RE: Potential Change Order No. 010 – Park Picnic & Serving Tables

Dear Ms. House:

During the finalization of Change Order No. 3 that includes PCO-007, which address the Park site furnishings, PBCWUD's onsite representative requested replacing the remaining "Douglas Fir" pavilion tables with "Antique Mahogany Recycled Plastic" as part of PCO-007.

To avoid delaying the progress associated with CO#3/PCO-007, CDM Smith is pricing this revision separately and will submit a proposal as soon as practical.

Upon acceptance of our proposal and issuance of a formal Change Order by PBCWUD, CDM Smith will proceed with the requested modifications.

Please don't hesitate to reach out with any questions or concerns.

Sincerely,

Paul Safirulla,
Project Manager
CDM Smith Inc.

cc: CDM Smith, Inc: Tommy Floyd, Suzanne Mechler, David Atwood
Hazen and Sawyer: Richard Davis

Attached(s): (1 page) CDM's Email to Rep Services, Inc.



From: Safirulla, Paul A.
 Sent: Monday, April 14, 2025 1:52 PM
 To: jacqui@repservices.com; Fitzgerald, Breyden A. <fitzgeraldba@cdmsmith.com>; Atwood, David A. <atwoodda@cdmsmith.com>; pbravo@repservices.com
 Cc: JHouse@pbcwater.com; RDavis@hazenandsawyer.com
 Subject: Change Order Request - ATN: Jacqui - RE: RSI 20068 RE: 20-036 Green Cay 2 - Tables under Parilions

Good morning Jacqui,

I've copied the client on this email to keep them informed of our coordination efforts.

While wrapping up CO#3 (PCO#007), the client requested changes to items #5, #6, and #7. Due to timing constraints, we finalized CO#3 without these changes (removing Douglas Fir) and advised the client that we would follow up with a separate Change Order (replacing Douglas Fir with Antique Mahogany).

FULL LIST PER CO#3 (PCO#007) – CURRENTLY BEING APPROVED

1. (15) 6' Steel Park Benches with insert, plaque, and armrests (PARK)
2. (4) Antique Mahogany Recycled Plastic ADA Picnic Tables (PARK)
3. (14) 8' Antique Mahogany Recycled Plastic Non-ADA Picnic Tables (PARK)
4. (10) Grill with embedment sleeve
5. (2) 6' Douglas Fir Serving Tables (PAVILION)
6. (2) Douglas Fir ADA Picnic Tables (PAVILION)
7. (8) 8' Douglas Fir Non-ADA Picnic Tables (PAVILION)

We would like to change the Douglas Fir with **Antique Mahogany Recycled Plastic**.

THE CHANGES:

5. (2) 6' Antique Mahogany Recycled Plastic Serving Tables (PAVILION) (last known pricing: \$1,515)
6. (2) Antique Mahogany Recycled Plastic ADA Picnic Tables (PAVILION) (last known pricing: \$2,856)
7. (8) 8' Antique Mahogany Recycled Plastic Non-ADA Picnic Tables (PAVILION) (last known pricing: \$2,675)

Please provide a quote that credits items 5 to 7 (Douglas Fir) and update 5 to 7 with Antique Mahogany Plastic.

The new OVERALL list that your pricing should look like this:

1. (15) 6' Steel Park Benches with insert, plaque, and armrests (PARK)
2. (4) Antique Mahogany Recycled Plastic ADA Picnic Tables (PARK)
3. (14) 8' Antique Mahogany Recycled Plastic Non-ADA Picnic Tables (PARK)
4. (10) Grill with embedment sleeve
5. (2) 6' Antique Mahogany Recycled Plastic Serving Tables (PAVILION)
6. (2) Antique Mahogany Recycled Plastic ADA Picnic Tables (PAVILION)
7. (8) 8' Antique Mahogany Recycled Plastic Non-ADA Picnic Tables (PAVILION)

I'm assuming the math should look something like this:

	EACH	QTY	SUBTOTAL
ADD			
5. (2) 6' Antique Mahogany Recycled Plastic Serving Tables (PAVILION)	\$1,515.00	2	\$ 3,030.00
6. (2) Antique Mahogany Recycled Plastic ADA Picnic Tables (PAVILION)	\$2,856.00	2	\$ 5,712.00
7. (8) 8' Antique Mahogany Recycled Plastic Non-ADA Picnic Tables (PAVILION)	\$2,675.00	8	\$ 21,400.00
CREDIT			
5. (2) 6' Douglas Fir Serving Tables (PAVILION)	\$1,110.00	-2	\$ (2,220.00)
6. (2) Douglas Fir ADA Picnic Tables (PAVILION)	\$1,140.00	-2	\$ (2,280.00)
8. (8) 8' Douglas Fir Non-ADA Picnic Tables (PAVILION)	\$1,115.00	-8	\$ (8,920.00)
			\$16,722.00 TOTAL

If you have any questions or concerns regarding this quote, please reach out.

Paul Safirulla, Assoc. DBIA™
 Project Manager, CDM Smith
 101 Southhall Ln #200
 Maitland, FL 32751
 C: 904-233-1879
 cdmsmith.com

ALL DIMENSIONS UNLESS OTHERWISE SPECIFIED ARE IN INCHES. DIMENSIONS IN PARENTHESES ARE TYPICAL. DIMENSIONS IN BRACKETS ARE ALTERNATE. DIMENSIONS IN BOLD FACE ARE TO BE USED IN WHOLE OR PART, FOR ANY OTHER PROJECT WITHOUT THE WRITTEN AUTHORIZATION OF CDM SMITH.

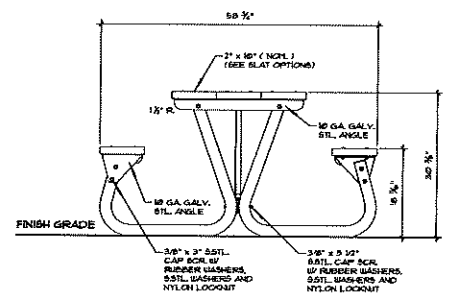

23.01-Picnic Table Side Elevation
(Traditional and ADA Picnic Table) 1" = 1'-0"

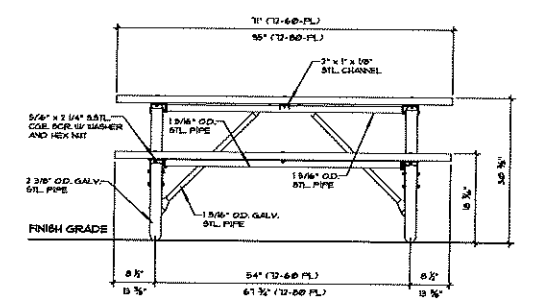

23.02-Picnic Table Front Elevation
(Traditional Picnic Table) 1" = 1'-0"

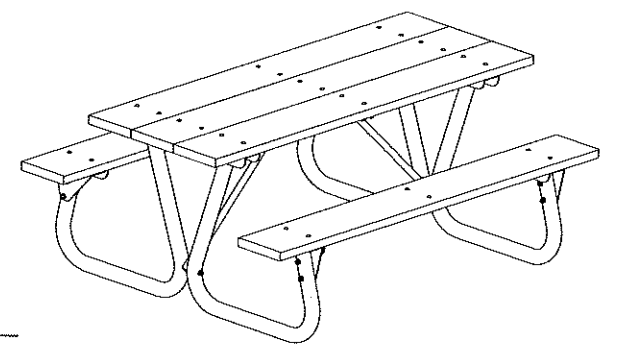

23.03-Picnic Table Isometric View
(Traditional Picnic Table) N.T.S.

ANCHORING NOTE:

- 1/2" x 3/4" EXPANSION ANCHORS AND 2"

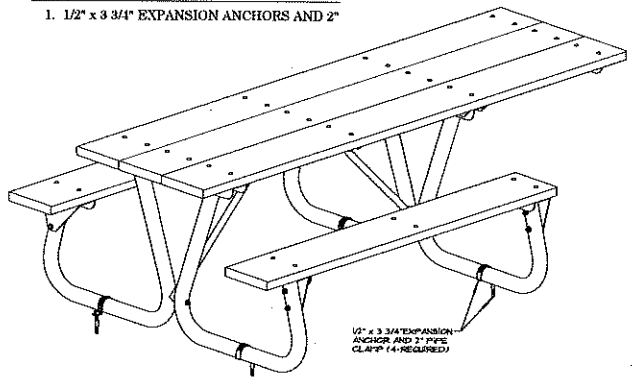

23.04-Picnic Table Isometric View
(ADA Picnic Table) N.T.S.

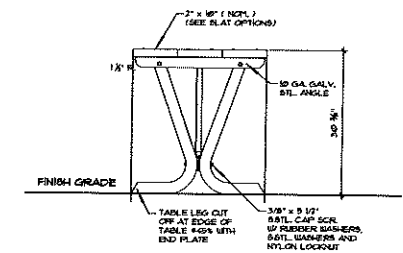
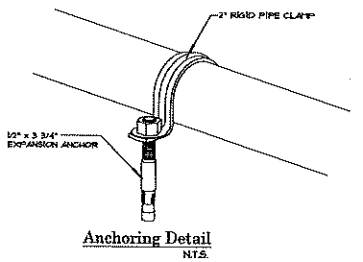

23.06-Serving Table Side Elevation
1" = 1'-0"

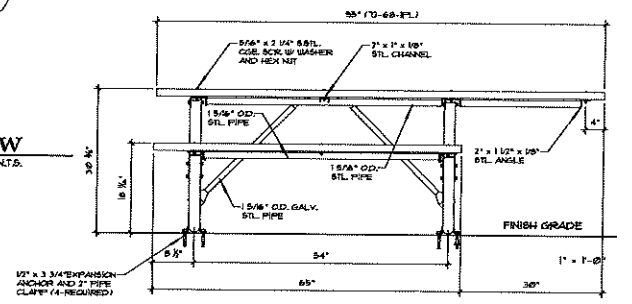

23.05-Picnic Table Front Elevation
(ADA Picnic Table) 1" = 1'-0"

DuMor, Inc.
72-68 SERIES PL
ADA PICNIC TABLE
72 SERIES PL
PICNIC TABLE

SLAT FINISHES

- IS "ANGIOME (MANGIOME)" TEXTURED RECYCLED PLASTIC FOR ALL TABLES ANCHORED OUTSIDE ON SLABS
- IS DOWELBAR FOR 648 BE-8 FOR PAVILION TABLES FOR ALL TABLES PLACED IN PAVILION

LENGTH OPTIONS

- IS 6' TABLE - SERVING
- IS 8' TABLE - ALL PURPOSE

METAL FRAME FINISH

- IS HOT DIPPED GALVANIZED

2GHO
Landscape Architects/Planners/Environmental Consultants
107 Cedar Ave., Suite 100 Palm Beach, Florida 33480

REV. NO.	DATE	BY	CHKD.	DESCRIPTION	REMARKS

DESIGNED BY: E. O'MAHONEY
DRAWN BY: E. O'MAHONEY
CHECKED BY: E. RODEN
APPROVED BY: E. O'MAHONEY
DATE: MARCH 2024



PALM BEACH COUNTY WATER UTILITIES
GREEN CAY PHASE 2
GREEN CAY PARK

SITE DETAILS XII - SITE FURNITURE

DATE: 03/11/24
DRAWN BY: E. O'MAHONEY
PROJECT NO: 4711-240864
SHEET NO: 26-1007
SHEET NO: SP-23

NOTE: DUMOR, INC. PRODUCTS ARE TYPICAL PALM BEACH COUNTY PARK STANDARDS AND ARE THE BASIS OF DESIGN.

NOTE: EACH PAVILION TO RECEIVE THE FOLLOWING TABLES:
(2) SERVING TABLES - 6' WITH NO SEATS
(2) ACCESSIBLE 8' TABLES
(2) STANDARD 8' TABLES

THIS ITEM HAS BEEN DIGITALLY SIGNED BY EYAL L. RODEN ON THE DATE ADJACENT TO THE SEAL.
PRINTED COPIES OF THIS DOCUMENT ARE NOT CONSIDERED SIGNED AND SEALED AND THE SIGNATURE MUST BE VERIFIED ON ANY ELECTRONIC COPIES.

■ **PCO 011**

WPF Irrigation Upgrades

	PCO 011 – WPF Irrigation Upgrades	SUBTOTAL	\$	26,738.45
CCI Constructors, Inc.	Design-Build OH&P (+11%)		\$	2,463.45
2GHO - Landscape EOR	ESDC for Landscape EOR (no markups applied to this line.)		\$	1,880.00
A Cut Above	Add WPF Irrigation Upgrades		\$	22,395.00

Palm Beach County Water Utilities Department
 Green Cay Phase II, Water Purification and Park
 Flavor Pict Road, Boyton Beach, Florida
 Progressive Design-Build
 CDM Smith



Date: 09/03/25

Green Cay Phase II, ADD Park Irrigation Upgrades

Upgrades Irrigation System		\$ 22,395.00
Builders Risk Insurance		\$ -
General Liability		\$ -
Design-Builder Bonds		\$ -
Florida Bond Surcharge		\$ -
Design-Builder OH&P (+11%)		\$ 2,463.45
Engineering - 2GHO - Landscape Architect		
ESDC		\$ 1,880.00
TOTAL		\$ 26,738.45



101 Southhall Lane Suite 200
Maitland, FL 32751
tel: 407-660-2552

September 03, 2025

Ms. Jie "Jane" House, P.E., LEED AP
Director of Engineering
Palm Beach County Water Utilities Department (PBCWUD)

Subject: Green Cay Phase 2 Progressive DB Project
RE: Potential Change Order No. 011 – WPF Irrigation Upgrades

Dear Ms. House:

CDM Constructors Inc. (Design-Builder) has confirmed the pricing for Palm Beach County Water Utilities Department (PBCWUD) request for changing the irrigation system from Rain Bird to Baseline. In coordination with subcontractor, the Design-Builder is presenting the cost for this change.

This proposal includes additional cost and profit for changing irrigation system to Baseline. Should PBCWUD wish to proceed, please review and issue an Amendment to increase the Guaranteed Maximum Price (GMP) by **\$26,738.45**.

If you have any questions or concerns, please contact us.

Sincerely,

Paul Safirulla,
Project Manager
CDM Smith Inc.

cc: CDM Smith, Inc: Tommy Floyd, Suzanne Mechler, David Atwood
Hazen and Sawyer: Richard Davis

Attached(s): PCO-011 Backup





101 Southhall Lane Suite 200
Maitland, FL 32751
tel: 407-660-2552

September 03, 2025 | Park Irrigation Upgrades

CLARIFICATIONS & EXCEPTIONS:

- ▣ The quantities shown on the subcontractors, A Cut Above, proposal may differ once design is completed.
- ▣ Proposal pricing is valid for 30 calendar days from the date of issue and is subject to re-verification upon expiration or acceptance beyond this period.
- ▣ Overtime, shift work, acceleration, or standby time is not included unless specifically requested and priced separately.
- ▣ All work is based on a standard 40-hour work week; no premium time or weekend labor is included.
- ▣ Pricing is based on uninterrupted access to the work area and continuous work sequence; delays or resequencing may require additional costs.
- ▣ This proposal does not account for design changes, scope redefinition, or field conditions not known at the time of pricing.
- ▣ The Design-Builder reserves the right to make claim for impacts related to delays, disruption, escalation, or change in sequence resulting from others.
- ▣ All work is contingent upon written approval of this change order. Work performed prior to written approval is under protest.
- ▣ Final contract terms, including payment terms, retainage, and release provisions, apply to this change unless otherwise amended in writing.
- ▣ Spares and special tools are not included unless explicitly stated in this proposal.

A CUT ABOVE

LANDSCAPE & IRRIGATION

Design • Installation • Maintenance

1686 D ROAD
 LOXAHATCHEE, FL 33470
 561.795.1995 - PH
 561.795.8898 - FX



NAME/ADDRESS
CDM Constructors Inc. 555 17th Street Suite 500 Denver, CO 80202

CHANGE ORDER REQUEST

PBC SBE Vendor #VC0000009701

DATE	COR #
7/8/2025	18322

DESCRIPTION	QTY	COST	TOTAL
RE: GREEN CAY (IRRIGATION BASELINE CONTROLLER UPGRADE) CO			
ACA to provide any/all necessary equipment, labor, supervision, materials and supplies to complete the following:			
BaseLine 3200 Controller	1	4,100.00	4,100.00
BaseLine Tipping Bucket Rain Sensor	1	1,200.00	1,200.00
Soil Sensor	21	320.00	6,720.00 1,920
Verizon Cellular Modular and Antenna Kit	1	1,550.00	1,550.00
Conduit for 2-wire		6,800.00	6,800.00
Field Ground (Grounding rod and wire)	4	500.00	2,000.00
Decoder	21	300.00	6,300.00 1,800
3" PVC Flow sensor		1,525.00	1,525.00
Note: +\$3,500 for a 3" metal Hydrometer			+3,500
Credit for Rainbird Controller and Rain Sensor	-1	2,000.00	-2,000.00
			\$22,395.00
CUSTOMER AUTHORIZATION: X _____		TOTAL	\$28,195.00

ALL LANDSCAPING SHALL BE INSTALLED ACCORDING TO SOUND NURSERY PRACTICES AND SHALL BE FLORIDA NO. 1 OR BETTER AS GIVEN IN GRADES AND STANDARDS FOR NURSERY "PLANTS", STATE OF FLORIDA, DEPARTMENT OF AGRICULTURE. YOUR SIGNATURE ABOVE CONFIRMS YOUR UNDERSTANDING OF ACA'S COLLECTION POLICY AND GRANTS PERMISSION TO ACA TO COMMENCE PROPOSED WORK.

PRICING IS VALID FOR 30 DAYS FROM DATE OF PROPOSAL

Inter-Office Memorandum

Palm Beach County



Water Utilities Department

DATE: April 10, 2026
TO: File
FROM: Jane House *JH*
PBCWUD Director of Engineering
SUBJECT: Change Order No. 4
WUD Project No. 20-036
Green Cay Phase 2 Progressive Design-Build

=====

Change Order 4 in the amount of \$4,997,478.80 consists of owner initiated potential change orders (PCO).

PCO 008 in the amount of \$4,938,170.64 is for installing new production wells 3W-34 and 3W-36 at the new Green Cay Park. WUD's intent is to have a total of four production wells installed under this project. PCO 008 will be partially reimbursed by FY25 Alternative Water Supply grant and the grant deadline is June 2027. This PCO will have no impact to the original contractual milestones as it has its standalone milestones dates, substantial and final completions. The liquidated damages are \$500/day and \$250/day, respectively. The durations are 300 and 330 calendar days respectively.

PCO 009 in the amount of \$13,164.60 is to switch paint to Tnemec product for the chemical canopy at the Reuse facility, which is different than what's included in the original GMP.

PCO 010 in the amount of \$19,675.11 is to change the material from Douglas Fir to Antique Mahogany for the pavilion tables at the new Green Cay Park.

PCO 011 in the amount of \$26,738.45 is to revise irrigation system at Reuse facility to match the latest design for South Region Water Reclamation Facility.

Thank you.



July 16, 2025

Mr. Tommy Floyd, Vice President
CDM Constructors, Inc.
75 State Street, Suite 701
Boston, MA 02109

Water Utilities Department
Engineering Division

8100 Forest Hill Blvd
West Palm Beach, FL 33413

(561) 493-6000

Fax: (561) 493-6085

www.pbcwater.com



Palm Beach County
Board of County
Commissioners

Maria G. Marino, Mayor

Sara Baxter, Vice Mayor

Gregg K. Weiss

Joel G. Flores

Marci Woodward

Maria Sachs

Bobby Powell Jr.

Interim County Administrator

Todd J. Bonlarron

"An Equal Opportunity Employer"

Official Electronic Letterhead

Re: Project Number: 20-036
Green Cay Phase 2 Progressive Design-Build
Notification of Contract Clauses No Longer Being
Enforced Pursuant to Emergency Ordinance 2025-014

Dear Mr. Floyd,

On June 3, 2025, the Board of County Commissioners (BCC) approved an emergency ordinance to suspend the race and gender conscious provisions of the County's EBO ordinance. The suspension will remain in effect for two years or until further direction by the BCC, whichever comes first. As a result, the provisions relating to minority/women-owned business enterprise (M/WBEs) participation contained in the contract document (R2021-1248) in Article 10.0 Subcontracting **will not be enforced** as of June 3, 2025, only the small business enterprise (SBE) provisions will apply.

Please sign below to acknowledge receipt of this notification. This acknowledgement will be included in, and made part of, the contract file.

Should you require any additional information please contact Ms. Christina Bervin at cbervin@pbcwater.com or at (561) 493 5203.

Cordially,

Jane House, P.E., LEED AP
Director of Engineering Division

Receipt Acknowledged and In Agreement:

CDM Constructors, Inc.

(Design-Build Entity)

Tommy Floyd

(Print Name)

(Signature)

08.08.2025

(Date)

Tommy L. Floyd

Digitally signed by Tommy L. Floyd
DN: C=US,
E=lfloyd@cdmsmith.com,
O=CDM Smith Inc.,
OU=CCI, CN=Tommy L. Floyd
Date: 2025.08.08
13:07:10-0400

ATTACHMENT 2
Location Map

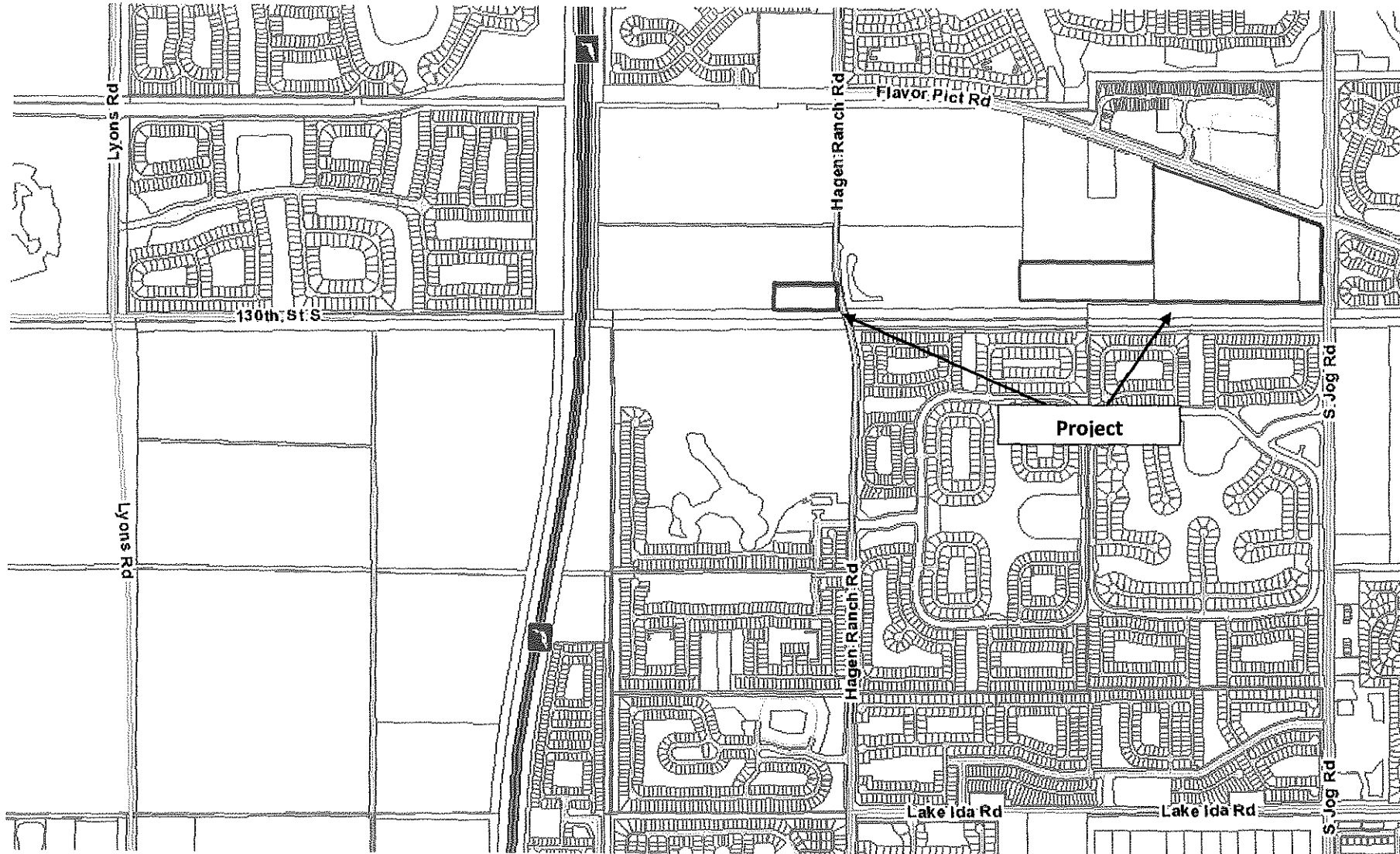

ATTACHMENT NO. 3

Print Date 4/10/2026 8:36:37 AM

Page 1 of 1



Palm Beach County Compliance Summary Report

Vendor Number	Vendor Name	AM Best Rating	Insurance Carrier	Policy #	Eff. Date	Exp. Date	Coverage	Contract Number	Contract Name
DX00001910	CDM Constructors, Inc.	Modified	Compliant					20-036	Green Cay Phase 2 Progressive Design-Build
		A+p , XV	Hartford Fire Insurance Company	08UENQU4162	1/1/2026	1/1/2027	Auto Liability		
		A+g , XV	Zurich American Insurance Company	CRT047239200	5/1/2024	8/1/2026	Builders Risk		
		A++g , XV	ACE Property and Casualty Insurance Company	xeug28194687010	1/1/2026	1/1/2027	Excess Liability		
		A+p , XV	Hartford Fire Insurance Company	08CSEQU4161	1/1/2026	1/1/2027	General Liability		
		NR , 0	Underwriters at Lloyd's London (IL)	PSDEF2600033	1/1/2026	1/1/2027	Professional Liability		
		A+p , XV	Hartford Accident and Indemnity Company	08WNQU4160	1/1/2026	1/1/2027	Workers Comp		

Risk Profile : Standard - Construction Services
Required Additional Insured : Palm Beach County Board of County Commissioners
Ownership Entity :



Inter-Office Communication
OFMB – Contract Development and Control Division

DATE: April 20, 2026
TO: Zachary Goetz, Contract Analyst
FROM: Brenda Znachko, Division Director
BCC MEETING DATE: 5/5/2026
AGENDA ITEM #: 3H7
DEPARTMENT #: FDO
DESCRIPTION: Motion to A) approve Agreement with Waste Mangement B) delegate authority to the CA to execute Agreement

Please review the attached Agenda Item package and return to me with your checklist and comments. Thank you.

Multiple horizontal lines for providing comments or checklists.

Table with 6 columns: DATE, CO - CSA - WO #, PROJECT #, PROJECT DESCRIPTION, AMOUNT, BALANCE

Total Items: Total Items w/Corrective Action Needed: Total Contract Related:

In System / Contract Register No. Not in System

DO ITEM(S) NEED TO BE ENTERED & TRACKED IN CONTRACT REGISTER?: YES NO