

**NOTES:**

1. OIL/GREASE INTERCEPTORS SHALL BE WATERTIGHT AND SHALL BE BUILT OF PRECAST CONCRETE WHICH HAS A DESIGN COMPRESSIVE STRENGTH OF MINIMUM 3000 PSI AFTER 28 DAYS CURE. THE DESIGN, SIZING AND CONSTRUCTION MUST CONFORM TO THIS STANDARD AND TO ALL APPLICABLE BUILDING CODES, HEALTH DEPARTMENT REQUIREMENTS AND REGULATIONS, INCLUDING, BUT NOT LIMITED TO CHAPTER 64E-6, FLORIDA ADMINISTRATIVE CODE. WALL AND SLAB THICKNESS SHOWN ARE MINIMUMS, AND SHALL BE DETERMINED BY THE OWNER'S ENGINEER. THE CONCRETE BOX SHALL BE MONOLITHIC POURED AND SHALL HAVE A PRECAST HOLE ON EACH END ONLY FOR LATERAL. THE PRECAST HOLES SHALL HAVE CAST-IN BOOTS WHENEVER POSSIBLE. AN ALTERNATIVE TYPE OF INTERCEPTOR OTHER THAN A PRECAST CONCRETE STRUCTURE MAY BE INSTALLED ONLY WITH PRIOR DEPARTMENT APPROVAL. SHOP DRAWINGS ARE REQUIRED TO BE SUBMITTED AND APPROVED BY THE DEPARTMENT PRIOR TO THE PRE-CONSTRUCTION MEETING FOR ALL INTERCEPTORS.
2. THE OIL/GREASE INTERCEPTOR SHALL BE USED FOR APPLICATIONS EXCEEDING 25 GPM FLOW RATE, DETERMINED USING THE PLUMBING AND DRAINAGE INSTITUTE PDI G101 STANDARD. A DESIGN CALCULATION MUST BE SUBMITTED FOR APPROVAL WITH A SHOP DRAWING PRIOR TO THE PRE-CONSTRUCTION MEETING. FOR APPLICATIONS UP TO 25 GPM FLOW RATE (ONE MINUTE FLOW) OR 50 GPM (TWO MINUTE FLOW), AN APPROVED OUTDOOR "GREASE TRAP" MAY BE USED; OTHER DESIGNS MAY BE CONSIDERED UPON SUBMITTAL AND APPROVAL OF SHOP DRAWINGS.
3. INSPECTION PORTS (CLEAN OUTS) ARE REQUIRED TO BE INSTALLED AT EACH END OF ANY TYPE OF INTERCEPTOR WITH PORTS TO REMAIN EASILY ACCESSIBLE FOR UTILITY INSPECTION AND SAMPLING.
4. THE INTERCEPTOR AND CLEAN-OUTS PORT SHALL BE LOCATED OUTSIDE AND IN NON-TRAFFIC AREA WHENEVER POSSIBLE. IF INSTALLED IN A TRAFFIC AREA MINI-MANHOLES ARE REQUIRED ON THE INSPECTION PORTS (CLEAN OUTS). THE SURFACE SURROUNDING THE INTERCEPTOR SHALL BE SLOPED TO DRAIN STORM WATER AWAY FROM THE INTERCEPTOR.
5. THE CAPACITY DETERMINATION FOR THE INTERCEPTOR IS THE RESPONSIBILITY OF THE OWNER/CUSTOMER. THE MINIMUM VOLUME OF ANY GREASE INTERCEPTOR SHALL BE 750 GALLONS AND THE MAXIMUM VOLUME OF A SINGLE GREASE INTERCEPTOR SHALL BE 1250 GALLONS. WHEN THE REQUIRED EFFECTIVE CAPACITY OF THE GREASE INTERCEPTOR IS GREATER THAN 1250 GALLONS, INSTALLATION OF MULTIPLE GREASE INTERCEPTORS IN SERIES IS REQUIRED.
6. NO BAFFLE IS REQUIRED IF THERE ARE MULTIPLE GREASE INTERCEPTORS INSTALLED IN SERIES. HOWEVER, CLEANOUT PORTS MUST BE INSTALLED ON EACH END OF EACH INTERCEPTOR.
7. THE PROPERTY OWNER/CUSTOMER SHALL BE RESPONSIBLE FOR THE OPERATION AND MAINTENANCE OF THE INTERCEPTOR.
8. THE GREASE INTERCEPTOR SHALL NOT BE USED FOR THE PURPOSE OF INTERCEPTING SAND AND OIL FROM NON- FOOD HANDLING ESTABLISHMENTS.
9. EACH FACILITY WITH AN OIL/GREASE INTERCEPTOR SHALL HAVE A SEPARATE (NOT SHARED) INTERCEPTOR AND SHALL BE INDIVIDUALLY METERED THROUGH THE DEPARTMENT.
10. A "GREASE TRAP" OR "OIL/GREASE INTERCEPTOR" SHALL BE REQUIRED TO RECEIVE THE DRAINAGE FROM FIXTURES AND EQUIPMENT (SINKS, DISHWASHERS, FLOOR DRAINS, CAN WASH AREAS, ETC.) WITH GREASE LADEN WASTE LOCATED IN COMMERCIAL FOOD PREPARATION AREAS SUCH AS RESTAURANTS, HOTEL KITCHENS, HOSPITALS, SCHOOL KITCHENS, BARS, FACTORY CAFETERIAS, CLUBS, ETC.
11. THE "GREASE TRAP" OR "OIL/GREASE INTERCEPTOR" SHALL BE LOCATED AS CLOSE AS PRACTICALLY POSSIBLE TO THE FIXTURES AND EQUIPMENT GENERATING GREASE.
12. A "SOLIDS INTERCEPTOR" SHALL BE CONSIDERED TO BE INSTALLED UPSTREAM OF A " GREASE TRAP" WHERE SUBSTANTIAL AMOUNT OF SOLIDS FROM FOOD GRINDERS, DISPOSALS MAY BE PRESENT.
13. MANHOLE COVER SHALL BE MACHINED TO ACCEPT INFLOW PROTECTOR.
14. SEE WUD STANDARD DETAIL 1SB FOR FIBERGLASS TYPE OIL/GREASE INTERCEPTOR INSTALLATIONS.\*

PALM BEACH COUNTY CONSTRUCTION STANDARDS & DETAILS

REVISION/ISSUE DATE  
01/2023\*

OIL/GREASE INTERCEPTOR  
CONCRETE STRUCTURE\*

PAGE NO.  
1 SA\*

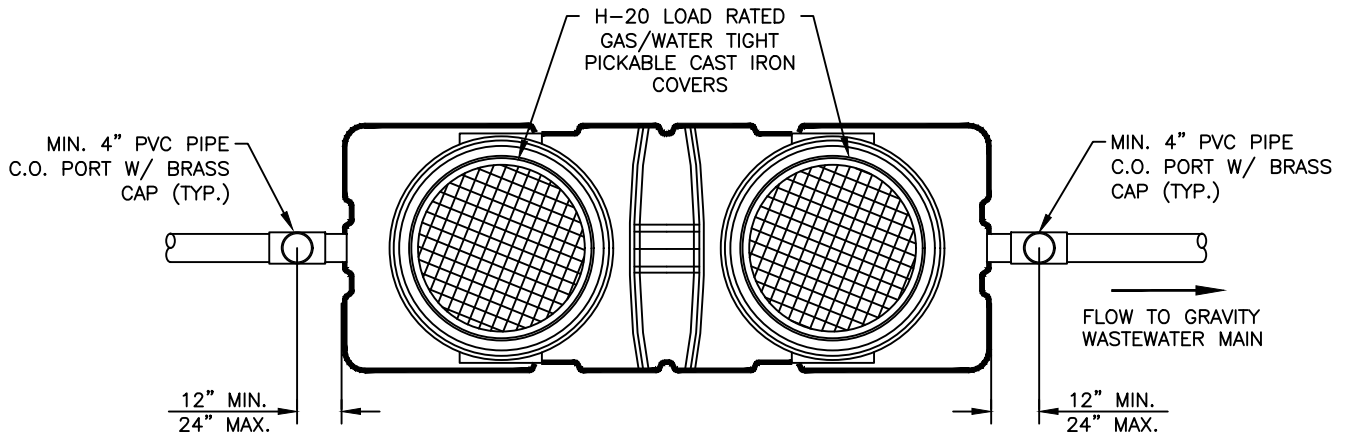

**TOP VIEW**

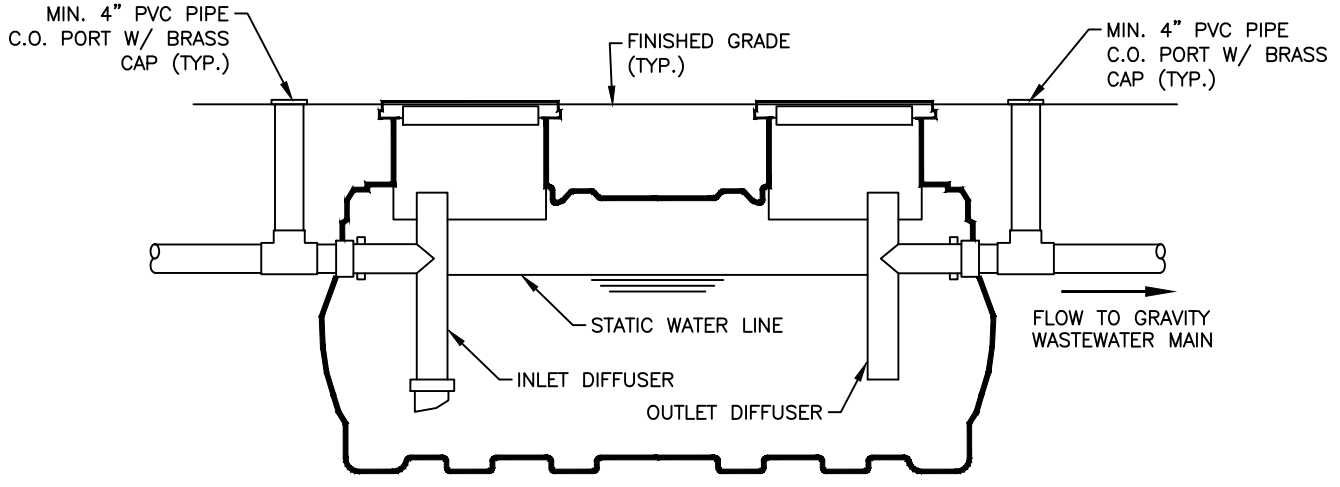

**SECTION A-A**

**NOTES:**

1. INSPECTION PORTS (CLEANOUTS) ARE REQUIRED TO BE INSTALLED AT EACH END OF ANY TYPE OF INTERCEPTOR WITH PORTS TO REMAIN ACCESSIBLE TO FOR UTILITY INSPECTION AND SAMPLING.
2. THE INTERCEPTOR PORTS (CLEANOUTS) SHALL BE LOCATED OUTSIDE AND IN A NON-TRAFFIC AREA WHEREVER POSSIBLE. IF INSTALLED IN A TRAFFIC AREA, MINI-MANHOLES ARE REQUIRED TO BE INSTALLED ON ALL PORTS (CLEANOUTS). THE SURFACE SURROUNDING THE INTERCEPTOR SHALL BE SLOPED TO DRAIN STORM WATER AWAY FROM THE INTERCEPTOR.
3. IF AN INTERCEPTOR NEEDS TO BE INSTALLED IN DOORS DUE TO EXISTING SITE CONDITIONS, PRIOR DEPARTMENT APPROVAL IS REQUIRED WITH IN DOOR INSTALLATIONS APPROVED ON A CASE BY CASE BASIS.
4. THE PROPERTY OWNER/CUSTOMER SHALL BE RESPONSIBLE FOR THE OPERATION AND MAINTENANCE OF THE INTERCEPTOR.
5. EACH FACILITY WITH AN OIL/GREASE INTERCEPTOR SHALL HAVE A DEDICATED (NOT SHARED) INTERCEPTOR WITH THEIR POTABLE WATER SERVICE INDIVIDUALLY METERED THROUGH THE DEPARTMENT.
6. SEE WUD STANDARD DETAIL 1SA FOR CONCRETE STRUCTURE TYPE OIL/GREASE INTERCEPTOR INSTALLATIONS.

REVISION/ISSUE DATE  
01/2023\*

OIL/GREASE INTERCEPTOR  
POLYETHEYLENE/FIBERGLASS STRUCTURE DETAIL\*

PAGE NO.  
1 SB\*

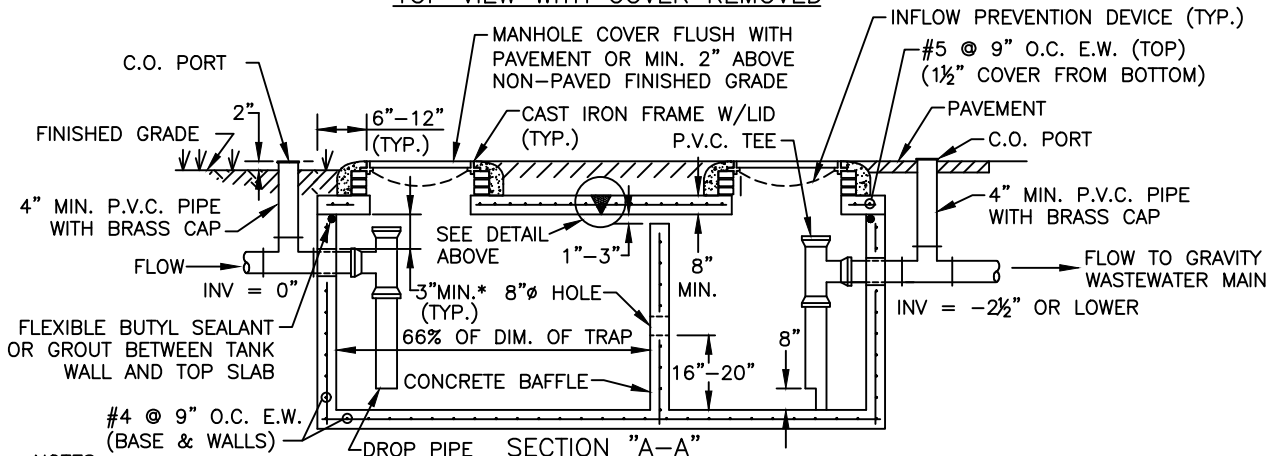
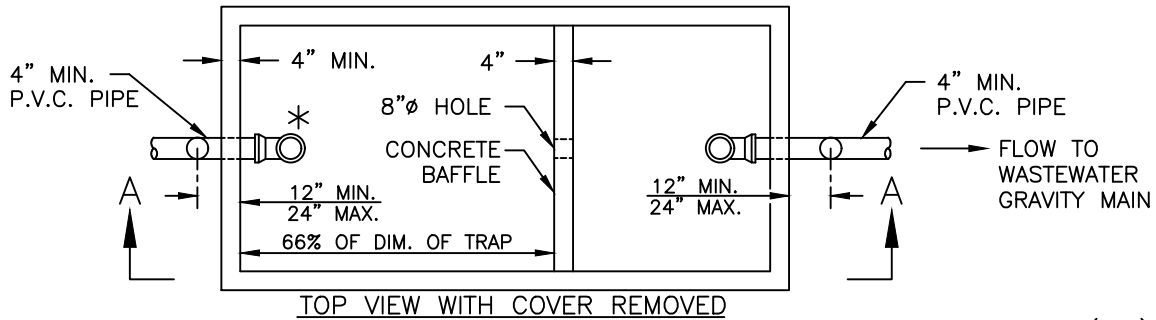
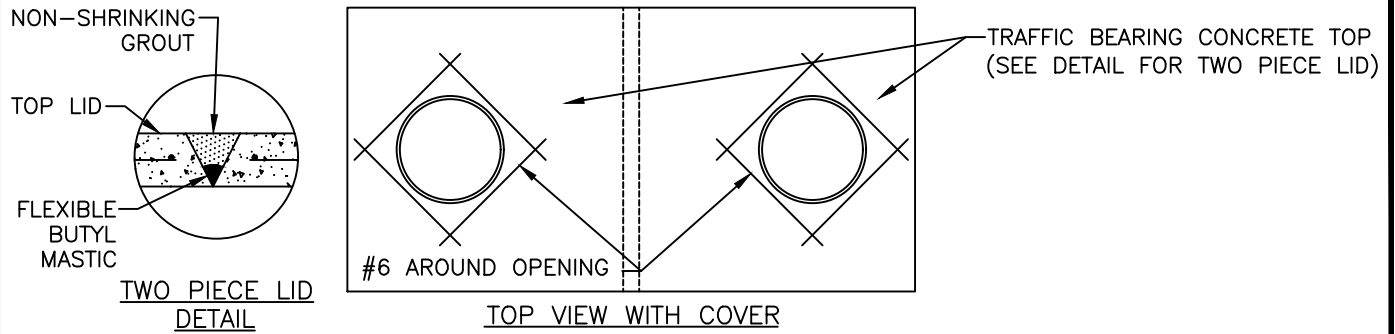

**NOTES:**

- SAND/OIL INTERCEPTORS SHALL BE WATERTIGHT AND SHALL BE BUILT OF PRECAST CONCRETE WHICH HAS A DESIGN COMPRESSIVE STRENGTH OF MINIMUM 3000 PSI AFTER 28 DAYS CURE. THE DESIGN, SIZING AND CONSTRUCTION MUST CONFORM TO THIS STANDARD AND TO ALL APPLICABLE BUILDING CODES, HEALTH DEPARTMENT REQUIREMENTS AND REGULATIONS, INCLUDING, BUT NOT LIMITED TO CHAPTER 64E-6, FLORIDA ADMINISTRATIVE CODE. WALL AND SLAB THICKNESS SHOWN ARE MINIMUMS, AND SHALL BE DETERMINED BY THE OWNER'S ENGINEER. THE CONCRETE BOX SHALL BE MONOLITHIC POURED AND SHALL HAVE A PRECAST HOLE ON EACH END ONLY FOR LATERAL. THE PRECAST HOLES SHALL HAVE CAST-IN BOOTS WHENEVER POSSIBLE.
- AN ALTERNATIVE TYPE OF INTERCEPTOR STRUCTURE MAY BE INSTALLED ONLY WITH PRIOR DEPARTMENT APPROVAL. SHOP DRAWINGS ARE REQUIRED TO BE SUBMITTED AND APPROVED BY THE DEPARTMENT PRIOR TO THE PRE-CONSTRUCTION MEETING FOR ALL INTERCEPTORS.
- INSPECTION PORTS (CLEAN OUTS) ARE REQUIRED TO BE INSTALLED AT EACH END OF ANY TYPE OF INTERCEPTOR WITH PORTS TO REMAIN EASILY ACCESSIBLE FOR UTILITY INSPECTION AND SAMPLING.
- THE INTERCEPTOR SHALL BE LOCATED IN GRASS AREA/NON-TRAFFIC AREA WHENEVER POSSIBLE. THE SURFACE SURROUNDING THE INTERCEPTOR SHALL BE SLOPED TO DRAIN STORM WATER AWAY FROM THE INTERCEPTOR.
- THE CAPACITY DETERMINATION FOR THE INTERCEPTOR IS THE RESPONSIBILITY OF THE OWNER/CUSTOMER. THE MINIMUM VOLUME OF A SAND/OIL INTERCEPTOR SHALL BE 750 GALLONS. WHEN THE REQUIRED EFFECTIVE CAPACITY OF THE SAND/OIL INTERCEPTOR IS GREATER THAN 750 GALLONS, INSTALLATION OF SINGLE COMPARTMENT SAND/OIL INTERCEPTORS IN SERIES IS REQUIRED.
- THE PROPERTY OWNER/CUSTOMER SHALL BE RESPONSIBLE FOR THE OPERATION AND MAINTENANCE OF THE INTERCEPTOR.
- SAND/OIL INTERCEPTOR SHALL NOT BE USED FOR THE PURPOSE OF INTERCEPTION OF GREASE FROM FOOD HANDLING ESTABLISHMENTS.
- EACH FACILITY REQUIRED TO HAVE A SAND/OIL INTERCEPTOR SHALL HAVE A SEPERATE INTERCEPTOR AND SHALL BE INDIVIDUALLY METERED THROUGH THE DEPARTMENT.
- MANHOLE LIDS SHALL BE MACHINED TO ACCEPT INFLOW PREVENTER.
- SEE WUD STANDARD DETAIL 2AS FOR FIBERGLASS TYPE SAND/OIL INTERCEPTOR INSTALLATIONS.\*

PALM BEACH COUNTY CONSTRUCTION STANDARDS & DETAILS

REVISION/ISSUE DATE

01/2023\*

SAND/OIL INTERCEPTOR  
CONCRETE STRUCTURE \*

PAGE NO.

2SA\*

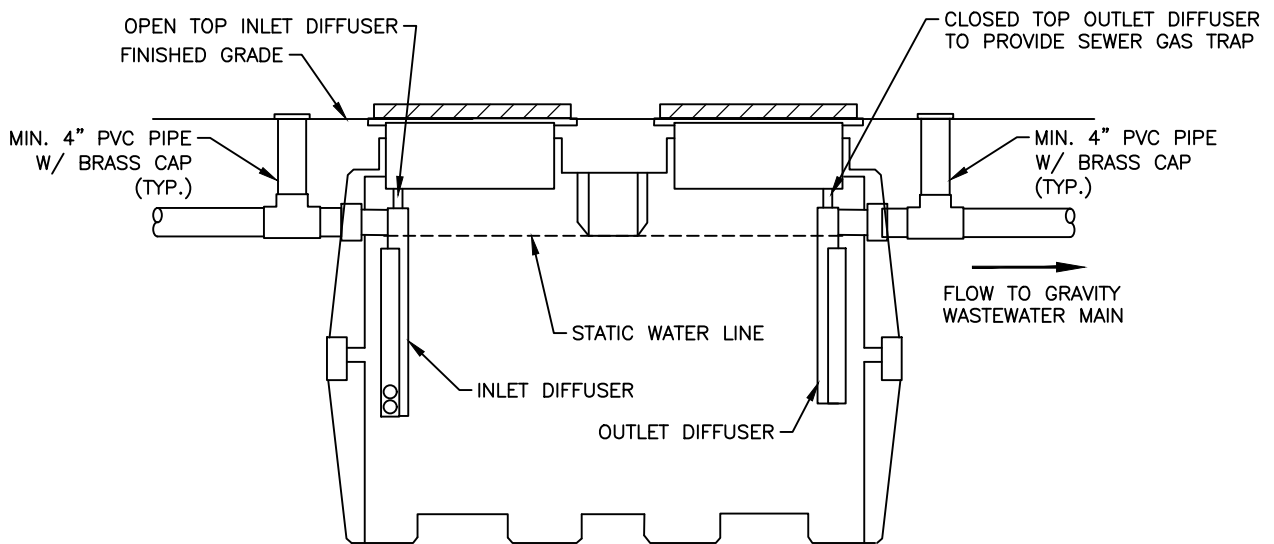
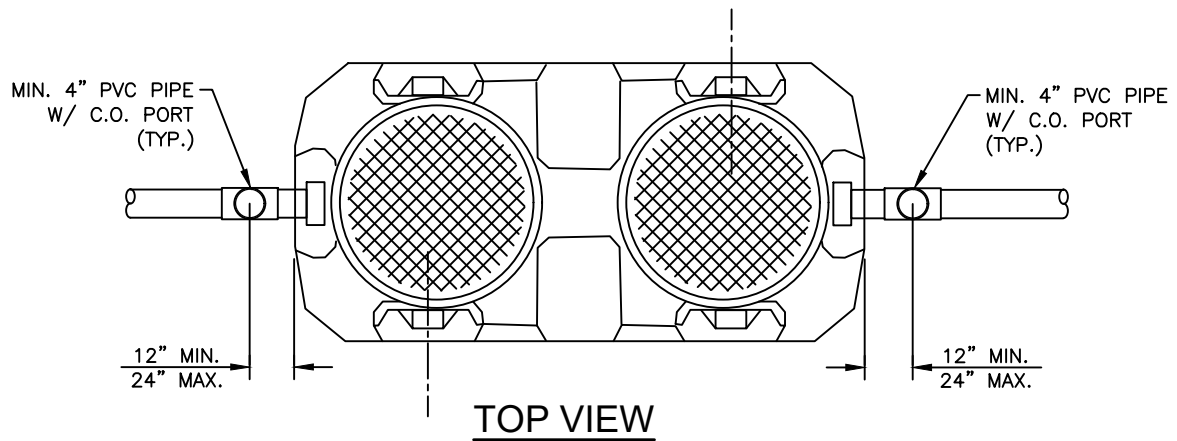

**SECTION A-A**

**NOTES:**

1. INSPECTION PORTS (CLEANOUTS) ARE REQUIRED TO BE INSTALLED AT EACH END OF ANY TYPE OF INTERCEPTOR WITH PORTS TO REMAIN ACCESSIBLE TO FOR UTILITY INSPECTION AND SAMPLING.
2. THE INTERCEPTOR PORTS (CLEANOUTS) SHALL BE LOCATED OUTSIDE AND IN A NON-TRAFFIC AREA WHEREVER POSSIBLE. IF INSTALLED IN A TRAFFIC AREA, MINI-MANHOLES ARE REQUIRED TO BE INSTALLED ON ALL PORTS (CLEANOUTS). THE SURFACE SURROUNDING THE INTERCEPTOR SHALL BE SLOPED TO DRAIN STORM WATER AWAY FROM THE INTERCEPTOR.
3. IF AN INTERCEPTOR NEEDS TO BE INSTALLED IN DOORS DUE TO EXISTING SITE CONDITIONS, PRIOR DEPARTMENT APPROVAL IS REQUIRED WITH IN DOOR INSTALLATIONS APPROVED ON A CASE BY CASE BASIS.
4. THE PROPERTY OWNER/CUSTOMER SHALL BE RESPONSIBLE FOR THE OPERATION AND MAINTENANCE OF THE INTERCEPTOR.
5. EACH FACILITY WITH AN SAND/OIL INTERCEPTOR SHALL HAVE A DEDICATED (NOT SHARED) INTERCEPTOR WITH THEIR POTABLE WATER SERVICE INDIVIDUALLY METERED THROUGH THE DEPARTMENT.
6. SEE WUD STANDARD DETAIL 2SA FOR CONCRETE STRUCTURE TYPE SAND/OIL INTERCEPTOR INSTALLATIONS.

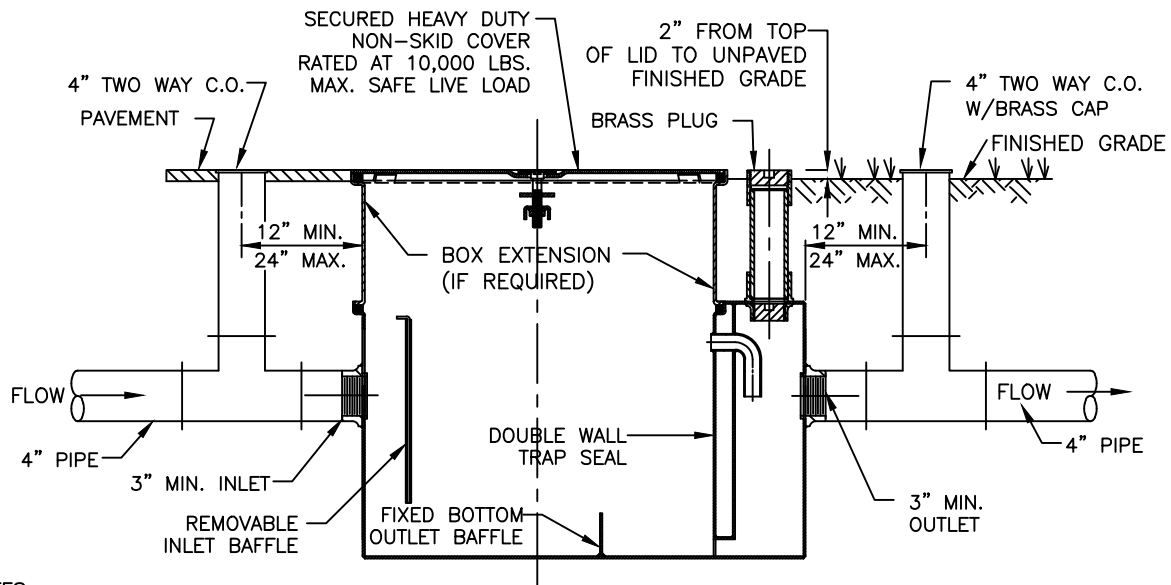

**NOTES:**

1. THE GREASE TRAP SHALL BE WATERTIGHT AND GAS TIGHT AND SHALL BE FABRICATED FROM STEEL, ACID RESISTANT COATED INTERIOR AND EXTERIOR.
2. THE GREASE TRAP SHALL BE CERTIFIED AND TAGGED BY THE SEAL OF THE PLUMBING AND DRAINAGE INSTITUTE (PDI), AND PDI RATED AT 50 GPM FLOW RATE AND 100 LBS. GREASE CAPACITY. THE GREASE TRAP SIZE, DESIGN AND INSTALLATION MUST COMPLY OR EXCEED THE APPLICABLE BUILDING CODES AND REGULATIONS.
3. THE GREASE TRAP MAY BE USED IF AN OIL/GREASE INTERCEPTOR IS NOT REQUIRED AND ONLY FOR APPLICATIONS UP TO 25 GPM FLOW RATE (ONE MINUTE FLOW) OR 50 GPM (TWO MINUTE FLOW), DETERMINED USING THE PDI G 101 STANDARD. FOR HIGHER FLOW RATES OR GREASE CAPACITY GREATER THAN 50 LBS., AN APPROVED "OIL/GREASE INTERCEPTOR" WILL BE REQUIRED. A DESIGN CALCULATION SHALL BE SUBMITTED FOR APPROVAL WITH A SHOP DRAWING PRIOR TO PRE-CONSTRUCTION MEETING. THE SHOP DRAWING SHALL BE SIGNED BY THE DESIGNING ENGINEER AND BY THE CONTRACTOR. THE PROJECT NAME WITH STREET ADDRESS OF THE FACILITY (IF AVAILABLE) SHALL BE SHOWN ON THE SHOP DRAWING. OTHER DESIGNS MAY BE USED UPON APPROVAL OF SHOP DRAWINGS.
4. THE GREASE TRAP SHALL BE LOCATED OUTDOORS, EASY ACCESSIBLE FOR MAINTENANCE AND SAMPLING, PREFERABLY IN GRASS AREA, NOT IN TRAFFIC AREA, PARKING SPACES OR SIDEWALKS. THE SURFACE SURROUNDING THE GREASE TRAP SHALL BE SLOPED TO DRAIN STORM WATER AWAY FROM THE GREASE TRAP.
5. THE GREASE TRAP SHALL NOT BE USED FOR THE PURPOSE OF INTERCEPTING SAND AND OIL FROM NON-FOOD HANDLING ESTABLISHMENTS.
6. THE PROPERTY OWNER/CUSTOMER SHALL BE RESPONSIBLE FOR THE OPERATION AND MAINTENANCE OF THE GREASE TRAP.
7. EACH FACILITY WITH A GREASE TRAP SHALL BE INDIVIDUALLY METERED THROUGH THE DEPARTMENT.
8. EACH FACILITY WHICH IS REQUIRED TO INSTALL A GREASE TRAP SHALL HAVE A SEPARATE (NOT SHARED) GREASE TRAP.
9. INSPECTION PORTS (CLEAN OUTS) ARE REQUIRED TO BE INSTALLED AT EACH END OF ANY TYPE OF INTERCEPTOR WITH PORTS TO REMAIN EASILY ACCESSIBLE FOR UTILITY INSPECTION AND SAMPLING.
10. A "GREASE TRAP" OR "OIL/GREASE INTERCEPTOR" SHALL BE REQUIRED TO RECEIVE THE DRAINAGE FROM FIXTURES AND EQUIPMENT (SINKS, DISHWASHERS, FLOOR DRAINS, CAN WASH AREAS, ETC.) WITH GREASE LADEN WASTE LOCATED IN COMMERCIAL FOOD PREPARATION AREAS SUCH AS RESTAURANTS, HOTEL KITCHENS, HOSPITALS, SCHOOL KITCHENS, BARS, FACTORY CAFETERIAS, CLUBS, ETC.
11. THE "GREASE TRAP" OR "OIL/GREASE INTERCEPTOR" SHALL BE LOCATED AS CLOSE PRACTICALLY POSSIBLE TO THE FIXTURES AND EQUIPMENT GENERATING GREASE.
12. GREASE TRAPS SHALL BE EQUIPPED WITH DEVICES TO CONTROL THE RATE OF FLOW, SO THE RATE OF THE FLOW DO NOT EXCEED 25 GPM. THE FLOW CONTROL DEVICE SHALL BE INSTALLED IN ACCORDANCE WITH THE CODE AND MANUFACTURER'S INSTRUCTIONS.
13. A "SOLIDS INTERCEPTOR" SHALL BE CONSIDERED TO BE INSTALLED UPSTREAM OF A " GREASE TRAP" WHERE SUBSTANTIAL AMOUNT OF SOLIDS FROM FOOD GRINDERS, DISPOSALS MAY BE PRESENT.

PALM BEACH COUNTY CONSTRUCTION STANDARDS & DETAILS

REVISION/ISSUE DATE

6/2019

GREASE TRAP

PAGE NO.

35

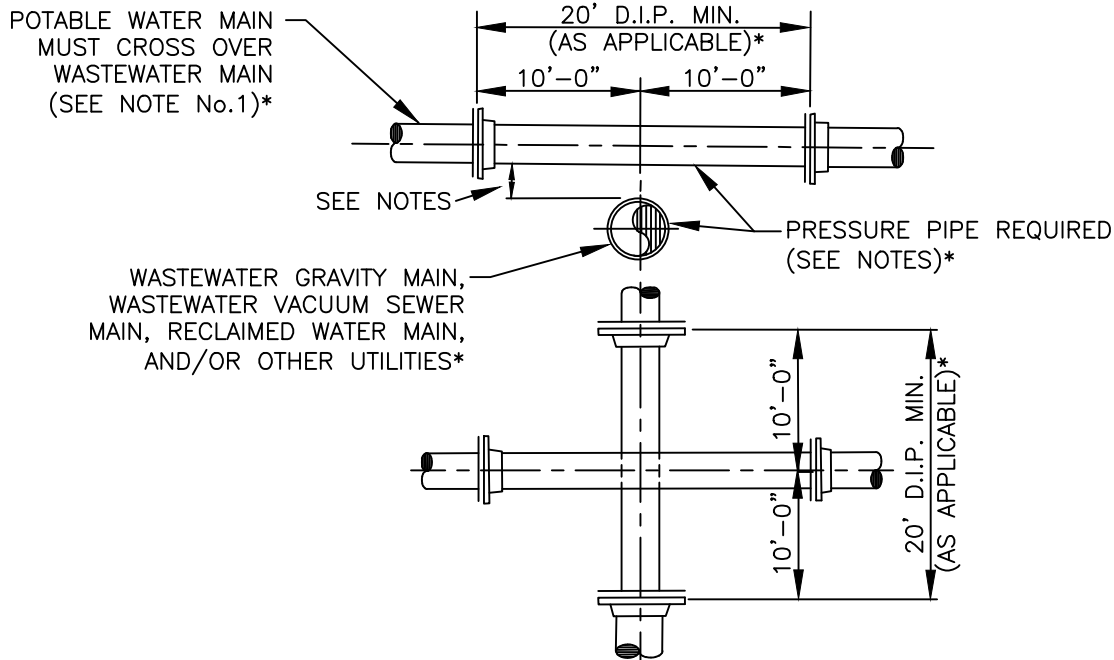

**NOTES:**

1. WHEN A WASTEWATER FORCE MAIN CROSSES OVER AND/OR UNDER A STORM SEWER, GRAVITY WASTEWATER, VACUUM GRAVITY WASTEWATER, AND/OR RECLAIMED WATER MAIN THE WASTEWATER FORCE MAIN SHALL BE LAID TO PROVIDE A MINIMUM TWELVE (12) INCH VERTICAL SEPARATION BETWEEN THE BOTTOM OF THE UPPER PIPE AND THE CROWN OF THE LOWER PIPE. WHEN THE MINIMUM TWELVE (12) INCH VERTICAL SEPARATION CANNOT BE OBTAINED A MINIMUM SIX (6) INCH VERTICAL SEPARATION IS PERMITTED PROVIDED THAT A TWENTY (20) FOOT SECTION OF WASTEWATER DUCTILE IRON PIPE MAIN IS CENTERED ON THE CROSSING WITH THE OTHER PIPE HAVING A TWENTY (20) FOOT SECTION CENTERED ON THE CROSSING AND WITH PRIOR DEPARTMENT APPROVAL. A WASTEWATER FORCE MAIN MUST CROSS UNDER ANY POTABLE WATER MAIN WITH A MINIMUM TWELVE (12) INCH VERTICAL SEPARATION REQUIRED. WHEN THE MINIMUM TWELVE (12) INCH VERTICAL SEPARATION CANNOT BE OBTAINED A MINIMUM SIX (6) INCH VERTICAL SEPARATION IS PERMITTED PROVIDED THAT A TWENTY (20) FOOT SECTION OF POTABLE WATER DUCTILE IRON PIPE MAIN IS CENTERED ON THE CROSSING WITH THE WASTEWATER FORCE MAIN HAVING A TWENTY (20) FOOT SECTION CENTERED ON THE CROSSING AND ONLY WITH PRIOR DEPARTMENT APPROVAL. A WASTEWATER FORCE MAIN MAY CROSS OVER A POTABLE WATER MAIN ON A CASE BY CASE BASIS PROVIDED A MINIMUM TWELVE (12) INCH VERTICAL SEPARATION IS OBTAINED BETWEEN THE BOTTOM OF THE UPPER PIPE AND THE CROWN OF THE LOWER PIPE AND ONLY WITH PRIOR DEPARTMENT APPROVAL.\*
2. TEN (10) FOOT MINIMUM HORIZONTAL SEPARATION (OUTSIDE WALL TO OUTSIDE WALL) IS REQUIRED BETWEEN A WASTEWATER MAIN AND POTABLE WATER MAIN, A STORM SEWER, AND/OR RECLAIMED WATER MAIN. A SIX (6) FOOT MINIMUM HORIZONTAL SEPARATION (OUTSIDE WALL TO OUTSIDE WALL) IS ACCEPTABLE WITH PRIOR DEPARTMENT APPROVAL BEFORE THE INSTALLATION OF THE WASTEWATER MAIN. A THREE (3) FOOT MINIMUM HORIZONTAL SEPARATION (OUTSIDE WALL TO OUTSIDE WALL) BETWEEN A WASTEWATER MAIN AND A RECLAIMED WATER MAIN IS ACCEPTABLE WITH PRIOR DEPARTMENT APPROVAL BEFORE THE INSTALLATION OF THE WASTEWATER MAIN.\*
3. WHEN A WASTEWATER MAIN CROSSES ANY ELECTRICAL CONDUIT(S), COMMUNICATION CONDUIT(S), AND/OR GAS MAIN, A MINIMUM OF EIGHTEEN (18) INCH VERTICAL SEPARATION IS REQUIRED BETWEEN THE BOTTOM OF THE UPPER PIPE AND THE CROWN OF THE LOWER PIPE. A WASTEWATER PIPE SHALL ALWAYS CROSS OVER THE OTHER UTILITY MAINS UNLESS APPROVED BY THE DEPARTMENT BEFORE THE INSTALLATION OF THE WASTEWATER MAIN. WHEN THE WASTEWATER MAIN IS D.I.P. AND THE GAS MAIN IS STEEL PIPE, THE WASTEWATER MAIN SHALL BE POLY-WRAPPED PER DEPARTMENT STANDARDS.
4. WASTEWATER LATERALS SHALL CROSS UNDER POTABLE WATER MAINS WITH A MINIMUM TWELVE (12) INCH VERTICAL SEPARATION BETWEEN THE BOTTOM OF THE UPPER PIPE AND THE CROWN OF THE LOWER PIPE. WHEN THE MINIMUM TWELVE (12) INCH VERTICAL SEPARATION CANNOT BE OBTAINED A MINIMUM SIX (6) INCH VERTICAL SEPARATION IS PERMITTED PROVIDED THAT A TWENTY (20) FOOT SECTION OF POTABLE WATER DUCTILE IRON PIPE MAIN IS CENTERED OVER THE WASTEWATER LATERAL AND THE LATERAL IS PVC C-900 PIPE. WHEN A WASTEWATER LATERAL MUST CROSS OVER A POTABLE WATER MAIN A MINIMUM TWELVE (12) INCH VERTICAL SEPARATION IS REQUIRED WITH THE LATERAL MAIN BEING PVC C-900 PIPE AND THE POTABLE WATER MAIN HAVING A TWENTY (20) FOOT SECTION OF POTABLE WATER DUCTILE IRON PIPE MAIN CENTERED ON CROSSING.\*
5. WASTEWATER MAINS SHALL ALWAYS CROSS UNDER POTABLE WATER SERVICE LINES WITH A MINIMUM TWELVE (12) INCH VERTICAL SEPARATION BETWEEN THE BOTTOM OF THE UPPER PIPE AND THE CROWN OF THE LOWER PIPE. IF THE MINIMUM TWELVE (12) INCH VERTICAL SEPARATION CANNOT BE MAINTAINED THE WATER SERVICE LINE SHALL BE ENCASED IN A TEN (10) FOOT MINIMUM LONG CASING CENTERED OVER THE CROSSING WITH SIX (6) INCH MINIMUM VERTICAL SEPARATION.\*
6. WASTEWATER MAINS SHALL CROSS PERPENDICULAR TO ALL POTABLE WATER MAINS, STORM MAINS, STORM SEWER MAINS, RECLAIMED WATER MAINS, AND/OR OTHER UTILITIES WHENEVER POSSIBLE.\*

PALM BEACH COUNTY CONSTRUCTION STANDARDS & DETAILS

REVISION/ISSUE DATE

01/2023\*

WASTEWATER MAIN CROSSING OTHER MAINS AND UTILITIES\*

PAGE NO.

4S

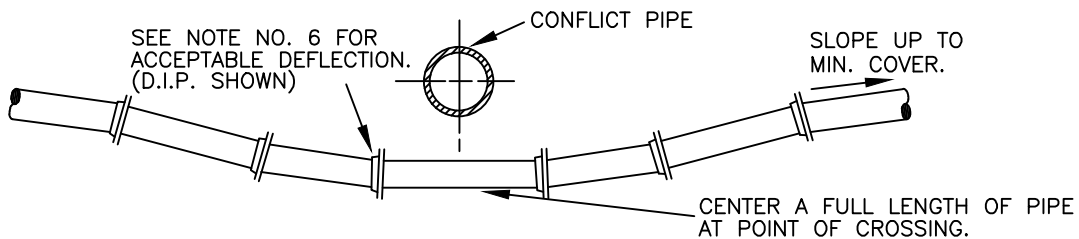
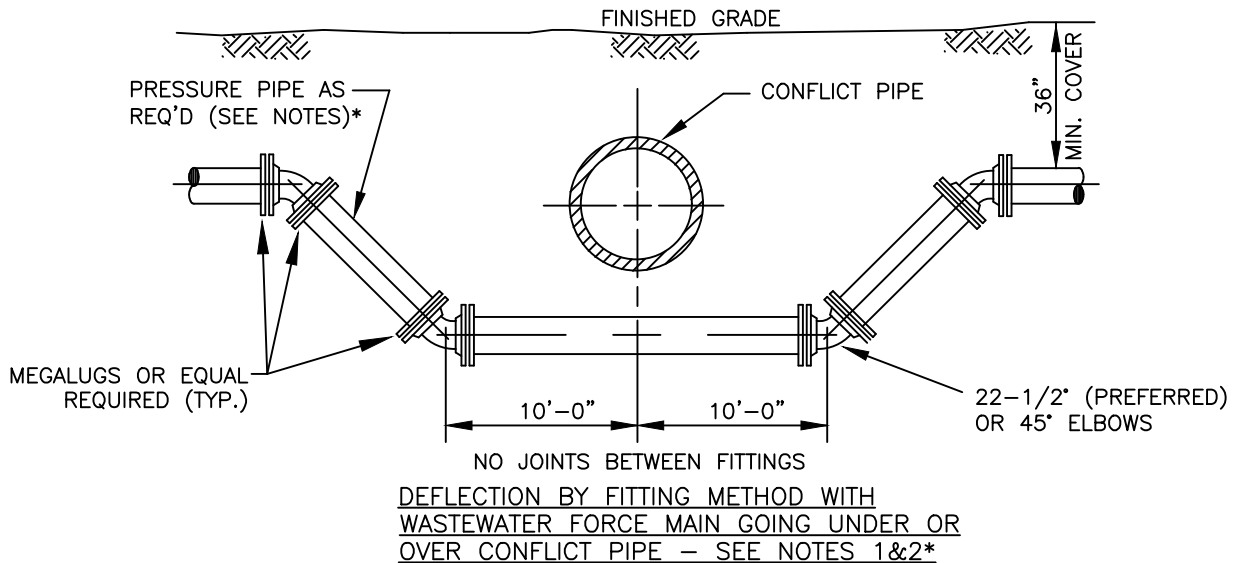

**NOTES:**

1. DEFLECTION BY FITTINGS AND/OR PIPE JOINT METHODS APPLIES TO WASTEWATER FORCE MAIN CROSSING OVER OR UNDER CONFLICT PIPE WITH CROSSING OVER CONFLICT PIPE PREFERRED. WHEN A WASTEWATER FORCE MAIN CROSSES OVER A STORM SEWER, GRAVITY WASTEWATER, VACUUM GRAVITY AND/OR RECLAIMED WATER MAIN THE WASTEWATER FORCE MAIN SHALL BE LAID TO PROVIDE A MINIMUM TWELVE (12) INCH VERTICAL SEPARATION BETWEEN THE BOTTOM OF THE UPPER PIPE AND THE CROWN OF THE LOWER PIPE. WHEN THE MINIMUM OF TWELVE (12) INCH VERTICAL SEPARATION CANNOT BE OBTAINED A MINIMUM SIX (6) INCH VERTICAL SEPARATION IS PERMITTED PROVIDED THAT A TWENTY (20) FOOT SECTION OF WASTEWATER DUCTILE IRON PIPE FORCE MAIN IS CENTERED ON THE CROSSING WITH THE LOWER PIPE HAVING A TWENTY (20) FOOT SECTION CENTERED ON THE CROSSING. A WASTEWATER FORCE MAIN MUST CROSS UNDER ANY POTABLE WATER MAIN WITH A MINIMUM TWELVE (12) INCH VERTICAL SEPARATION REQUIRED. WHEN THE MINIMUM TWELVE (12) INCH VERTICAL SEPARATION CANNOT BE OBTAINED A MINIMUM SIX (6) INCH VERTICAL SEPARATION IS PERMITTED PROVIDED THAT A TWENTY (20) FOOT DUCTILE IRON PIPE SECTION OF POTABLE WATER MAIN IS CENTERED ON THE CROSSING WITH THE WASTEWATER FORCE MAIN HAVING A TWENTY (20) FOOT DUCTILE IRON PIPE SECTION CENTERED ON THE CROSSING. A WASTEWATER FORCE MAIN MAY CROSS OVER A POTABLE WATER MAIN ON A CASE BY CASE BASIS PROVIDED A MINIMUM OF TWELVE (12) INCH VERTICAL SEPARATION IS OBTAINED BETWEEN THE BOTTOM OF THE UPPER PIPE AND THE CROWN OF THE LOWER PIPE AND ONLY WITH PRIOR DEPARTMENT APPROVAL.\*
2. THE PREFERRED PIPE DEFLECTION METHOD IS BY USING MECHANICAL RESTRAINT FITTINGS.\*
3. WASTEWATER FORCE MAIN DEFLECTION BY PIPE JOINT METHOD REQUIRES DEPARTMENT APPROVAL PRIOR TO THE INSTALLATION OF THE FORCE MAIN.\*
4. DEFLECTION BY PIPE JOINT SHALL NOT EXCEED SEVENTY-FIVE PERCENT (75%) OF MANUFACTURER'S RECOMMENDED MAXIMUM JOINT DEFLECTION FOR DUCTILE IRON PIPE AND PVC PIPE DEFLECTION CAN ONLY BE ALLOWED BY INSTALLING THE APPROPRIATE FITTINGS – NO EXCEPTIONS.\*

PALM BEACH COUNTY CONSTRUCTION STANDARDS & DETAILS

REVISION/ISSUE DATE

01/2023\*

WASTEWATER MAIN CONFLICT  
DEFLECTION DETAIL\*

PAGE NO.

55

**CONSTRUCTION PROCEDURES**

THE BACKFILL FOR THE FIRST AND SECOND STAGES SHALL BE PLACED IN 6" LAYERS (COMPACTED THICKNESS) AND SHALL BE COMPACTED TO 100% OF MAXIMUM DENSITY AS DETERMINED BY AASHTO T-99.

**STAGE 1:**

THE CONTRACTOR SHALL PROVIDE ADEQUATE COMPACTED FILL BENEATH THE HAUNCHES OF THE PIPE, USING MECHANICAL TAMPS SUITABLE FOR THIS PURPOSE. THIS COMPACTION APPLIES TO THE MATERIAL PLACED BENEATH THE HAUNCHES OF THE PIPE AND ABOVE ANY BEDDING REQUIRED.

**STAGE 2:**

THE CONTRACTOR SHALL OBTAIN A WELL-COMPACTED BED AND FILL ALONG THE SIDES OF THE PIPE AND TO A POINT INDICATING THE TOP OF SUB-GRADE MATERIAL.

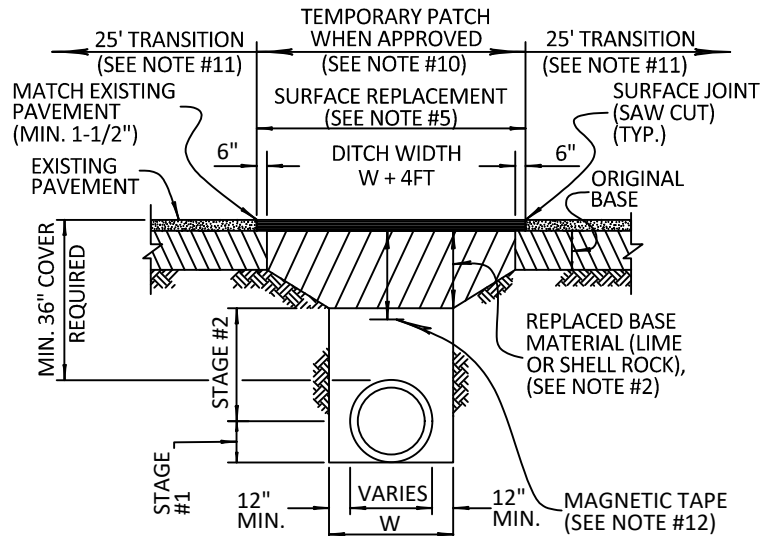

**REPLACEMENT OF FLEXIBLE PAVEMENT FOR PERMITTED PAVEMENT CUT**

**NOTES**

- 1) BEDDING SHALL CONSIST OF IN-SITU GRANULAR MATERIAL OR WASHED AND GRADED LIMEROCK 3/8" - 7/8" SIZING WITH EQUAL OR GREATER STRUCTURAL ADEQUACY AS EXISTING. UNSUITABLE IN-SITU MATERIALS SUCH AS MUCK, DEBRIS AND LARGER ROCKS SHALL BE REMOVED.
- 2) REPLACED BASE MATERIAL (PER LAND DEVELOPMENT DESIGN STANDARDS) OVER DITCH SHALL BE TWICE THE THICKNESS OF THE ORIGINAL BASE AND MATCH THE TYPE OF MATERIAL OF THE ORIGINAL BASE OR 12" MINIMUM, WHICHEVER IS GREATER.
- 3) ASPHALT CONCRETE PAVEMENT JOINTS SHALL BE MECHANICALLY SAWED AND BUTT-JOINED.
- 4) BASE MATERIAL SHALL BE PLACED IN TWO OR THREE LAYERS (6" MAX. PER LAYER) AND EACH LAYER THOROUGHLY ROLLED OR TAMPED TO THE SPECIFIED DENSITY (MINIMUM 98% AASHTO - T-180)
- 5) SURFACE MATERIAL WILL BE CONSISTENT WITH THE EXISTING SURFACE OR 1-1/2" SP 12.5 STRUCTURAL COURSE (TRAFFIC LEVEL A) ASPHALTIC CONCRETE WITH RC-70 PRIME COAT AT 0.10 GAL/SQ. YD. FOR LIMEROCK BASE AND TACK COAT AT 0.05 GAL/SY FOLLOW THE LATEST FDOT SPECIFICATIONS FOR APPLICATION RATES OF PRIME AND TACK COATS, CONTRACTOR TO SUBMIT MATERIALS AND RATES TO ENGINEER FOR APPROVAL PRIOR TO BEGINNING WORK.
- 6) PIPE SHALL BE PLACED IN A DRY TRENCH.
- 7) ALL ROADWAY REPAIR WORK SHALL BE PERFORMED IN CONFORMANCE WITH APPLICABLE FDOT STANDARD SPECIFICATIONS FOR ROAD AND BRIDGE CONSTRUCTION AND COUNTY PPM# EL-0-3606.
- 8) DENSITY TESTS SHALL BE TAKEN IN 1 FT. LIFTS ABOVE THE PIPE AT INTERVALS OF 400 FT MAXIMUM (1 SET MINIMUM) OR AS DIRECTED BY THE CONSTRUCTION COORDINATION DIVISION. RESULTS SHALL BE SUBMITTED TO CONSTRUCTION COORDINATION DIVISION AS PART OF THEIR FIELD REVIEW.
- 9) ENGINEER-OF-RECORD SHALL PROVIDE FULL-TIME INSPECTION DURING THE ENTIRETY OF THE OPEN-CUT OPERATION, BEGINNING WITH THE EXCAVATION AND CONTINUING THROUGH THE COMPLETION OF THE PAVING.
- 10) IF THE PAVEMENT IS NOT COMPLETELY RESTORED IMMEDIATELY FOLLOWING THE OPEN CUT, A SMOOTH TEMPORARY PATCH (MINIMUM 1.5" SP 12.5 STRUCTURAL COURSE ASPHALT) SHALL BE INSTALLED PROPERLY MATCHING THE EXISTING GRADING OF THE ROADWAY. THE TEMPORARY PATCH SHALL BE ALLOWED TO REMAIN IN PLACE AND BE MAINTAINED FOR A PERIOD NO LONGER THAN 45 DAYS. THE COUNTY RETAINS THE RIGHT TO USE POSTED SURETY TO COMPLETE ANY RESTORATION WORK THAT HAS NOT BEEN COMPLETED IN THE 45 DAY PERIOD. ALTERNATIVE TEMPORARY TRENCH PROTECTION (STEEL PLATES OR OTHERS) MAY BE APPROVED BY THE CONSTRUCTION COORDINATION DIVISION.
- 11) FOR THE FINAL RESTORATION (INCLUDES THE PATCHED/SURFACE REPLACEMENT AREA OVER THE TRENCH), THE ROAD SHALL BE MILLED AND RESURFACED WITH 1-1/2" (ONE AND A HALF INCH) OF SP 12.5 STRUCTURAL COURSE (TRAFFIC LEVEL A) WITH TACK COAT AT 0.05 GAL/SY AND RC-70 PRIME COAT AT 0.10 GAL./SY. FOR A FULL LANE WIDTH ENCROACHED BY THE TRENCH INCLUDING A TRANSITION AREA OF 25 FT. EACH SIDE MEASURED FROM TOP OF TRENCH.
- 12) APPROVED MAGNETIC TAPE IS REQUIRED FOR ALL MAIN PRESSURE PIPES AND CONDUIT IN THE COUNTY'S RIGHT-OF-WAY. INSTALL TAPE 24" BELOW FINISHED GRADE.
- 13) CONTINUOUS 4" WIDE PAINT STRIPING IS REQUIRED FOR DIP/PCCP WATER MAINS (BLUE), DIP SANITARY FORCE MAINS (GREEN), DIP RECLAIMED WATER MAINS (PURPLE), GAS MAINS (YELLOW), OR AS REQUIRED BY THE APWA .

**WUD ONLY UTILITY NOTE:**

**THE CONTINUOUS PAINTED STRIPE REFERENCED IN NOTE #13 ABOVE SHALL BE EUCLID GREEN IN COLOR PER WUD STANDARDS.**

**PALM BEACH COUNTY CONSTRUCTION STANDARDS & DETAILS**

REVISION/ISSUE DATE

01/2023\*

**OPEN CUT PIPE INSTALLATION  
NON-THOROUGHFARE ROAD\***

PAGE NO.

6S\*



## CONSTRUCTION PROCEDURES

THE BACKFILL FOR THE FIRST AND SECOND STAGES SHALL BE PLACED IN 6" LAYERS (COMPACTED THICKNESS) AND SHALL BE COMPACTED TO 100% OF MAXIMUM DENSITY AS DETERMINED BY AASHTO T-99.

### STAGE 1:

THE CONTRACTOR SHALL PROVIDE ADEQUATE COMPACTED FILL BENEATH THE HAUNCHES OF THE PIPE, USING MECHANICAL TAMPS SUITABLE FOR THIS PURPOSE. THIS COMPACTION APPLIES TO THE MATERIAL PLACED BENEATH THE HAUNCHES OF THE PIPE AND ABOVE ANY BEDDING REQUIRED.

### STAGE 2:

THE CONTRACTOR SHALL OBTAIN A WELL-COMPACTED BED AND FILL ALONG THE SIDES OF THE PIPE AND TO A POINT INDICATING THE TOP OF SUB-GRADE MATERIAL.

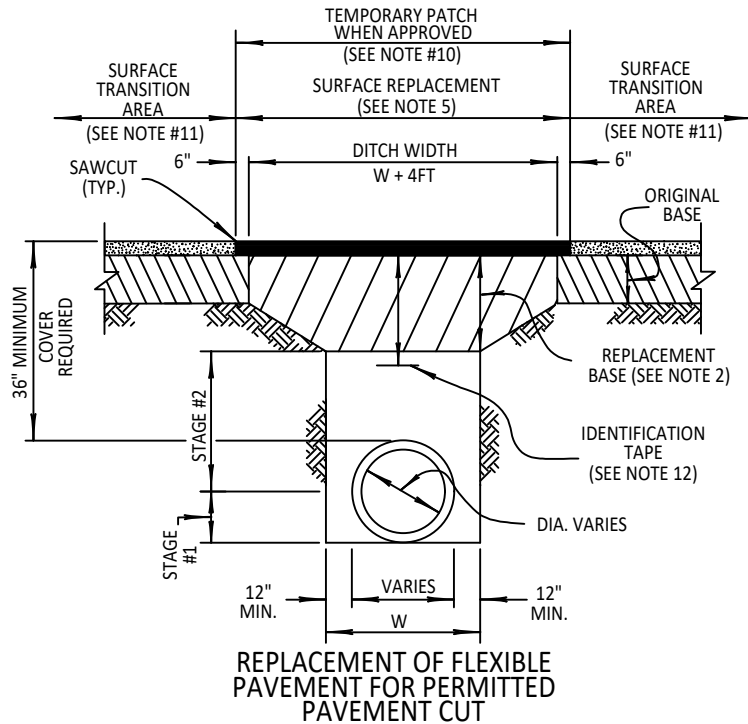

## NOTES

- 1) BEDDING SHALL CONSIST OF IN-SITU GRANULAR MATERIAL OR WASHED AND GRADED LIMEROCK 3/8" - 7/8" SIZING WITH EQUAL OR GREATER STRUCTURAL ADEQUACY AS EXISTING. UNSUITABLE IN-SITU MATERIALS SUCH AS MUCK, DEBRIS AND LARGER ROCKS SHALL BE REMOVED.
- 2) REPLACED BASE MATERIAL OVER DITCH SHALL BE 16" LIMEROCK (LBR100) MINIMUM FOR THOROUGHFARE PLAN ROADS. ANY ALTERNATE BASE MATERIAL REQUESTED BY THE ENGINEER OF RECORD REQUIRES APPROVAL BY THE ROADWAY PRODUCTION DIVISION.
- 3) ASPHALT CONCRETE PAVEMENT JOINTS SHALL BE MECHANICALLY SAWED AND BUTT-JOINTED.
- 4) BASE MATERIAL (PER ROADWAY PRODUCTION DESIGN STANDARDS) SHALL BE PLACED IN TWO OR THREE LAYERS (6" MAX. PER LAYER) AND EACH LAYER THOROUGHLY ROLLED OR TAMPED TO THE SPECIFIED DENSITY. (MINIMUM 98% AASHTO-T-180).
- 5) 1" FRICTION COURSE FC-9.5 OVER 1-1/2" TYPE SP STRUCTURAL COURSE (TRAFFIC LEVEL C) WITH TACK COAT AT 0.05 GAL/SY AND RC-70 PRIME COAT AT 0.10 GAL/SY FOR LIMEROCK BASE. FOLLOW THE LATEST FDOT SPECIFICATIONS FOR APPLICATION RATES OF PRIME AND TACK COATS. CONTRACTOR TO SUBMIT MATERIALS AND RATES TO ENGINEER FOR APPROVAL PRIOR TO BEGINNING WORK.
- 6) PIPE SHALL BE PLACED IN A DRY TRENCH.
- 7) ALL ROADWAY REPAIR WORK SHALL BE PERFORMED IN CONFORMANCE WITH APPLICABLE FDOT STANDARD SPECIFICATIONS FOR ROAD AND BRIDGE CONSTRUCTION AND COUNTY PPM# EL-0-3605.
- 8) DENSITY TESTS SHALL BE TAKEN IN 1 FT LIFTS ABOVE THE PIPE AT INTERVALS OF 400 FT MAXIMUM (1 SET MINIMUM) OR AS DIRECTED BY THE CONSTRUCTION COORDINATION DIVISION. RESULTS SHALL BE SUBMITTED TO CONSTRUCTION COORDINATION DIVISION AS PART OF THEIR FIELD REVIEW.
- 9) ENGINEER-OF-RECORD SHALL PROVIDE FULL-TIME INSPECTION DURING THE ENTIRETY OF THE OPEN-CUT OPERATION, BEGINNING WITH THE EXCAVATION AND CONTINUING THROUGH THE COMPLETION OF THE PAVING.
- 10) IF THE PAVEMENT IS NOT COMPLETELY RESTORED IMMEDIATELY FOLLOWING THE OPEN CUT, A SMOOTH TEMPORARY PATCH (MINIMUM 2.5" SP 12.5 STRUCTURAL COURSE ASPHALT) SHALL BE INSTALLED, PROPERLY MATCHING THE EXISTING GRADING OF THE ROADWAY. THE TEMPORARY PATCH SHALL BE ALLOWED TO REMAIN IN PLACE AND BE MAINTAINED FOR A PERIOD NO LONGER THAN 45 DAYS. THE COUNTY RETAINS THE RIGHT TO USE POSTED SURETY TO COMPLETE ANY RESTORATION WORK THAT HAS NOT BEEN COMPLETED IN THE 45 DAY PERIOD. ALTERNATIVE TEMPORARY TRENCH PROTECTION (STEEL PLATES OR OTHERS) MAY BE APPROVED BY THE CONSTRUCTION COORDINATION DIVISION.
- 11) FOR FINAL RESTORATION (INCLUDES THE PATCHED/SURFACE REPLACEMENT AREA OVER THE TRENCH). THE ROAD SHALL BE MILLED 1" MILLING DEPTH/ RESURFACED PER NOTE 5 ABOVE FOR A FULL LANE WIDTH OF THE TRAVEL LANES ENCROACHED BY THE TRENCH AREA, INCLUDING A TRANSITION AREA OF 50 FT. ON EACH SIDE MEASURED FROM TOP OF TRENCH.
- 12) APPROVED MAGNETIC TAPE IS REQUIRED FOR ALL MAIN PRESSURE PIPES AND CONDUIT IN THE COUNTY'S RIGHT-OF-WAY. INSTALL TAPE 24" BELOW FINISHED GRADE.
- 13) CONTINUOUS 4" WIDE PAINT STRIPING IS REQUIRED FOR DIP/PCCP WATER MAINS (BLUE), SANITARY MAINS (GREEN), DIP RECLAIMED WATER MAINS (PURPLE), GAS MAINS (YELLOW), OR AS REQUIRED BY THE APWA.

### WUD ONLY UTILITY NOTE:

**THE CONTINUOUS PAINTED STRIPE REFERENCED IN NOTE #13 ABOVE SHALL BE EUCLID GREEN IN COLOR PER WUD STANDARDS.**

## PALM BEACH COUNTY CONSTRUCTION STANDARDS & DETAILS

REVISION/ISSUE DATE

01/2023\*

OPEN CUT PIPE INSTALLATION  
THOROUGHFARE ROAD\*

PAGE NO.

7S\*

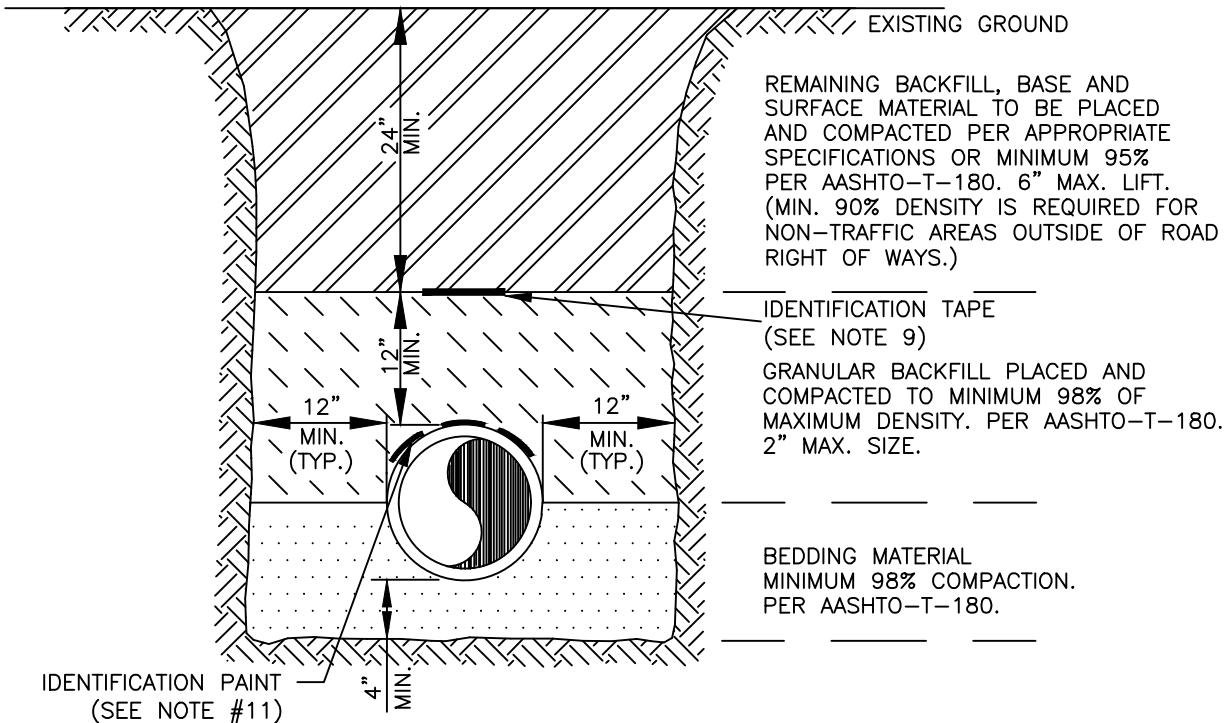

**NOTES:\***

1. BEDDING SHALL CONSIST OF IN-SITU GRANULAR MATERIAL OR WASHED AND GRADED LIMEROCK 3/8"- 7/8" SIZING. UNSUITABLE IN-SITU MATERIALS SUCH AS MUCK, DEBRIS AND LARGER ROCKS SHALL BE REMOVED.
2. THE PIPE SHALL BE FULLY SUPPORTED FOR ITS ENTIRE LENGTH WITH APPROPRIATE COMPACTION UNDER THE PIPE HAUNCHES.
3. THE PIPE SHALL BE PLACED IN A DRY TRENCH.
4. BACKFILL SHALL BE FREE OF UNSUITABLE MATERIAL SUCH AS LARGE ROCK, MUCK AND DEBRIS.
5. DENSITY TESTS ARE REQUIRED IN 1 FOOT ABOVE THE PIPE AT INTERVALS OF 400' MAXIMUM, MINIMUM 1 SET OF TESTS FOR EACH WASTEWATER GRAVITY MAIN RUN, OR AS DIRECTED BY THE INSPECTOR.
6. THE DEVELOPER/CONTRACTOR SHALL BE RESPONSIBLE TO COMPLY WITH ALL TRENCH SAFETY LAWS AND REGULATIONS.
7. SEE SEPARATE DETAILS FOR "PIPE INSTALLATION UNDER EXISTING PAVEMENT - OPEN CUT."
8. THE AFFECTED AREA SHALL BE RESTORED TO EQUAL OR BETTER CONDITION OR AS SPECIFIED IN PERMIT/CONTRACT DOCUMENTS.
9. APPROVED 6" WIDE MAGNETIC TAPE IS REQUIRED ON ALL FORCE MAINS.\*
10. CONTINUOUS FOUR (4) INCH WIDE GREEN PAINT STRIPPING IS REQUIRED FOR FORCE MAIN DUCTILE IRON PIPE (D.I.P.) INSTALLED BELOW GRADE ONLY.\*
11. A CONTINUOUS 4" WIDE PAINTED STRIP (GREEN) IS REQUIRED FOR ALL DIP SEWER (FORCE OR GRAVITY) MAINS.\*
12. WASTEWATER MAIN INSTALLATIONS WITHIN PUBLIC ROAD RIGHT-OF-WAYS SHALL BE BY THE SPECIFICATIONS OF THE JURISDICTION GRANTING THE RIGHT-OF-WAY UTILITY PERMIT.\*
13. FOR PIPE INSTALLATIONS IN ROAD RIGHTS-OF-WAY, ROAD OWNER'S PERMIT SPECIFICATIONS SHALL APPLY.

PALM BEACH COUNTY CONSTRUCTION STANDARDS & DETAILS

REVISION/ISSUE DATE

01/2023\*

WASTEWATER TRENCH DETAIL\*

PAGE NO.

8S

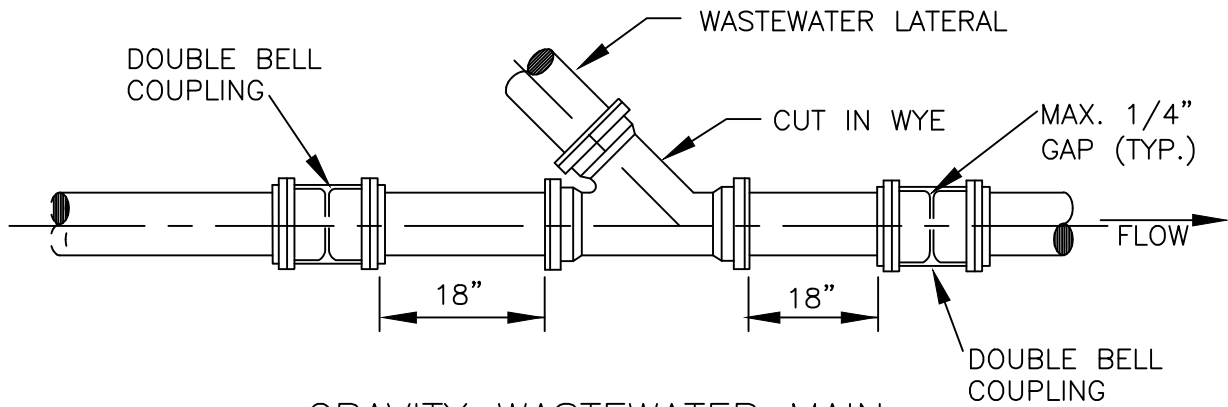

GRAVITY WASTEWATER MAIN

NOTE: DUCTILE IRON FITTINGS (WYE, TEE, SLEEVES) ARE REQUIRED FOR DUCTILE IRON AND/OR C-900 PVC MAIN.

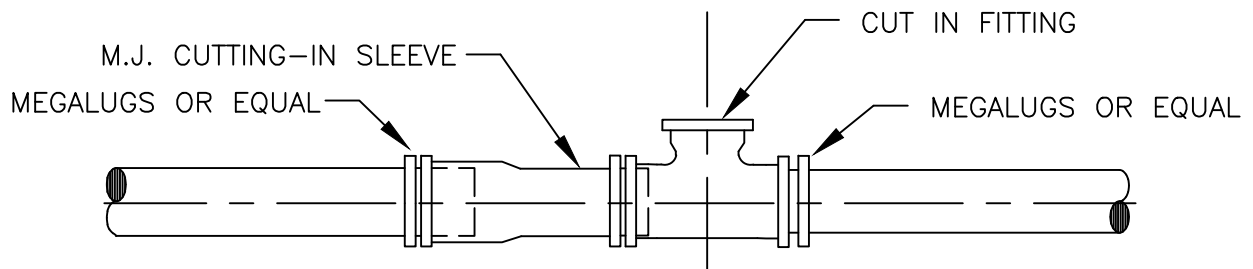

1. MEGALUGS OR EQUAL ARE REQUIRED THROUGHOUT ASSEMBLY.

DUCTILE IRON-MECHANICAL JOINT (FORCE MAIN)

# I. FORCE MAINS AND GRAVITY WASTEWATER MAINS WITHIN WELLFIELD PROTECTION ZONE.

- NOTES: 1. PRESSURE TEST PROCEDURE TO FOLLOW THE CURRENT AWWA C-600 STANDARD (150psi, (2) HOUR DURATION).
2. THERE SHALL BE NO PRESSURE DROP IN THE PIPE DURING THE TEST ("ZERO" FILL-UP TOLERANCE).

# II. FORCE MAINS OUTSIDE OF WELLFIELD PROTECTION ZONE

MAXIMUM QUANTITY OF WATER (GALLONS PER HOUR) THAT MAY BE SUPPLIED TO MAINTAIN PRESSURE WITHIN 5 P.S.I. OF THE SPECIFIED TEST PRESSURE,  
(MECHANICAL OR PUSH-ON JOINT, 18 FT. NOMINAL LENGTHS, PER 1000 FT. OF PIPE)

AVG. TEST PRESSURE PSI	PIPE DIAMETER (INCHES)															
	2	3	4	6	8	10	12	14	16	18	20	24	30	36	42	48
150	0.10	0.14	0.18	0.27	0.37	0.46	0.55	0.64	0.73	0.83	0.92	1.10	1.38	1.65	1.93	2.20

$$\text{FORMULA BASIS: } L = \frac{(S) \times (D) \times (P)^{1/2}}{148,000} \times 1/2$$

- L = MAXIMUM QUANTITY OF WATER TO BE ADDED (GALLONS PER HOUR)
- S = LENGTH OF PIPE TESTED (FEET)
- D = DIAMETER OF PIPE (INCHES)
- P = TEST PRESSURE (P.S.I.)

NOTES:

1. TO OBTAIN THE MAXIMUM QUANTITY OF WATER FOR PIPE WITH 20 FT. NOMINAL LENGTHS, MULTIPLY THE QUANTITY CALCULATED FROM THE TABLE BY 0.9
2. THE MAXIMUM QUANTITY OF ADDED WATER FOR A PIPELINE IS CALCULATED BY MULTIPLYING THE QUANTITY PER HOUR AS OBTAINED FROM THE ABOVE TABLE, BY THE DURATION OF THE TEST IN HOURS, AND BY THE TOTAL LENGTH OF THE LINE BEING TESTED DIVIDED BY 1,000. IF THE LINE UNDER TEST CONTAINS SECTIONS OF VARIOUS DIAMETERS, THE MAXIMUM QUANTITY ADDED WILL BE THE SUM OF THE COMPUTED QUANTITIES FOR EACH SIZE.
3. MAXIMUM TEST LENGTH = 2,500 FEET PER SECTION.
4. THIS STANDARD SHALL REFLECT ANY REVISION OF A.W.W.A. C-600. HOWEVER, THE MAXIMUM QUANTITY OF WATER ADDED SHALL NOT EXCEED 50% OF THE RECOMMENDED LIMIT PER APPLICABLE AWWA C-600 STANDARD.
5. STANDARD TEST PRESSURE = 150 P.S.I.
6. PRESSURE TEST DURATION TO BE MIN. 2 HOURS.

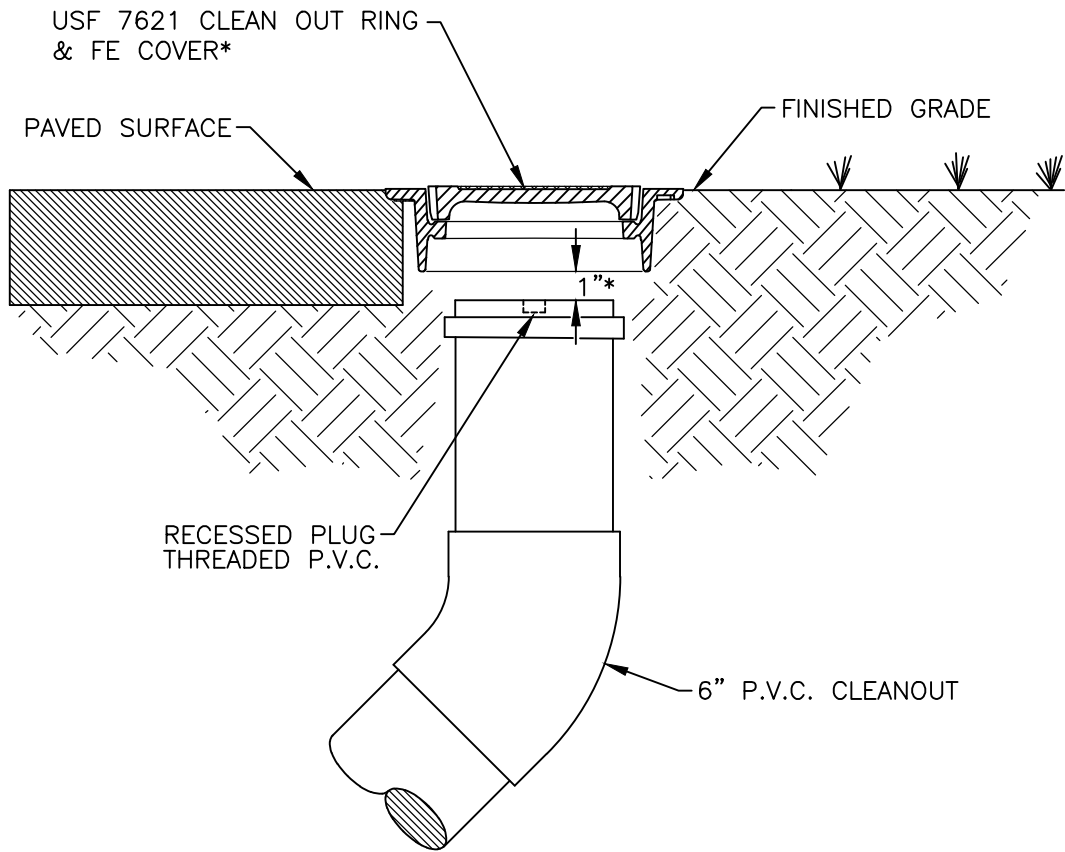

1. CLEANOUTS TO BE LOCATED IN GRASS AREA WHENEVER POSSIBLE WITH A MINIMUM OF THREE (3) FEET FROM EDGE OF PAVEMENT, BACK OF CURB, EDGE OF DRIVEWAY, AND TRANSFORMERS ON RESIDENTIAL AND NON-RESIDENTIAL LOTS UNLESS LOTS ARE ASSOCIATED WITH TOWNHOME OR ZERO LOT LINE LOTS. ON ZERO LOT LINE LOTS THE MINIMUM DIMENSION SHALL BE ONE (1) FOOT INSTEAD OF THREE (3) FOOT MINIMUM UNLESS OTHERWISE APPROVED BY THE DEPARTMENT.\*
2. CLEANOUTS SHALL NOT BE INSTALLED IN TRAFFIC LANES OR AREAS UNDER HEAVY TRAFFIC LOADS.
3. THE COVER TO BE MARKED "S".
4. CLEANOUTS TO BE INSTALLED PRIOR TO WATER METER RELEASE.
5. THE DEVELOPER/PROPERTY OWNER OR ASSIGNEE SHALL BE RESPONSIBLE FOR CLEANOUT INSTALLATION PRIOR TO WATER METER INSTALLATION AS SPECIFIED BY THE DEPARTMENT.
6. A CONCRETE COLLAR MAY BE REQUIRED IF CLEANOUT IS LOCATED BETWEEN DRIVEWAYS. SPECIAL CONSTRUCTION DETAIL WILL BE REQUIRED.
7. ALONG STREETS WITH ADJACENT NON-EXCLUSIVE UTILITY EASEMENT, THE CLEANOUTS ENDING PBCWUD MAINTENANCE RESPONSIBILITY SHALL BE INSTALLED MIN. 12", MAX. 18" INTO THE EASEMENT.

PALM BEACH COUNTY CONSTRUCTION STANDARDS & DETAILS

REVISION/ISSUE DATE

01/2023\*

TYPICAL  
CLEANOUT INSTALLATION

PAGE NO.

11SA\*

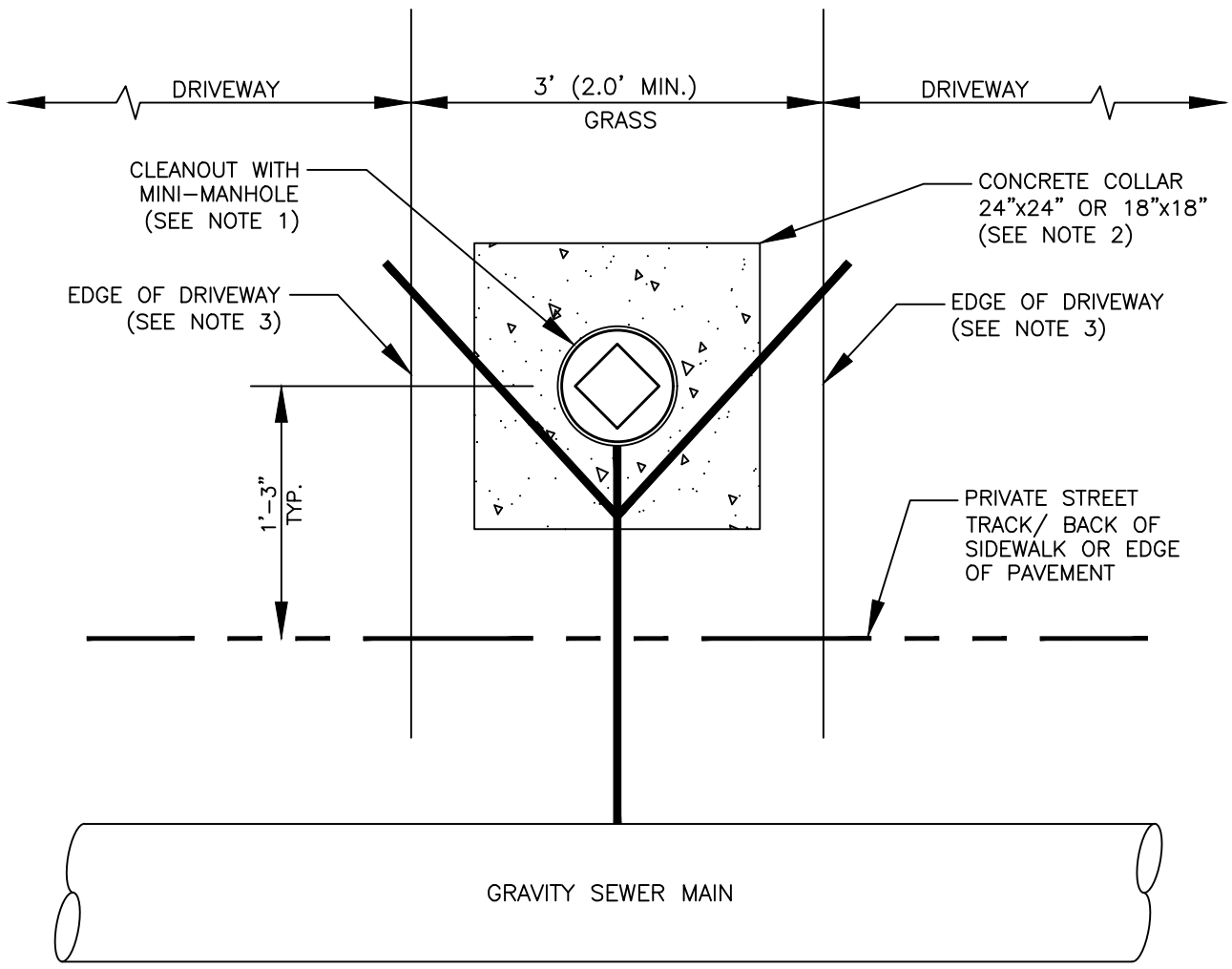

NOTES:

1. CLEANOUT WITH MINI-MANHOLE MUST BE CENTERED BETWEEN DRIVEWAYS IN GRASS AREA.
2. DRIVEWAYS THAT ARE SEPARATED BY (3)THREE FEET INSTALL A 24"x24" CONCRETE COLLAR. WHEN THERE IS LESS THAN (3)THREE FEET SEPARATION BETWEEN DRIVEWAYS INSTALL A 18"x18" CONCRETE COLLAR.
3. THE EDGE OF THE DRIVEWAY IS EITHER THE ASPHALT/CONCRETE PAVEMENT AREA AND/OR PAVER BRICK AREA WHICH MAY INCLUDE ANY CONCRETE EDGING.



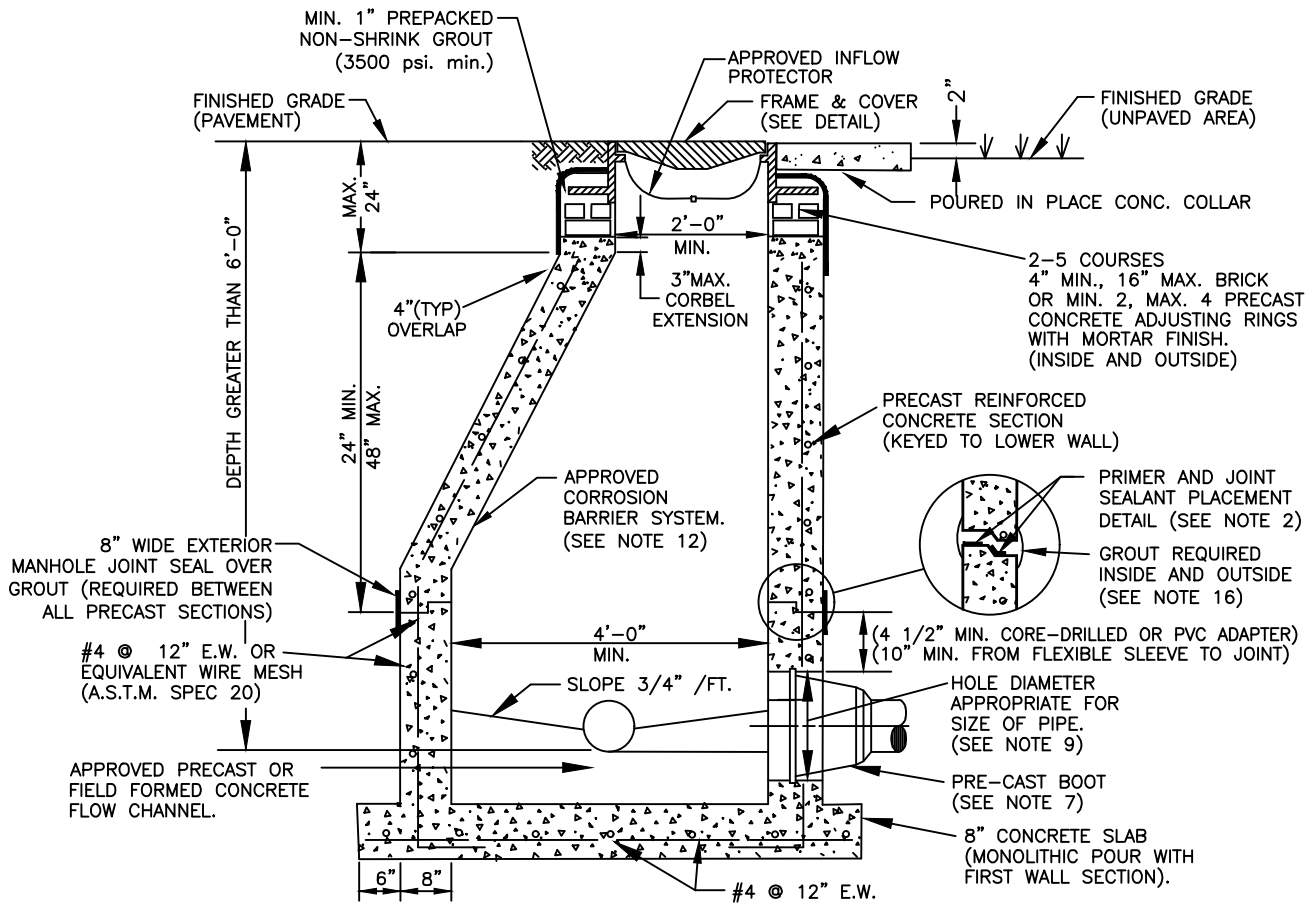

**NOTES:**

1. PRECAST CONCRETE TYPE II 4000 P.S.I. CALCAREOUS AGGREGATE REQUIRED (MIN. CaCO<sub>3</sub> CONTENT: 65% IN LARGE AGGREGATE, 50% IN CONCRETE SCREENING).
2. INSTALL APPROVED JOINT SEALANT AT ALL RISER JOINTS WITH GROUT ON INSIDE AND OUTSIDE. MANHOLE SHOP DRAWINGS SHALL INCLUDE THE SIZE AND PLACEMENT OF JOINT SEALANT. AN APPROVED JOINT PRIMER SHALL BE APPLIED BY THE PRECASTER (TONGUE SECTION ONLY).
3. ALL OPENINGS SHALL BE SEALED WITH A WATERPROOF NON-SHRINKING GROUT.
4. FLOW CHANNELS SHALL BE PRECAST OR FIELD CONSTRUCTED TO DIRECT INFLUENT INTO FLOW STREAM. (SEE DETAIL)
5. LIFT HOLES ARE PERMITTED.
6. ALL PIPE HOLES SHALL BE PRECAST OR CORE - DRILLED.
7. A. FOR PVC PIPE ENTERING MANHOLE WITH PRECAST HOLES USE THE APPROVED. PRECASTED FLEXIBLE MANHOLE SLEEVE FOR THE APPROPRIATE PIPE DIAMETER AND DIMENSION RATIO. DOUBLE BANDING IS REQUIRED FOR FLEXIBLE MANHOLE SLEEVE.  
 B. CONNECTION TO A MANHOLE WITH A CORE DRILLED HOLE SHALL BE MADE USING A 5' MIN. PVC C900 DR 18 AND THE APPROVED PVC-MANHOLE ADAPTER. THE ADAPTER SHALL NOT EXTEND MORE THAN 1" INTO THE MANHOLE.  
 C. THE INSIDE AND OUTSIDE SPACE BETWEEN PIPE AND MANHOLE WALL SHALL BE FILLED WITH GROUT
8. INSIDE DROPS SHALL NOT BE DESIGNED TO EXCEED 1.80 FEET AND NOT CONSTRUCTED TO EXCEED 2.0 FEET. MAX. 6" INSIDE DROP IS PERMITTED FOR MANHOLES WITH 3 OR MORE INVERTS AND MANHOLES WITH A CHANGE IN FLOW DIRECTION OF MORE THAN 45 DEGREES.
9. 8" DIAMETER PIPE: 15" HOLE FOR PVC - 10" DIAMETER PIPE: 17" HOLE FOR PVC.
10. MANHOLE FABRICATION SHALL BE IN ACCORDANCE WITH ASTM C-478, LATEST STANDARD.
11. MINIMUM 5 FEET IS REQUIRED BETWEEN OUTSIDE OF MANHOLE AND A SERVICE WYE.
12. MANHOLES TO BE COATED INSIDE WITH AN APPROVED CORROSION BARRIER SYSTEM. SOLID THERMOPLASTIC CAST-IN LINER IS REQUIRED FOR LAST MANHOLE PRIOR TO LIFT STATION, MANHOLES DEEPER THAN 14 FT., MANHOLES WITH OUTSIDE DROP, AND MANHOLES WITH A FORCE MAIN CONNECTION. (SEE APPROPRIATE DETAILS)
13. APPROVED INFLOW PROTECTORS ARE REQUIRED.
14. MANHOLES IN ROADWAYS SHALL BE LOCATED OUTSIDE OF WHEEL PATHS.
15. SPECIAL PRE-APPROVED GROUT IS REQUIRED FOR PRECAST STRUCTURES WITH ANTIMICROBIAL ADMIXTURE.

PALM BEACH COUNTY CONSTRUCTION STANDARDS & DETAILS

REVISION/ISSUE DATE

6/2019

STANDARD MANHOLE

PAGE NO.

13S



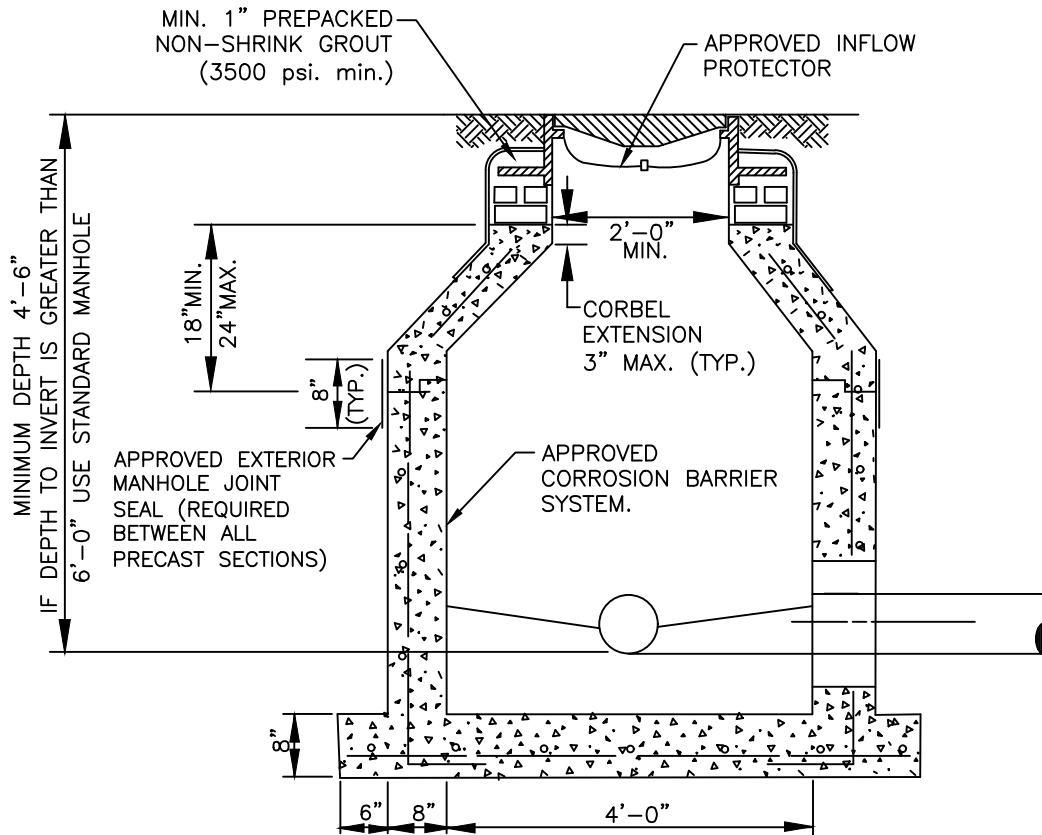

NOTE:

ALL STANDARD MANHOLE NOTES AND DETAILS ARE APPLICABLE

PALM BEACH COUNTY CONSTRUCTION STANDARDS & DETAILS

REVISION/ISSUE DATE

6/2019

SHALLOW MANHOLE

PAGE NO.

14S

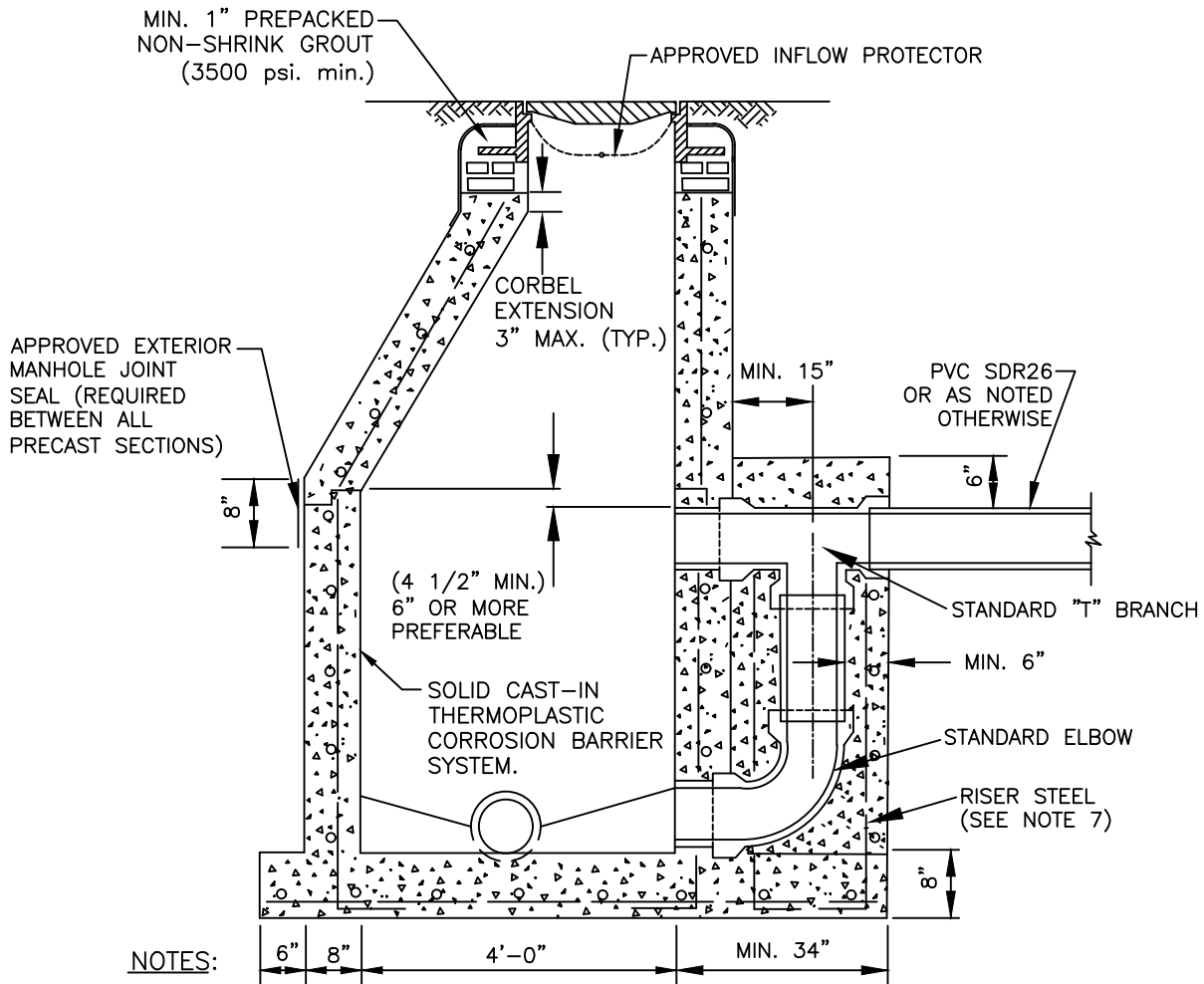

1. ALL DETAILS AND SPECIFICATIONS FOR STANDARD MANHOLES ARE APPLICABLE EXCEPT FOR REFERENCES TO DROP ASSEMBLY AND CAST IN LINERS.
2. THE PRECAST BASE SHALL EXTEND FULLY UNDER THE DROP ASSEMBLY.
3. MASONRY CONSTRUCTION ABOVE THE EXTENDED PRECAST BASE, IF FILLED WITH CONCRETE, IS PERMISSIBLE.
4. BRICK AND CONCRETE RUBBLE ARE PERMITTED AS FILLER IN DROP ENCASEMENT.
5. DROP CONNECTIONS SHALL BE REQUIRED WHENEVER AN INFLUENT INVERT IS LOCATED 2.0 FEET OR MORE ABOVE THE MAIN INVERT CHANNEL. DROP CONNECTIONS SHOULD NOT BE DESIGNED FOR LESS THAN A 2.4 FOOT DROP.
6. PVC SDR 26 PIPE WITH PVC SDR 35 FITTINGS SHALL BE UTILIZED IN THE DROP ASSEMBLY.
7. RISER STEEL TO BE CAST IN PLACE WITH BASE (4 RODS) OR USE 4 - 1/2" DIA. COIL LOOP INSERTS CAST IN PLACE WITH BASE (TO BE USED WITH 1/2" COIL RODS). COIL LOOP INSERTS TO BE "DAYTON SUPERIOR" B16, 1/2"x 4" OR APPROVED EQUAL.

PALM BEACH COUNTY CONSTRUCTION STANDARDS & DETAILS

REVISION/ISSUE DATE

6/2019

DROP CONNECTION PRECAST MANHOLE

PAGE NO.

155

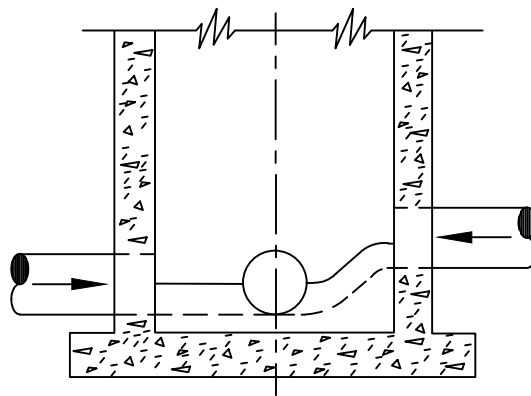
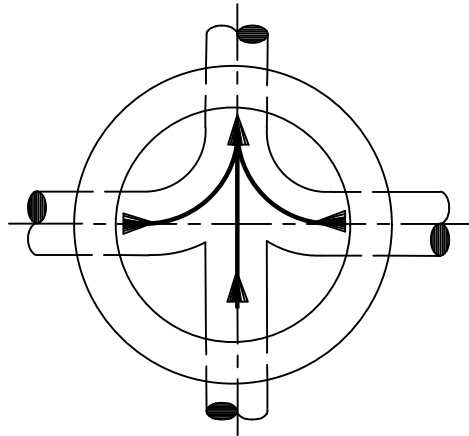

NOTES:

1. PROPERLY SHAPED INVERT CHANNELS AND SPILLWAYS SHALL BE CONSTRUCTED BETWEEN PIPES WITH DIFFERENT INVERT ELEVATIONS TO PROVIDE FOR SMOOTH FLOWS.
2. SERVICE LATERALS SHALL NOT ENTER MANHOLES UNLESS SPECIFIED ON PLANS AND THEN MUST BE TREATED AS MAINS (ELEVATIONS SHOWN, PRECAST HOLE, FLOW CHANNEL)
3. APPROVED PRECAST POLYPROPYLENE OR FIBER REINFORCED POLYMER (FRP) FLOW CHANNELS WITH INTEGRATED PIPE INVERTS (SEE SEPARATE DETAILS), PRECAST CONCRETE FLOW CHANNELS, OR FIELD INSTALLED CONCRETE FLOW CHANNELS ARE REQUIRED.
4. SIDEWALLS OF FLOW CHANNELS SHALL BE AT LEAST HALF OF PIPE HEIGHT AT ALL POINTS.
5. NO INSIDE DROP LARGER THAN 6" SHALL BE ALLOWED WITH 3 OR 4 INVERTS AND MANHOLES WITH A CHANGE OF DIRECTION OF FLOW OF MORE THAN 45 DEGREES.
6. THE FIELD APPLIED CORROSION BARRIER SYSTEM SHALL BE INSTALLED AFTER INVERT CHANNEL CONSTRUCTION UNLESS PRECAST THERMOPLASTIC BASELINER IS USED. THE FIELD APPLIED CORROSION BARRIER MAY NOT BE APPLIED TO THE FLOW CHANNEL.

PALM BEACH COUNTY CONSTRUCTION STANDARDS & DETAILS

REVISION/ISSUE DATE

6/2019

INVERT FLOW CHANNELS

PAGE NO.

16S

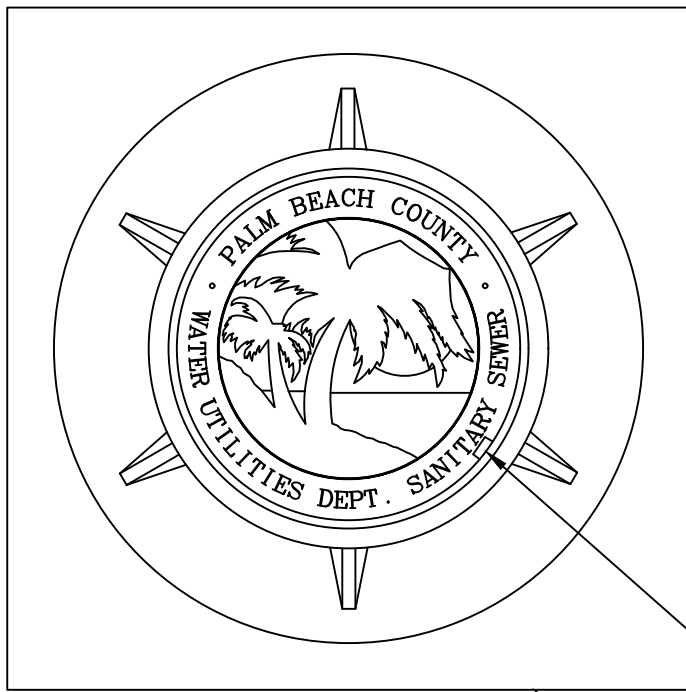

PICK HOLE

5'x 5'x 5" POURED IN PLACE CONCRETE COLLAR WITH WIRE MESH REINFORCING

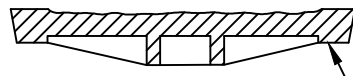

COVER

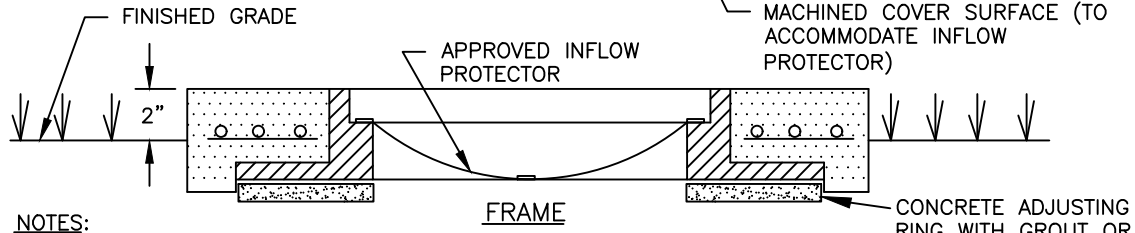

**NOTES:**

1. COLLAR IS REQUIRED ONLY WHEN MANHOLE IS OUT OF PAVEMENT.
2. STANDARD FRAME AND COVER SIZE SHALL BE SEVEN INCHES (7"). A 4" FRAME MAY ONLY BE USED WITH PRIOR APPROVAL.
3. A STEEL MANHOLE RISER, APPROVED PRECAST CONCRETE ADJUSTING RINGS OR ADDITIONAL BRICKS MAY BE USED TO ELEVATE EXISTING MANHOLE COVERS TO RESURFACED GRADE (MAX. 4" HEIGHT).
4. COVER SHALL FIT FLUSH WITH THE FRAME WITH THE INFLOW PROTECTOR INSTALLED.

PALM BEACH COUNTY CONSTRUCTION STANDARDS & DETAILS

REVISION/ISSUE DATE  
6/2019

GRAVITY SEWER MANHOLE FRAME & COVER

PAGE NO.  
17S

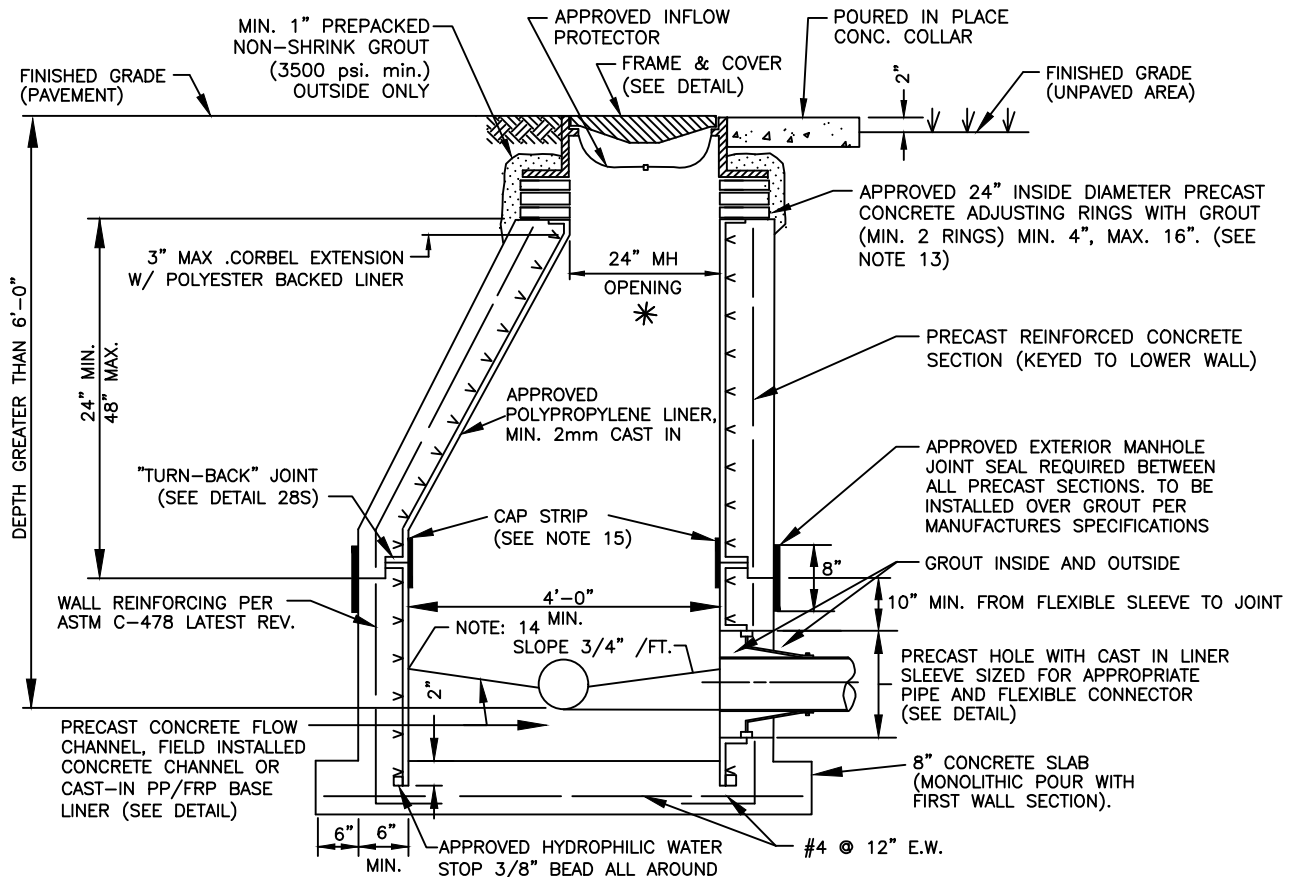

**NOTES:**

1. PRECAST CONCRETE TYPE II 4000 P.S.I. CALCAREOUS AGGREGATE REQUIRED (MIN. CaCO3 CONTENT: 65% IN LARGE AGGREGATE, 50% IN CONCRETE SCREENING).
2. APPROVED PRIMER AND SEALANT GASKET AT ALL RISER JOINTS. SEALANT GASKET SIZE AND PLACEMENT SHALL BE CALLED OUT ON SHOP DRAWINGS. PRIMER TO BE APPLIED BY THE PRECASTER (TONGUE SECTION ONLY).
3. ALL PIPE OPENINGS SHALL BE GAS TIGHT AND WATER TIGHT WITH NO EXPOSED CONCRETE SURFACES.
4. CAST OPENINGS SHALL BE MANUFACTURED WITH A POLYPROPYLENE SLEEVE CAST IN. APPROVED FLEXIBLE MANHOLE CONNECTORS SHALL BE USED AT PIPE CONNECTIONS. HOLE SIZE PER BOOT MANUFACTURER'S SPECIFICATIONS. DOUBLE PIPE CLAMPS MUST BE INSTALLED ON FLEXIBLE SLEEVES WHERE REQUIRED BY BOOT MANUFACTURERS INSTALLATION INSTRUCTIONS.
5. CORED PIPE OPENINGS SHALL BE INSTALLED PER DETAIL. APPROVED FLEXIBLE CONNECTOR WILL BE INSTALLED ONTO POLY-PROPYLENE WALL SLEEVE. WALL SLEEVE SHALL BE EPOXIED INTO CORED OPENING AND THERMAL WELDED TO WALL LINER.
6. FLOW CHANNELS SHALL BE CONSTRUCTED TO DIRECT INFLUENT INTO FLOW STREAM. APPROVED CAST-IN PP/FRP BASE LINER IS ACCEPTABLE (SEE DETAIL).
7. LIFT HOLES ARE PERMITTED.
8. INSIDE DROPS SHALL NOT BE DESIGNED TO EXCEED 1.80 FEET AND NOT CONSTRUCTED TO EXCEED 2.0 FEET. MAX. 6" INSIDE DROP IS PERMITTED FOR MANHOLES WITH 3 OR MORE INVERTS AND MANHOLES WITH A CHANGE IN FLOW DIRECTION OF MORE THAN 45 DEGREES.
9. MANHOLE FABRICATION SHALL BE IN ACCORDANCE WITH ASTM C-478, LATEST STANDARD.
10. MINIMUM 5 FEET IS REQUIRED BETWEEN OUTSIDE OF MANHOLE AND SERVICE WYE OR ANY PIPE JOINT.
11. ONLY APPROVED THERMOPLASTIC LINER SYSTEM SHALL BE USED. LINERS MUST BE WELDED BY LINER MFG CERTIFIED WELDERS AND BE CAST INTO THE MANHOLE BY A LINER MANUFACTURER CERTIFIED PRECASTER.
12. APPROVED INFLOW PROTECTORS ARE REQUIRED.
13. MAXIMUM HEIGHT OF CHIMNEY SHALL NOT EXCEED 24" (INCLUDING FRAME CASTING).
14. SEAL INVERT BENCH AND CHANNEL TO WALL LINER WITH 3M WEATHERBAN 5354 SEALANT TAPE OR APPROVED EQUAL.
15. MIN. 4" WIDE FIELD WELDED CAP STRIP IS REQUIRED FOR ALL JOINTS.
16. SOLID THERMOPLASTIC CAST-IN LINER IS REQUIRED FOR LAST MANHOLE PRIOR TO LIFT STATION. MANHOLES DEEPER THAN 14 FT., MANHOLES WITH OUTSIDE DROP, AND MANHOLES WITH A FORCE MAIN CONNECTION. (SEE APPROPRIATE DETAILS)
17. MANHOLES IN ROADWAYS SHALL BE LOCATED OUTSIDE OF WHEEL PATHS.

PALM BEACH COUNTY CONSTRUCTION STANDARDS & DETAILS

REVISION/ISSUE DATE

01/2023\*

STANDARD MANHOLE  
WITH CAST-IN LINER

PAGE NO.

18SA\*

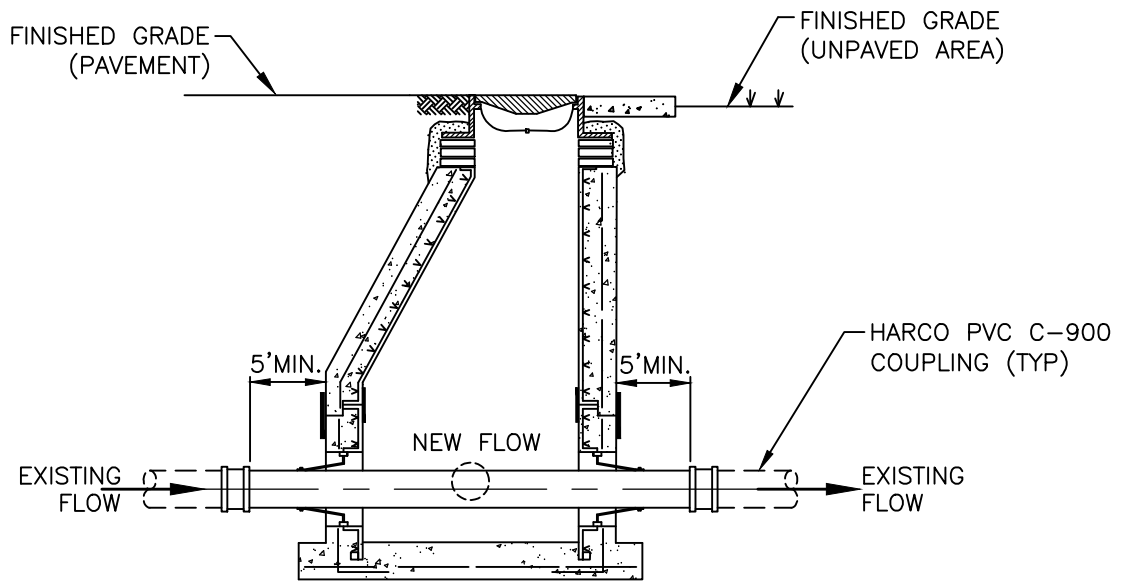

PROFILE

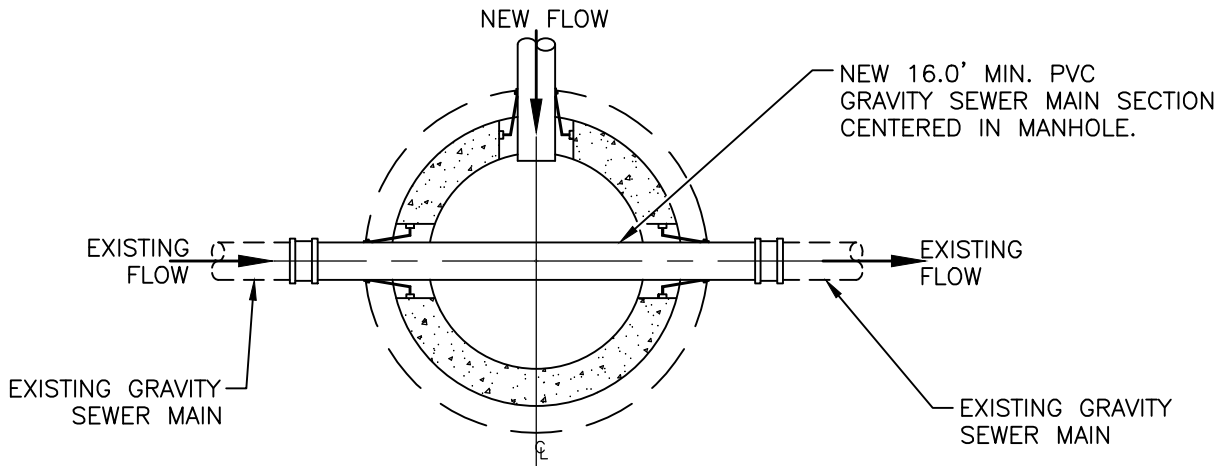

PLAN

NOTES:

1. MANHOLE TO BE CONSTRUCTED AND INSTALLED PER WUD STANDARD DETAIL 18SA.
2. A TEMPORARY GRAVITY SEWER MAIN BYPASS SIXTEEN(16) FOOT MINIMUM TO BE INSTALLED THROUGH NEW MANHOLE TO MAINTAIN EXISTING WASTEWATER FLOW DURING CONSTRUCTION OF NEW GRAVITY SEWER SYSTEM.
3. ONCE THE NEW GRAVITY SEWER SYSTEM INSTALLATION IS COMPLETED AND HAS RECEIVED FINAL DEP WASTEWATER CERTIFICATION THE TEMPORARY BYPASS PIPE SHALL BE CUT AND REMOVED FROM WITHIN THE MANHOLE WITH A NEW FLOW CHANNEL CONSTRUCTED PER WUD MINIMUM DESIGN STANDARDS.
4. AFTER ALL CONSTRUCTION HAS BEEN COMPLETED, INCLUDING THE REMOVAL OF THE BYPASS PIPE AND CONSTRUCTION OF THE NEW FLOW CHANNEL, THE EXISTING UPSTREAM AND DOWNSTREAM GRAVITY SEWER MAIN SHALL BE LAMPED TO VERIFY NO ADVERSE DAMAGE OCCURED DURING CONSTRUCTION TO THE EXISTING GRAVITY SEWER MAIN.

PALM BEACH COUNTY CONSTRUCTION STANDARDS & DETAILS

REVISION/ISSUE DATE

1/2023 \*

NEW MANHOLE CUT INTO EXISTING  
GRAVITY SEWER MAIN\*

PAGE NO.

18SB\*

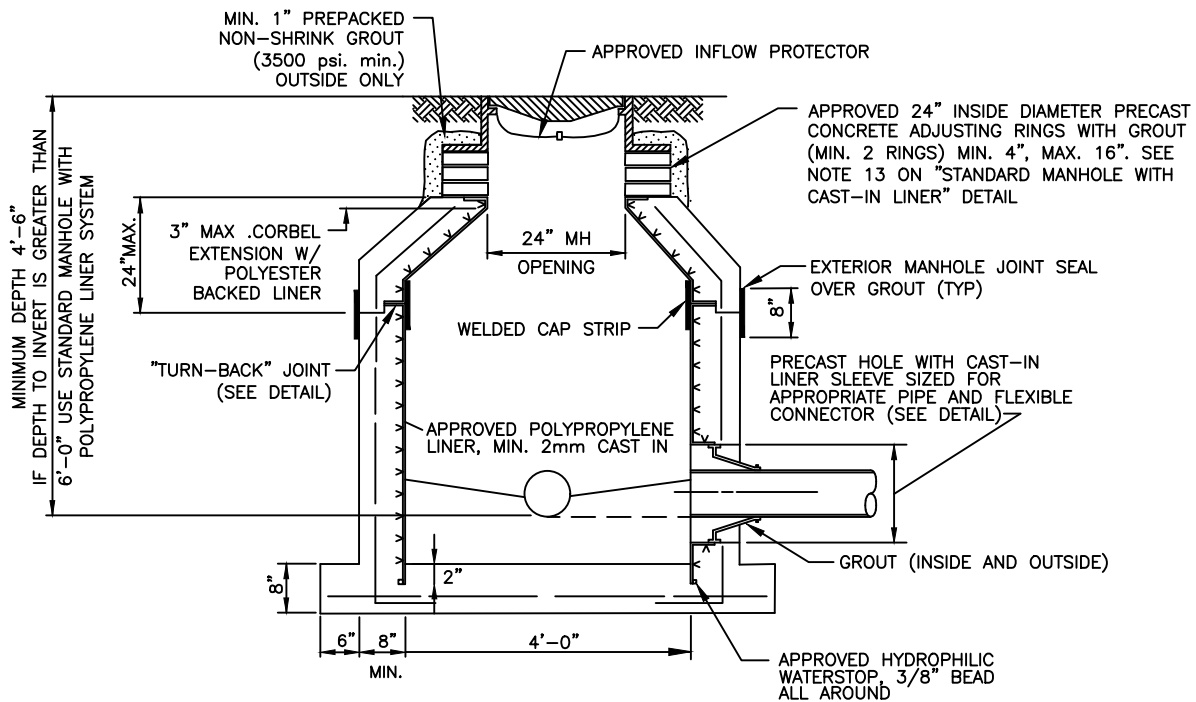

**NOTES:**

1. ALL "STANDARD MANHOLE WITH POLYPROPYLENE LINER SYSTEM" NOTES AND DETAILS ARE APPLICABLE.
2. SEAL INVERT BENCH AND CHANNEL TO WALL LINER WITH 3M WEATHERBAN 5354 SEALANT TAPE (OR APPROVED EQUAL).
3. SEE SEPARATE DETAIL FOR OPTIONAL CAST-IN POLYPROPYLENE OR FIBER REINFORCED POLYMER BASE LINER.

PALM BEACH COUNTY CONSTRUCTION STANDARDS & DETAILS

REVISION/ISSUE DATE

6/2019

SHALLOW MANHOLE  
WITH CAST-IN LINER

PAGE NO.

19S

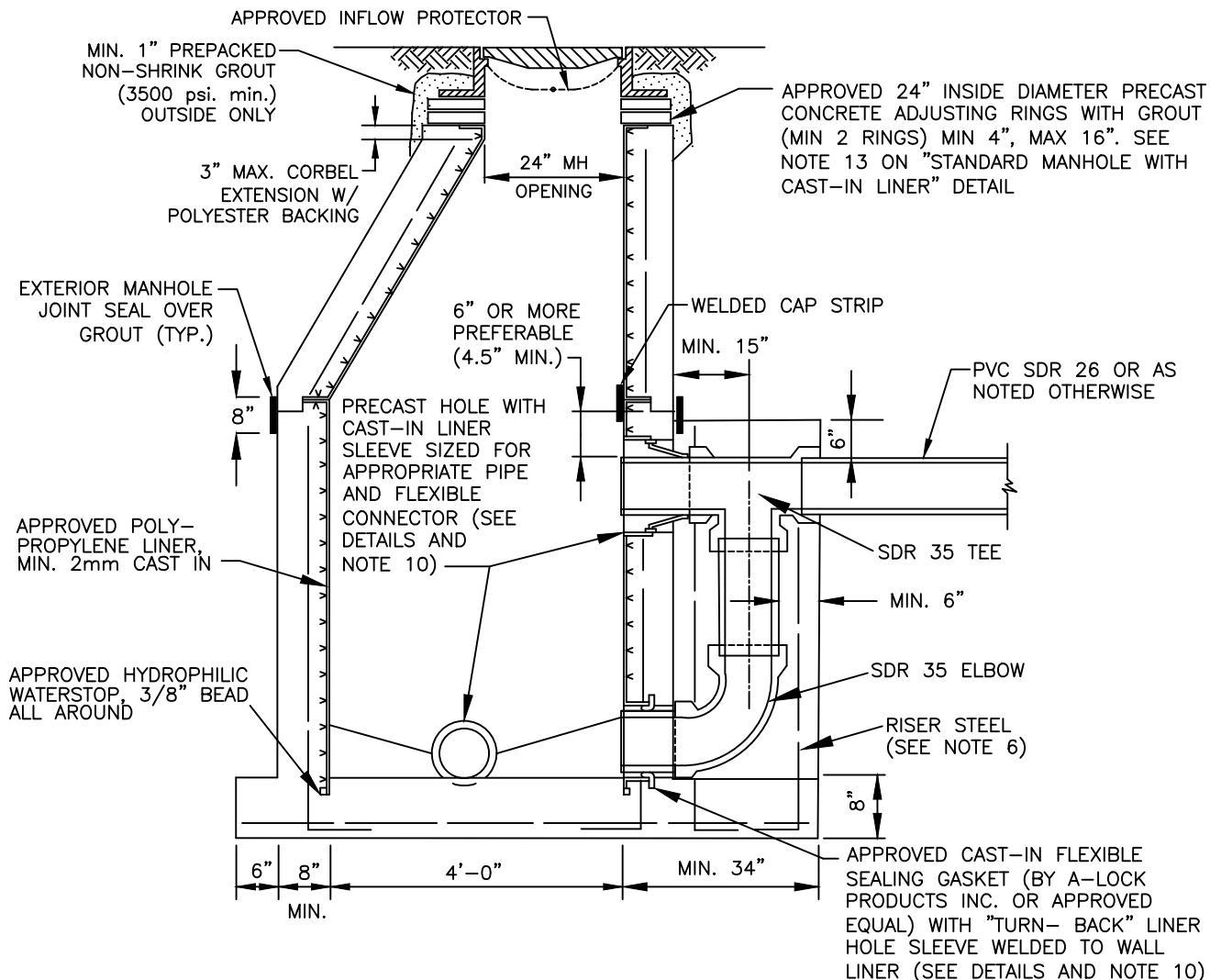

**NOTES:**

1. ALL DETAILS AND SPECIFICATIONS FOR "STANDARD MANHOLE WITH SOLID POLYPROPYLENE LINER SYSTEM" ARE APPLICABLE EXCEPT FOR REFERENCES TO DROP ASSEMBLY.
2. THE PRECAST BASE SHALL EXTEND FULLY UNDER THE DROP ASSEMBLY.
3. PRECAST DROP ENCASUREMENT REQUIRED UP TO TOP EDGE OF 90 DEGREE ELBOW, BRICK AND CONCRETE RUBBLE ARE PERMITTED AS FILLER IN REMAINDER OF DROP ENCASUREMENT.
4. DROP CONNECTIONS SHALL BE REQUIRED WHENEVER AN INFLUENT INVERT IS LOCATED 2.0 FEET OR MORE ABOVE THE MAIN INVERT CHANNEL. DROP CONNECTIONS SHOULD NOT BE DESIGNED FOR LESS THAN A 2.4 FOOT DROP.
5. PVC SDR 26 PIPE WITH PVC SDR 35 FITTINGS SHALL BE UTILIZED IN THE DROP ASSEMBLY.
6. DROP ENCASUREMENT REINFORCING STEEL TO BE CAST IN PLACE WITH BASE (4 RODS) OR USE 4-1/2" DIA. COIL LOOP INSERTS CAST IN PLACE WITH BASE (TO BE USED WITH 1/2" COIL RODS). COIL LOOP INSERTS TO BE "DAYTON SUPERIOR" B16, 1/2"X 4" OR APPROVED EQUAL.
7. MIN. 4" WIDE FIELD WELDED CAP STRIP IS REQUIRED OVER ALL JOINTS.
8. SEAL INVERT BENCH AND CHANNEL TO WALL LINER WITH 3M WEATHERBAN 5354 SEALANT TAPE (OR APPROVED EQUAL).
9. SEE SEPARATE DETAIL FOR OPTIONAL CAST-IN POLYPROPYLENE OR FIBER REINFORCED POLYMER BASE LINER.

PALM BEACH COUNTY CONSTRUCTION STANDARDS & DETAILS

REVISION/ISSUE DATE

6/2019

OUTSIDE DROP MANHOLE  
WITH CAST-IN LINER

PAGE NO.

20S



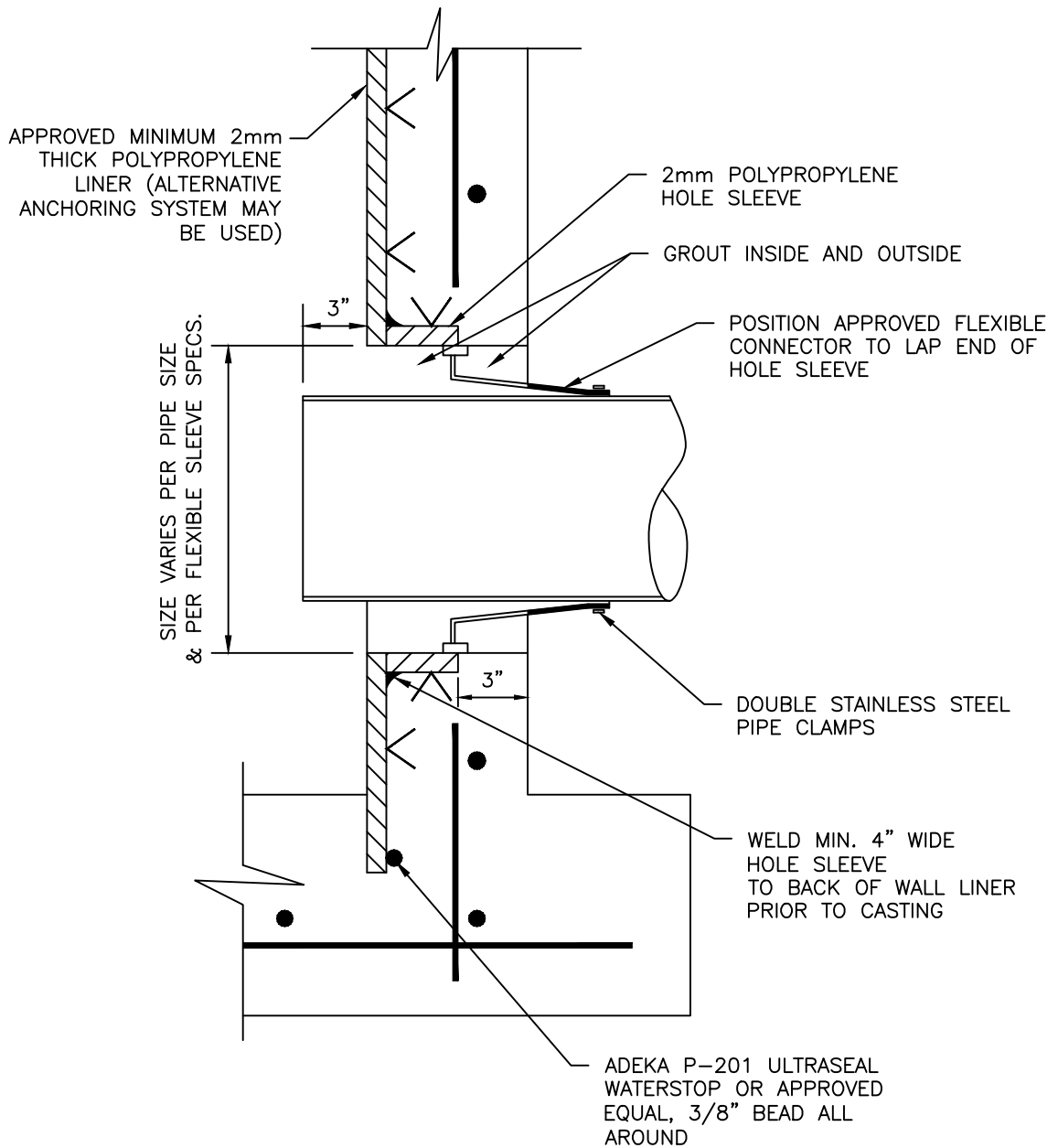

PALM BEACH COUNTY CONSTRUCTION STANDARDS & DETAILS

REVISION/ISSUE DATE

6/2019

PIPE TO MANHOLE CONNECTION – TYPE "A"

PAGE NO.

21S

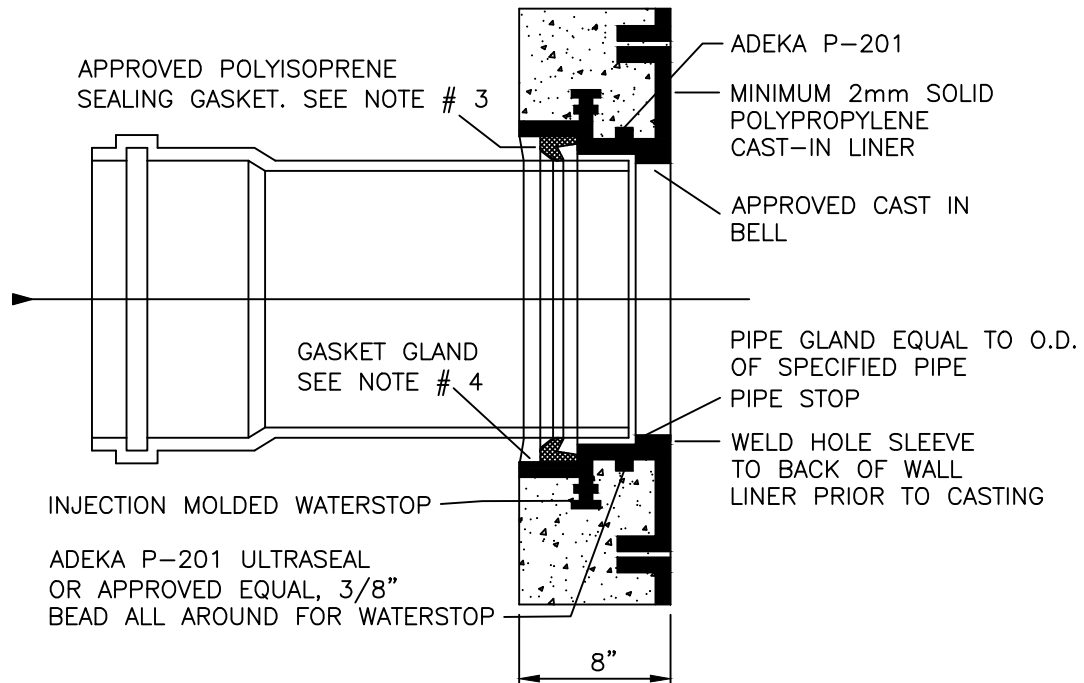

INSTALLATION:

- 1) CLEAN BELL
- 2) INSTALL GASKET AS SHOWN
- 3) LUBRICATE PIPE SPIGOT AND SLIDE INTO BELL AND GASKET UNTIL REACHING PIPESTOP
- 4) CHECK FOR WATERTIGHT CONNECTION

DO NOT LUBRICATE THE GASKET  
OR THE BELL

NOTES:

- 1) MANHOLE SHOP DRAWINGS SHALL IDENTIFY THE TYPE OF MANHOLE/PIPE CONNECTION.
- 2) MANHOLE SHOP DRAWINGS SHALL IDENTIFY THE PIPE SIZE, TYPE, GASKET TYPE, AND HOLE SIZE.
- 3) ONLY THE POLYISOPRENE GASKET SUPPLIED BY THE BELL MANUFACTURER SHALL BE USED IN COMPRESSION TYPE BELLS.
- 4) GASKET GLAND VARIES ACCORDING TO PIPE SIZE AND TYPE.
- 5) HOLE SLEEVES AND BELL CONNECTORS SHALL EXTEND TO THE OUTER PROFILE OF THE CONCRETE STRUCTURE AT MINIMUM PROVIDING A COMPLETELY LINED SURFACE WHERE THE GASKET AND HOLE LINER MATE TOGETHER.

CAST-IN BELL WITH COMPRESSION SEAL GASKET

PALM BEACH COUNTY CONSTRUCTION STANDARDS & DETAILS

REVISION/ISSUE DATE

6/2019

PIPE TO MANHOLE CONNECTION – TYPE "B"

PAGE NO.

22S

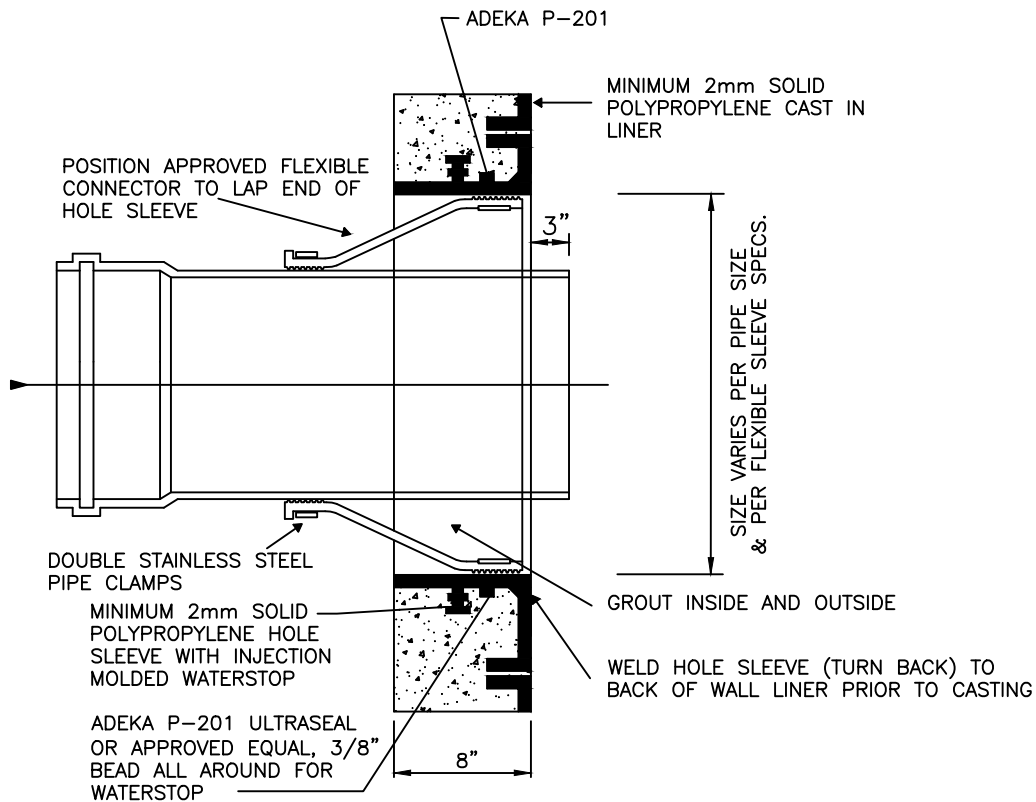

**INSTALLATION:**

- 1) CLEAN BOOT HUB
- 2) INSTALL RUBBER BOOT CONNECTOR (PER MANUFACTURER'S INSTRUCTIONS).
- 3) LUBRICATE PIPE SPIGOT AND SLIDE INTO RUBBER BOOT CONNECTOR.
- 4) TIGHTEN RUBBER BOOT CLAMPS (PER MANUFACTURER'S INSTRUCTIONS)
- 5) SECURE AND BACKFILL WITH PROPER MATERIAL AS SPECIFIED
- 6) CHECK FOR WATERTIGHT CONNECTION

DO NOT LUBRICATE THE BOOT CONNECTOR OR THE BOOT HUB

**NOTES:**

- 1) MANHOLE SHOP DRAWINGS SHALL IDENTIFY THE TYPE OF MANHOLE/PIPE CONNECTION.
- 2) MANHOLE SHOP DRAWINGS SHALL IDENTIFY THE PIPE SIZE, TYPE, GASKET TYPE, AND HOLE SIZE.
- 3) ONLY THE POLYISOPRENE GASKET SUPPLIED BY THE BELL MANUFACTURER SHALL BE USED IN COMPRESSION TYPE BELLS.
- 4) GASKET GLAND VARIES ACCORDING TO PIPE SIZE AND TYPE.
- 5) HOLE SLEEVES AND BELL CONNECTORS SHALL EXTEND TO THE OUTER PROFILE OF THE CONCRETE STRUCTURE AT MINIMUM PROVIDING A COMPLETELY LINED SURFACE WHERE THE GASKET AND HOLE LINER MATE TOGETHER.

TURN BACK BOOT HUB WITH BOOT CONNECTOR

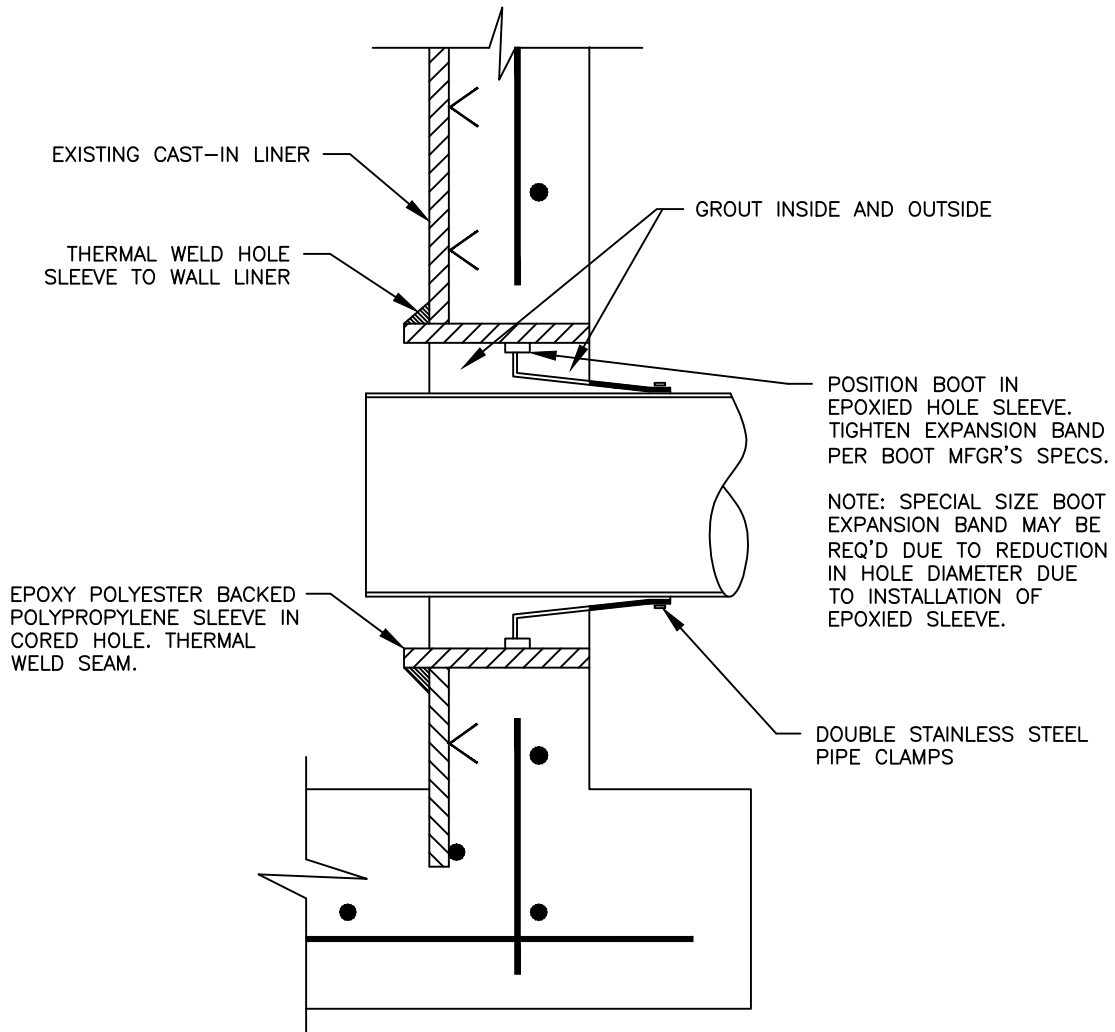

NOTE:  
THERMAL WELDING AND EPOXY OF THE SLEEVE TO  
BE PERFORMED BY A CONTRACTOR CERTIFIED BY  
THE LINER MANUFACTURER

PALM BEACH COUNTY CONSTRUCTION STANDARDS & DETAILS

REVISION/ISSUE DATE  
6/2019

CORED HOLE W/ FLEX. CONNECTOR & TURNBACK  
SLEEVE POLYPROPYLENE LINER SYSTEM CAST-IN

PAGE NO.  
24S

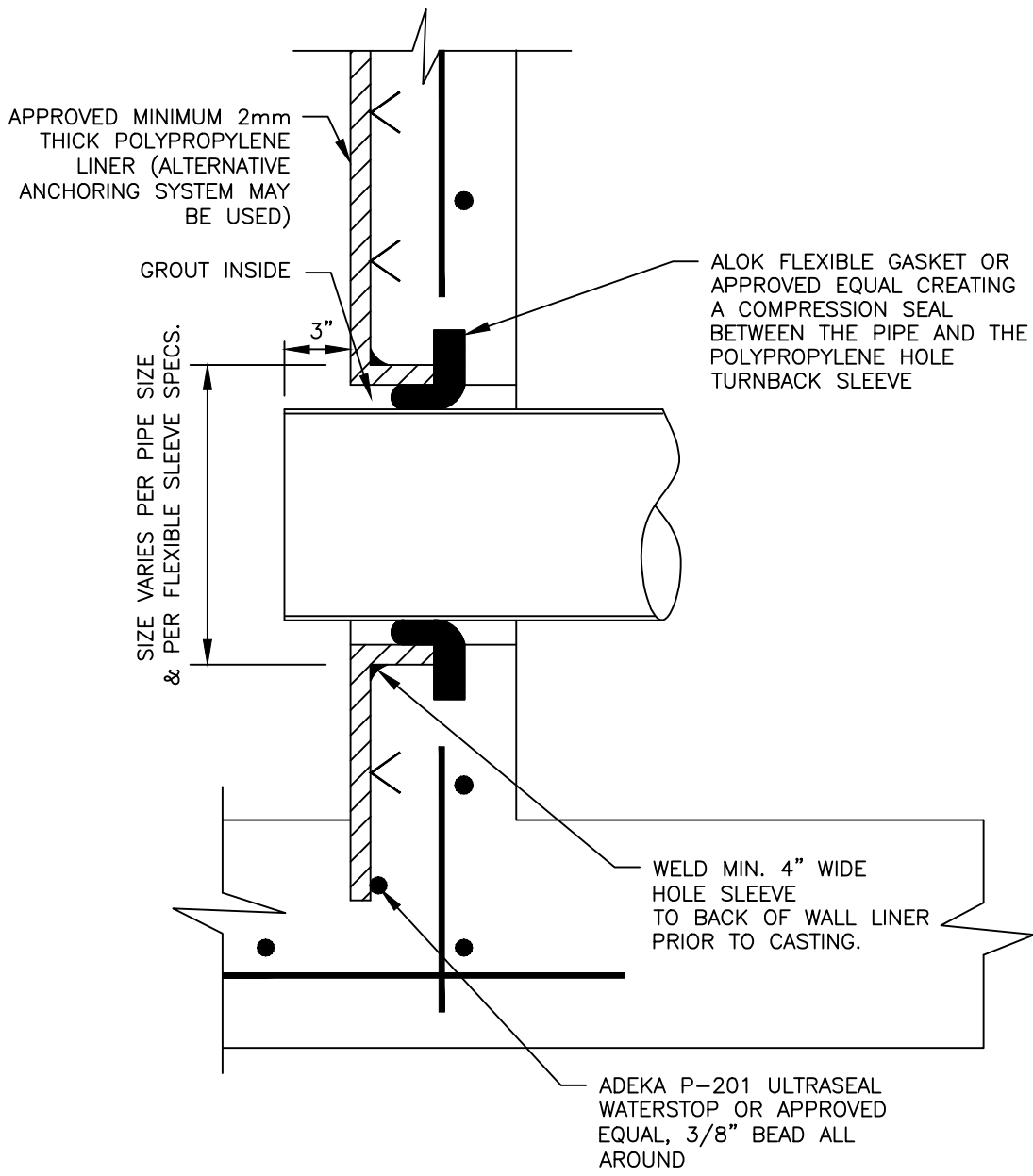

PALM BEACH COUNTY CONSTRUCTION STANDARDS & DETAILS

REVISION/ISSUE DATE

6/2019

PIPE TO DROP MANHOLE CONNECTION  
LOWER INVERT

PAGE NO.

25S

APPROVED MINIMUM 2mm  
THICK POLYPROPYLENE  
LINER (ALTERNATIVE  
ANCHORING SYSTEM MAY  
BE USED)

ADEKA P-201 ULTRA SEAL  
HYDROPHILIC WATERSTOP  
OR APPROVED EQUAL  
3/8" BEAD ALL AROUND

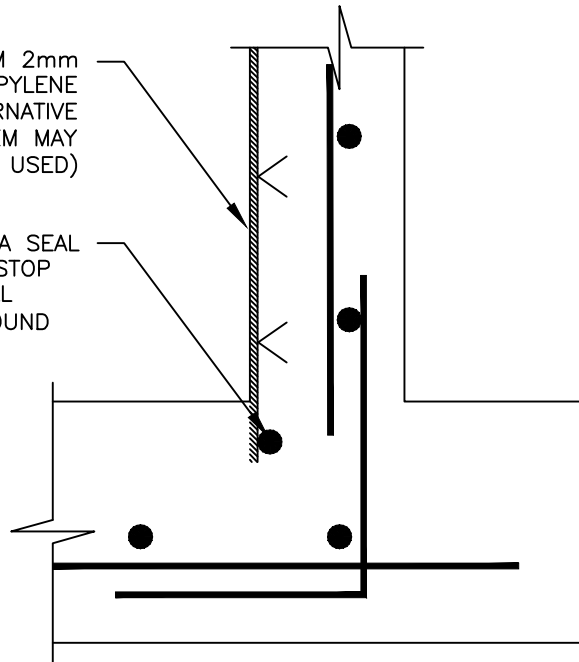

NOTE:  
THIS STYLE WATERSTOP IS USED ON STRUCTURES CAST WITH A  
MONOLITHICALLY POURED BOTTOM SLAB.

PALM BEACH COUNTY CONSTRUCTION STANDARDS & DETAILS

REVISION/ISSUE DATE

6/2019

BASE MANHOLE SECTION WATERSTOP DETAIL

PAGE NO.

26S

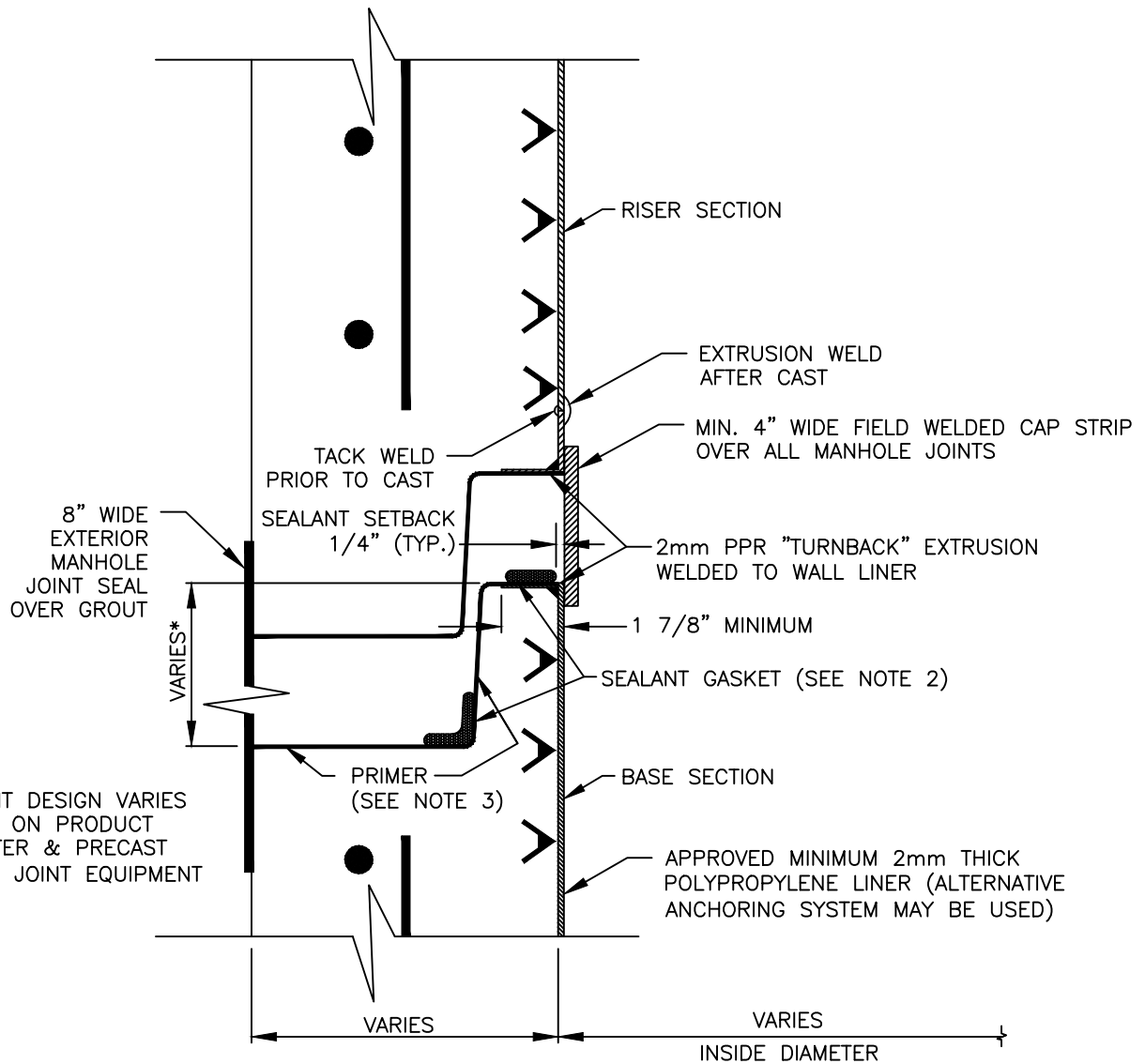

NOTES:

1. LINER WELDING SHALL BE PERFORMED EXCLUSIVELY BY LICENSED, CERTIFIED WELDERS.
2. STRUCTURE SHOP DRAWINGS SHALL CALL OUT THE SIZE, TYPE AND PLACEMENT OF THE JOINT SEALANT.
3. JOINT PRIMER TO BE APPLIED BY THE PRECASTER (TONGUE SECTION ONLY).

PALM BEACH COUNTY CONSTRUCTION STANDARDS & DETAILS

REVISION/ISSUE DATE

6/2019

TURN BACK JOINT INSTALLED PRIOR TO CAST

PAGE NO.

27S

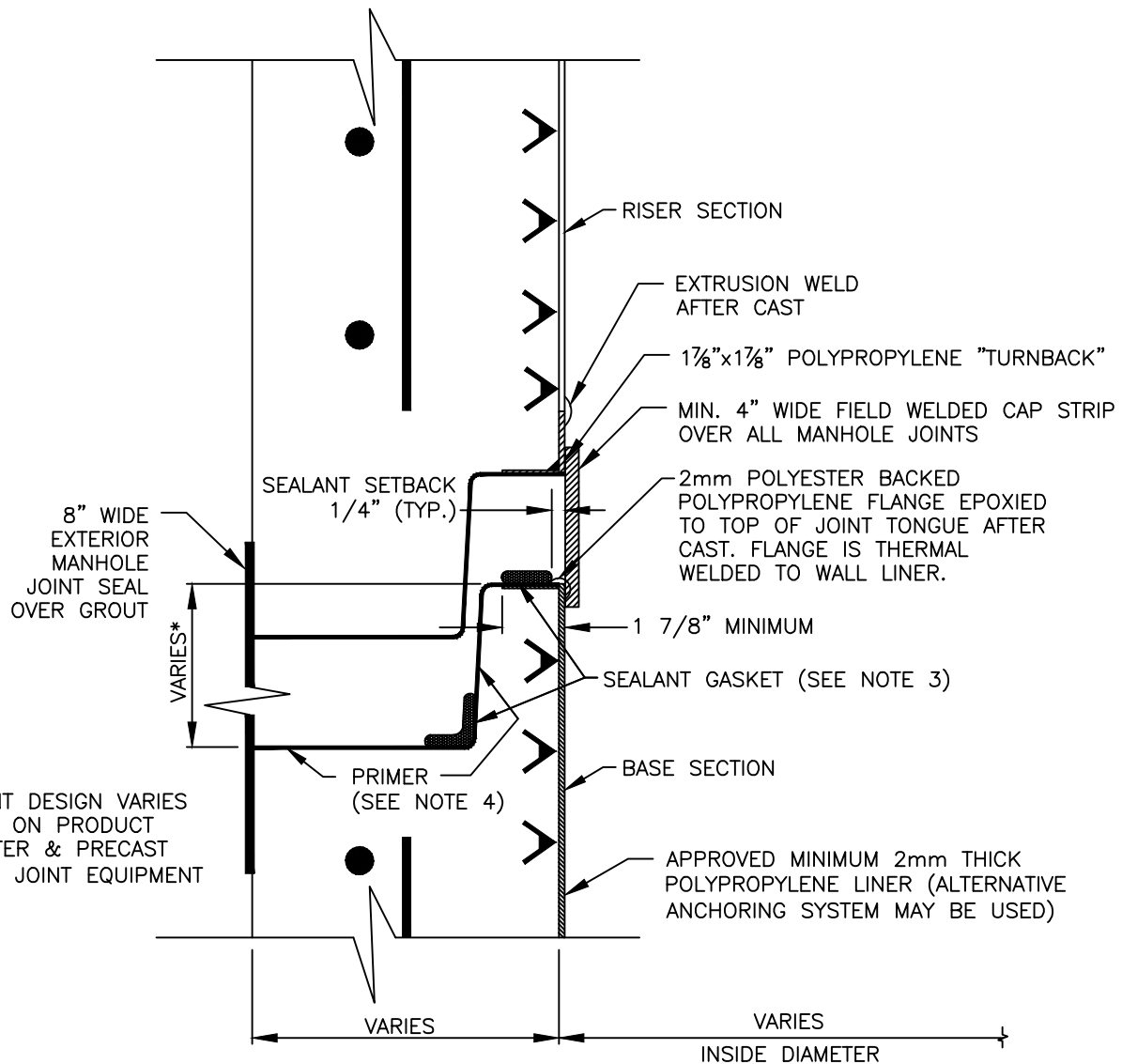

\* JOINT DESIGN VARIES  
BASED ON PRODUCT  
DIAMETER & PRECAST  
MFG.'S JOINT EQUIPMENT

NOTES:

1. THE "AFTER CAST" "TURNBACK" JOINT IS USED WHEN THE "PRIOR TO CAST" "TURNBACK" JOINT IS NOT FEASIBLE.
2. LINER WELDING SHALL BE PERFORMED EXCLUSIVELY BY LICENSED, CERTIFIED WELDERS.
3. STRUCTURE SHOP DRAWINGS SHALL CALL OUT THE SIZE, TYPE AND PLACEMENT OF THE JOINT SEALANT.
4. JOINT PRIMER TO BE APPLIED BY THE PRECASTER (TONGUE SECTION ONLY).

PALM BEACH COUNTY CONSTRUCTION STANDARDS & DETAILS

REVISION/ISSUE DATE

6/2019

TURN BACK JOINT INSTALLED AFTER CAST

PAGE NO.

28S



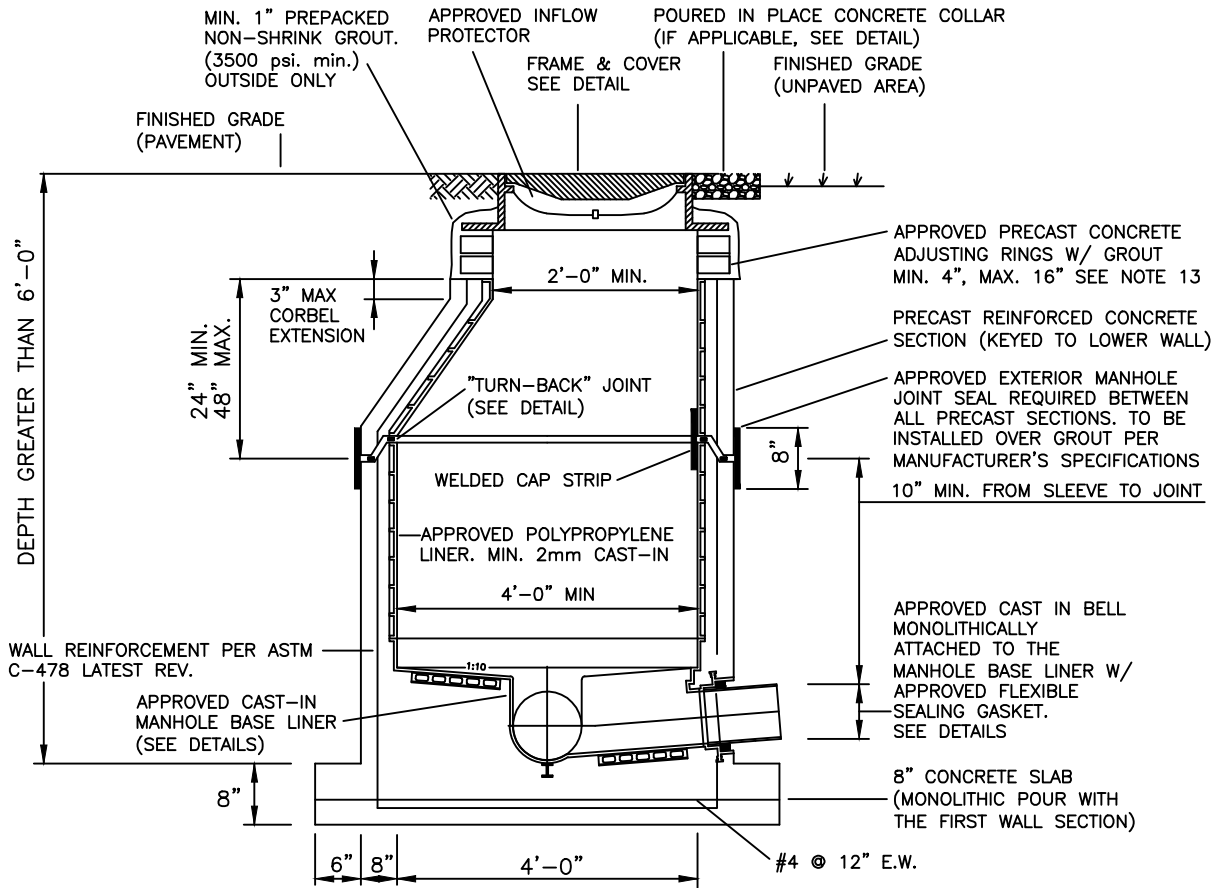

**NOTES:**

1. PRECAST CONCRETE TYPE II 4000 P.S.I. CALCAREOUS AGGREGATE REQUIRED (MIN. CaCO<sub>3</sub> CONTENT: 65% IN LARGE AGGREGATE, 50% IN CONCRETE SCREENING).
2. RUB'R NEK (RU 106) OR APPROVED EQUAL AT ALL RISER JOINTS. SIZES TO BE SPECIFIED ON SHOP DRAWINGS.
3. ALL PIPE OPENINGS SHALL BE GAS TIGHT AND WATER TIGHT WITH NO EXPOSED CONCRETE SURFACES.
4. CAST OPENINGS SHALL BE MANUFACTURED WITH A POLYPROPYLENE SLEEVE CAST IN. APPROVED FLEXIBLE MANHOLE CONNECTORS SHALL BE USED AT PIPE CONNECTIONS. HOLE SIZE PER BOOT MANUFACTURER'S SPECIFICATIONS. DOUBLE PIPE CLAMPS MUST BE INSTALLED ON FLEXIBLE SLEEVES WHERE REQUIRED BY BOOT MANUFACTURER'S INSTALLATION INSTRUCTIONS.
5. CORED PIPE OPENINGS SHALL BE INSTALLED PER DETAIL. APPROVED FLEXIBLE CONNECTOR WILL BE INSTALLED ONTO POLYPROPYLENE WALL SLEEVE. WALL SLEEVE SHALL BE EPOXIED INTO CORED OPENING AND THERMAL WELDED TO WALL LINER. BY LICENSED CONTRACTOR.
6. FLOW CHANNELS SHALL DIRECT INFLUENT INTO FLOW STREAM. (SEE DETAIL)
7. LIFT HOLES ARE PERMITTED.
8. INSIDE DROPS SHALL NOT BE DESIGNED TO EXCEED 1.80 FEET AND NOT CONSTRUCTED TO EXCEED 2.0 FEET. MAX. 6" INSIDE DROP IS PERMITTED FOR MANHOLES WITH 3 OR MORE INVERTS AND MANHOLES WITH A CHANGE IN FLOW DIRECTION OF MORE THAN 45 DEGREES.
9. MANHOLE FABRICATION SHALL BE IN ACCORDANCE WITH ASTM C-478, LATEST STANDARD.
10. MINIMUM 5 FEET IS REQUIRED BETWEEN OUTSIDE OF MANHOLE AND SERVICE WYE.
11. MANHOLES SHALL BE LINED INSIDE WITH AN APPROVED POLYPROPYLENE LINER SYSTEM. LINERS MUST BE WELDED BY LINER MFG CERTIFIED WELDERS AND BE CAST INTO THE MANHOLE BY A LINER MANUFACTURER CERTIFIED PRECASTER.
12. APPROVED INFLOW PROTECTORS ARE REQUIRED.
13. MAXIMUM HEIGHT OF CHIMNEY SHALL NOT EXCEED 24" (INCLUDING FRAME CASTING).
14. APPROVED THERMO-PLASTIC CHIMNEY LINER SHALL COMPLETELY COVER THE PRECAST CONCRETE GRADE RINGS AND SHALL BE SEALED TO THE CORBEL LINER BY MEANS OF AN APPROVED POLYISOPRENE LIP SEAL GASKET AND SEALED TO THE RING USING APPROVED BUTYL STRIPS. SEE DETAILS.
15. SOLID THERMO-PLASTIC CAST-IN LINER SYSTEM IS REQUIRED FOR LAST MANHOLE PRIOR TO A LIFT STATION, MANHOLES DEEPER THAN 14 FEET, MANHOLES WITH AN OUTSIDE DROP, AND MANHOLES WITH A FORCE MAIN CONNECTION. SEE APPROPRIATE DETAILS.
16. MANHOLES IN ROADWAYS SHALL BE LOCATED OUTSIDE OF WHEEL PATHS.

PALM BEACH COUNTY CONSTRUCTION STANDARDS & DETAILS

REVISION/ISSUE DATE

6/2019

STANDARD MANHOLE WITH CAST-IN LINER  
AND BASE LINER

PAGE NO.

295

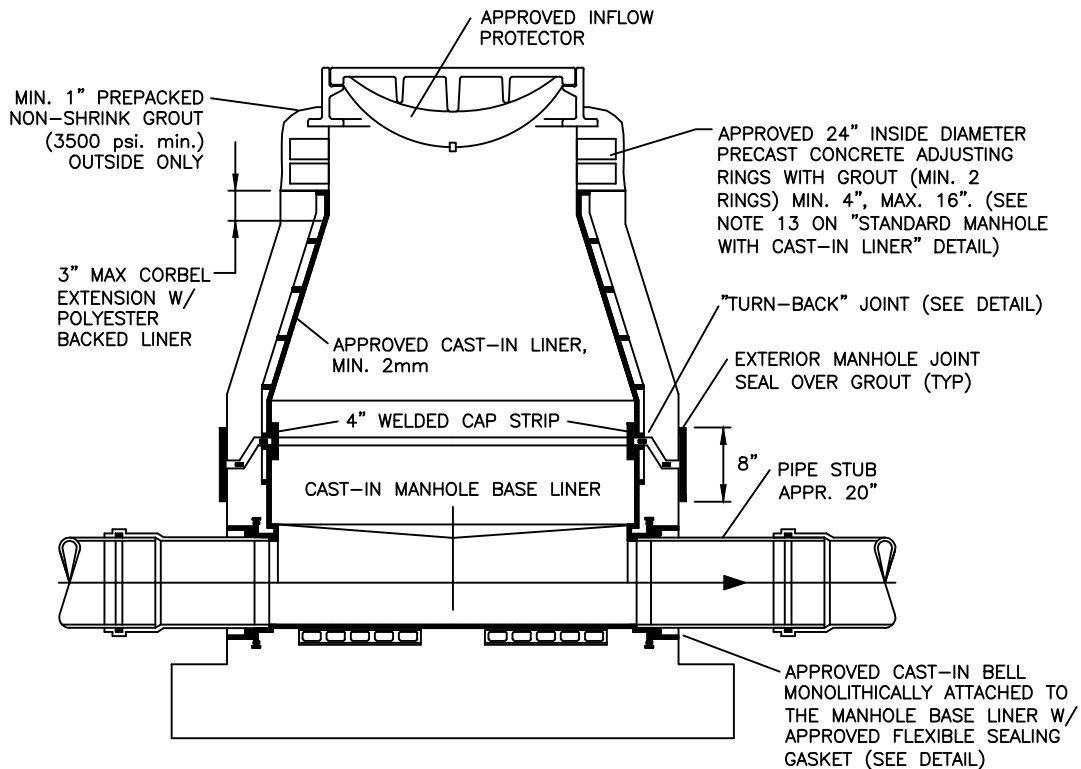
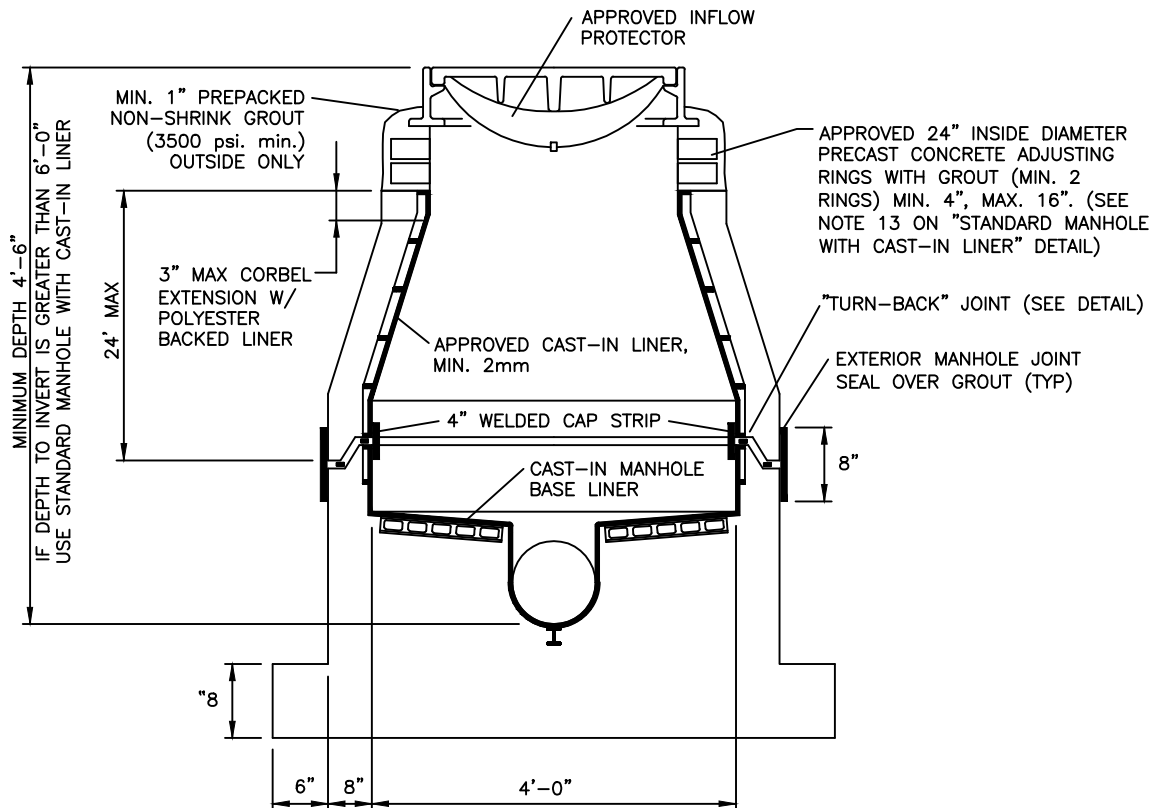

NOTE: ALL CORRESPONDING STANDARD MANHOLE NOTES AND DETAILS SHALL APPLY.

PALM BEACH COUNTY CONSTRUCTION STANDARDS & DETAILS

REVISION/ISSUE DATE

6/2019

SHALLOW MANHOLE WITH CAST-IN LINER  
AND BASE LINER

PAGE NO.

30S

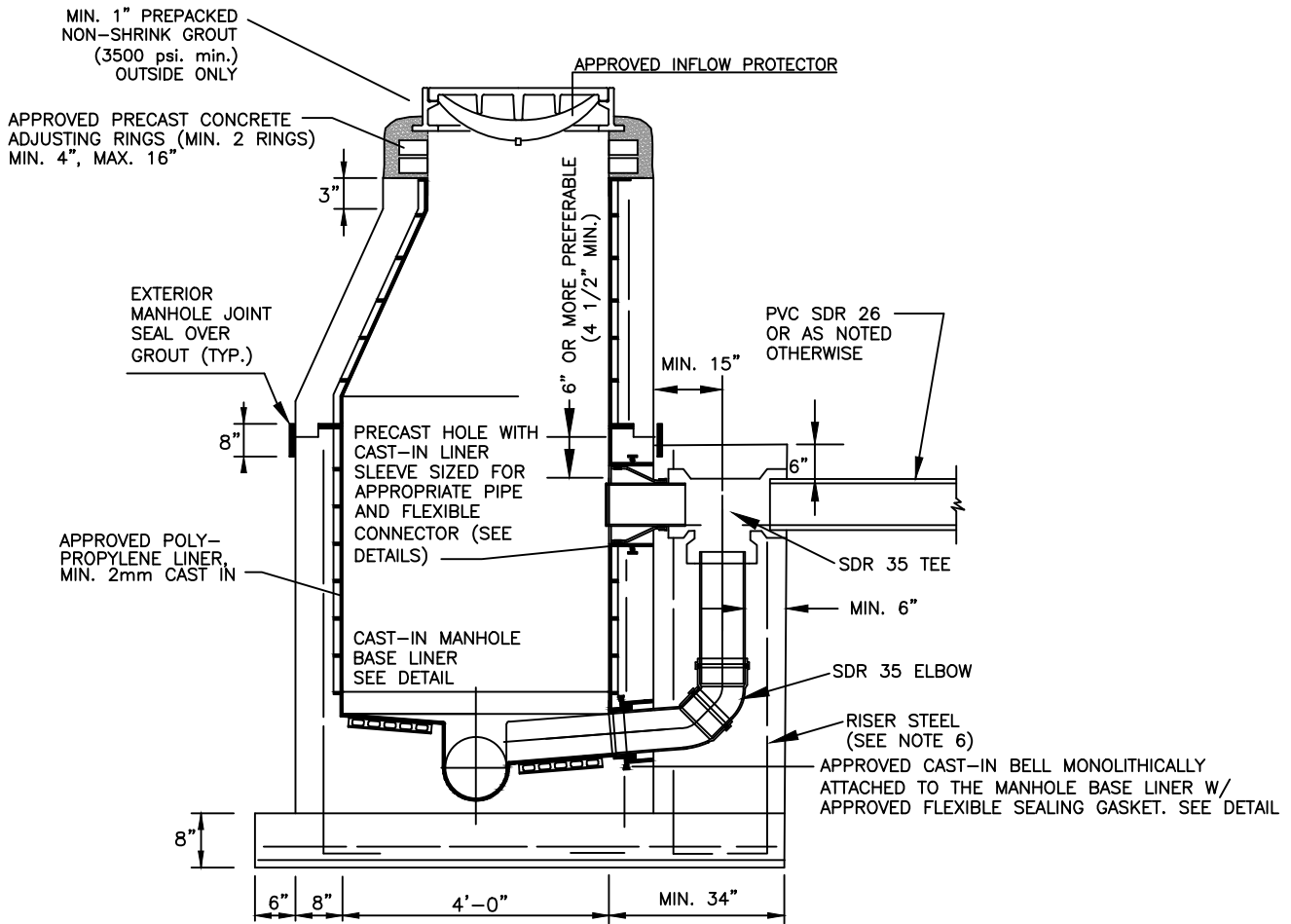

**NOTES:**

1. ALL DETAILS AND SPECIFICATIONS FOR "STANDARD MANHOLE WITH SOLID POLYPROPYLENE LINER SYSTEM" ARE APPLICABLE EXCEPT FOR REFERENCES TO DROP ASSEMBLY.
2. THE PRECAST BASE SHALL EXTEND FULLY UNDER THE DROP ASSEMBLY.
3. PRECAST DROP ENCASMENT REQUIRED UP TO TOP EDGE OF 90 DEGREE ELBOW, BRICK AND CONCRETE RUBBLE ARE PERMITTED AS FILLER IN REMAINDER OF DROP ENCASMENT.
4. DROP CONNECTIONS SHALL BE REQUIRED WHENEVER AN INFLUENT INVERT IS LOCATED 2.0 FEET OR MORE ABOVE THE MAIN INVERT CHANNEL. DROP CONNECTIONS SHOULD NOT BE DESIGNED FOR LESS THAN A 2.4 FOOT DROP.
5. PVC SDR 26 PIPE WITH PVC SDR 35 FITTINGS SHALL BE UTILIZED IN THE DROP ASSEMBLY.
6. DROP ENCASMENT REINFORCING STEEL TO BE CAST IN PLACE WITH BASE (4 RODS) OR USE 4-1/2" DIA. COIL LOOP INSERTS CAST IN PLACE WITH BASE (TO BE USED WITH 1/2" COIL RODS). COIL LOOP INSERTS TO BE "DAYTON SUPERIOR" B16, 1/2"X 4" OR APPROVED EQUAL.

PALM BEACH COUNTY CONSTRUCTION STANDARDS & DETAILS

REVISION/ISSUE DATE

6/2019

OUTSIDE DROP MANHOLE WITH CAST-IN LINER  
AND BASE LINER

PAGE NO.

31S

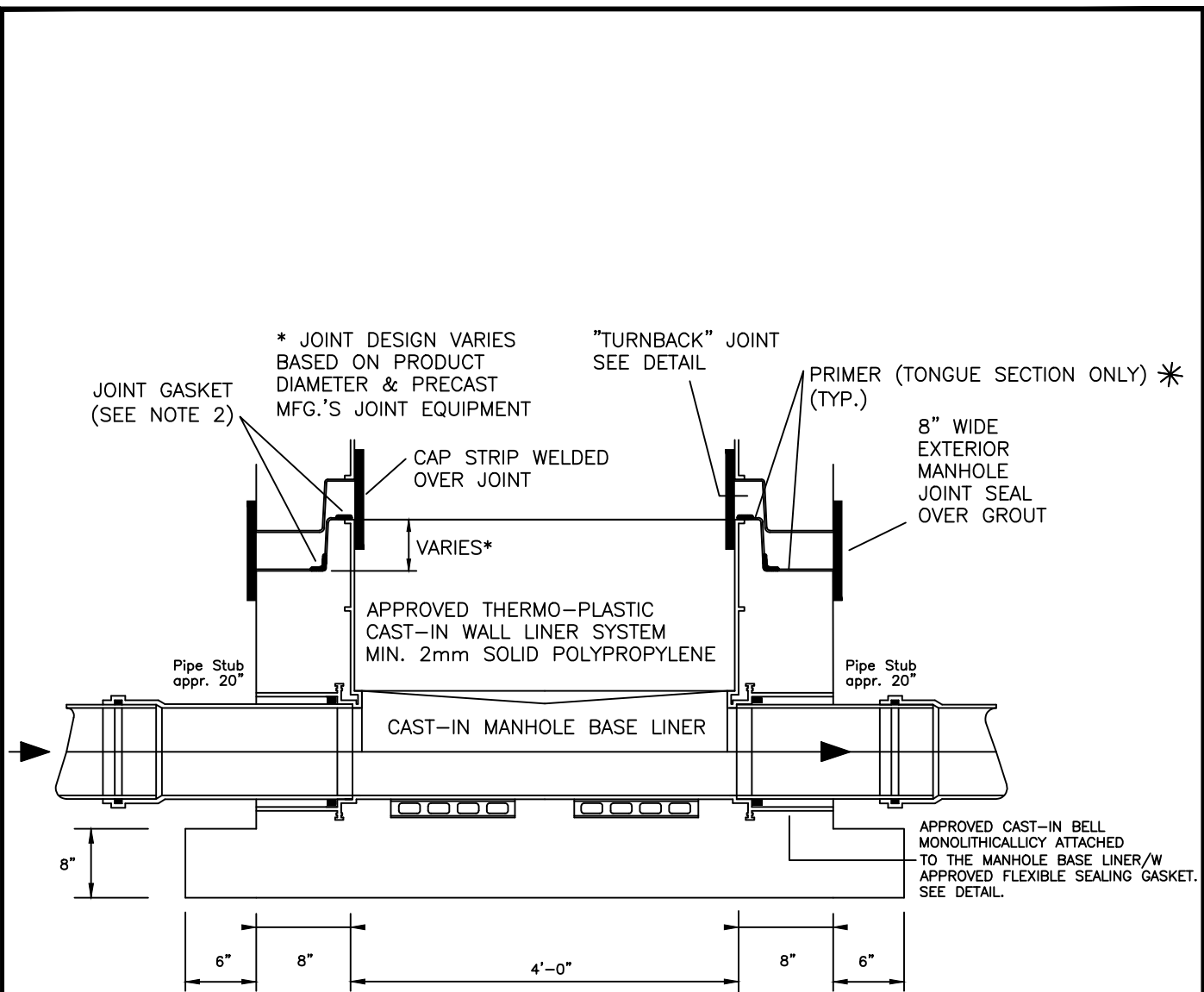

NOTES:

1. LINER WELDING SHALL BE PERFORMED EXCLUSIVELY BY LICENSED, CERTIFIED WELDERS.
2. SHOP DRAWINGS SHALL CALL OUT THE SIZE, TYPE AND POSITIONING OF THE APPROVED JOINT SEALANT.
3. PRIMER TO BE APPLIED BY THE PRECASTER (TONGUE SECTION ONLY).

PALM BEACH COUNTY CONSTRUCTION STANDARDS & DETAILS

REVISION/ISSUE DATE

6/2019

MANHOLE BASE SECTION

PAGE NO.

32S

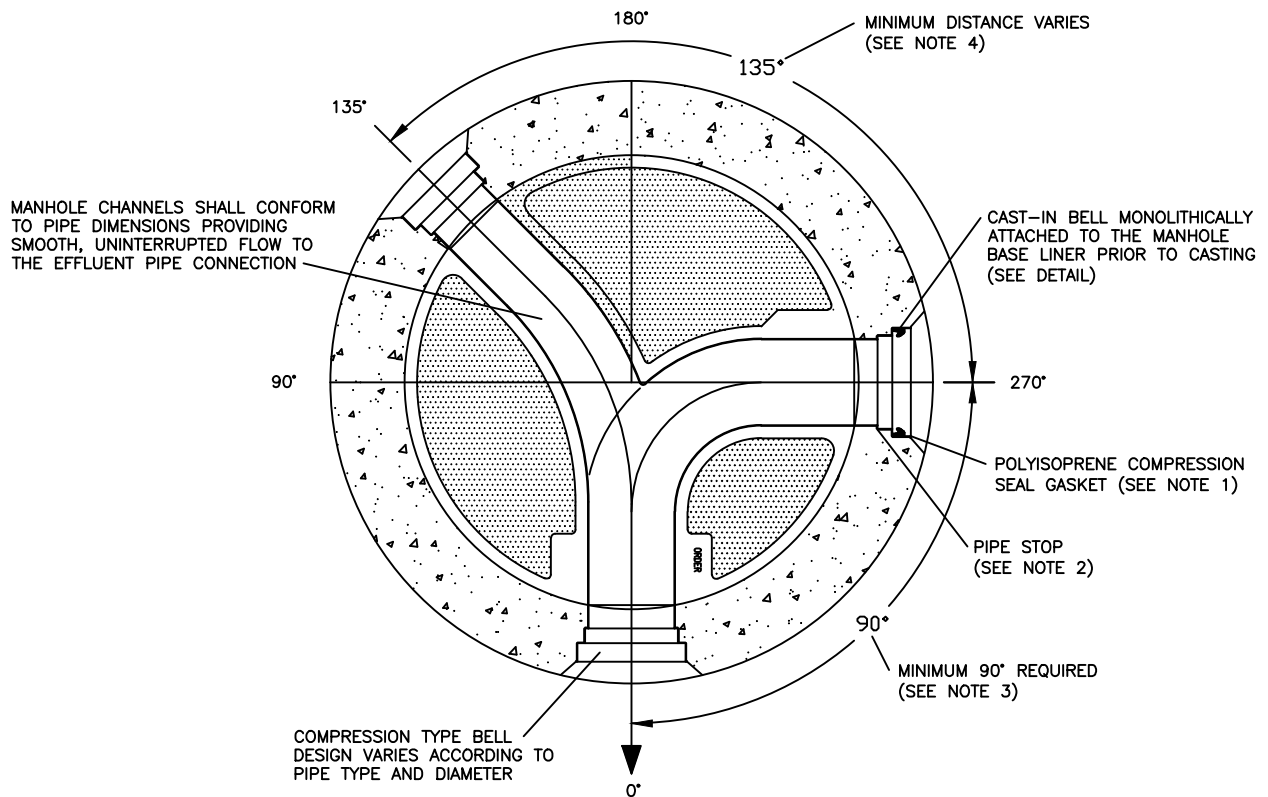

NOTES:

1. ONLY THE POLYISOPRENE GASKET PROVIDED BY THE MANHOLE BASE LINER MANUFACTURER SHALL BE USED IN COMPRESSION TYPE BELLS.
2. CONNECTION PIPES SHALL BE INSERTED COMPLETELY INTO THE BELL CONNECTOR FLUSH WITH THE PIPE STOP PROVIDING A SMOOTH TRANSITION FROM PIPE TO MANHOLE BASE LINER CHANNEL.
3. MINIMUM OF 90 DEGREES BETWEEN INCOMING, LEFT OR RIGHT OF OUTGOING PIPE. DISTANCE BETWEEN CONNECTIONS MAY VARY ACCORDING TO MANHOLE DIAMETER, PIPE SIZE AND TYPE.
4. MINIMUM DISTANCE BETWEEN INFLUENT PIPE CONNECTIONS MAY VARY AND SHALL BE SPECIFIED BY THE LINER MANUFACTURER ACCORDING TO MANHOLE AND/OR PIPE DIAMETER AND TYPE.

PALM BEACH COUNTY CONSTRUCTION STANDARDS & DETAILS

REVISION/ISSUE DATE

6/2019

FLOW CHANNEL/PIPE CONNECTION  
TO NEW CAST-IN BASE LINER

PAGE NO.

335

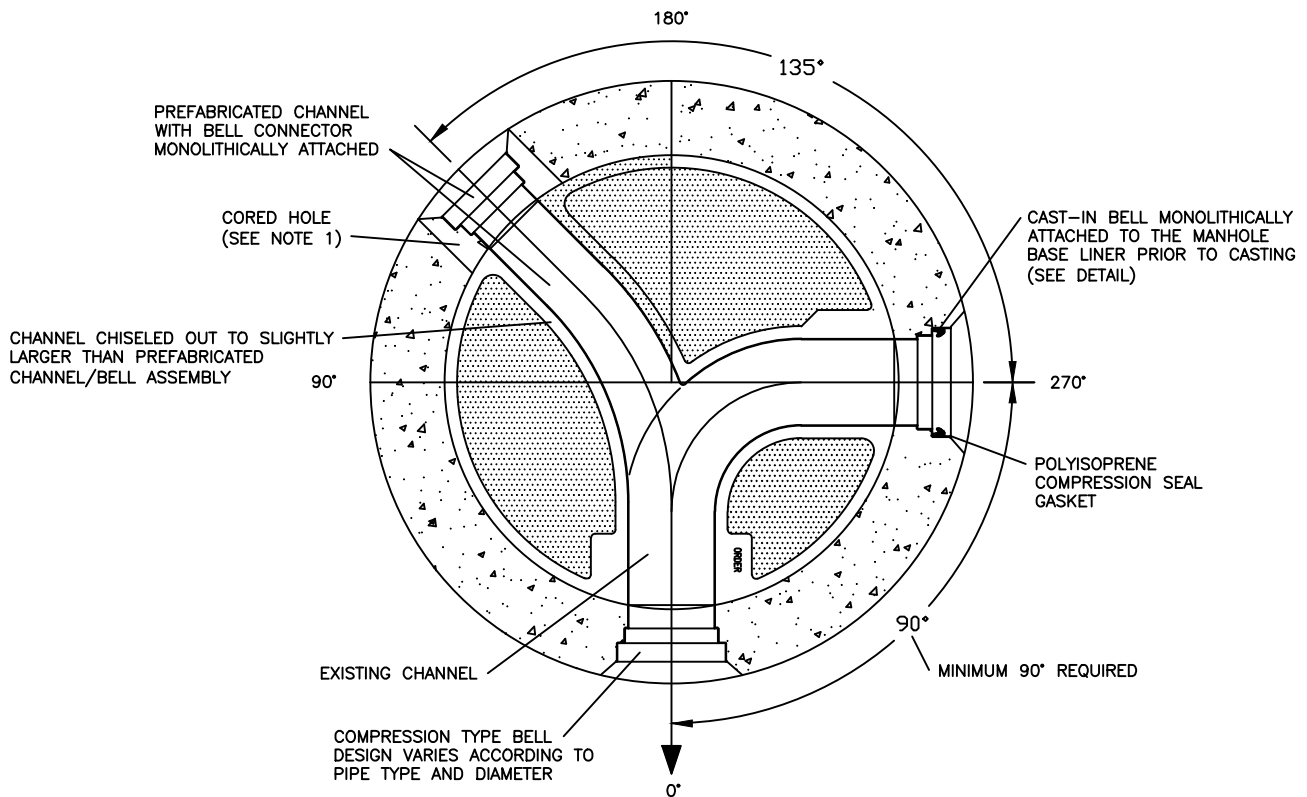

NOTES:

1. CORED OPENING AND CHANNEL DIAMETER PER CHANNEL/BELL MANUFACTURER REQUIREMENTS. SIZES SHALL BE SPECIFIED ON SHOP DRAWING.
2. ONLY AN APPROVED CHANNEL/BELL ASSEMBLY PROVIDED BY THE BASE LINER MANUFACTURER SHALL BE USED.
3. CHANNEL/BELL ASSEMBLY MUST BE COMPLETELY GROUTED IN PLACE USING AN APPROVED CEMENT.
4. UPON "SETTING" OF GROUT, THE NEW CHANNEL/BELL ASSEMBLY MUST BE JOINED TO THE EXISTING MANHOLE BASE LINER BY EITHER THERMO-PLASTIC WELDING OR FRP PATCH AS SPECIFIED BY BASE LINER MANUFACTURER.

PALM BEACH COUNTY CONSTRUCTION STANDARDS & DETAILS

REVISION/ISSUE DATE

6/2019

FLOW CHANNEL/ PIPE CONNECTION  
TO EXISTING CAST-IN BASE LINER

PAGE NO.

34S

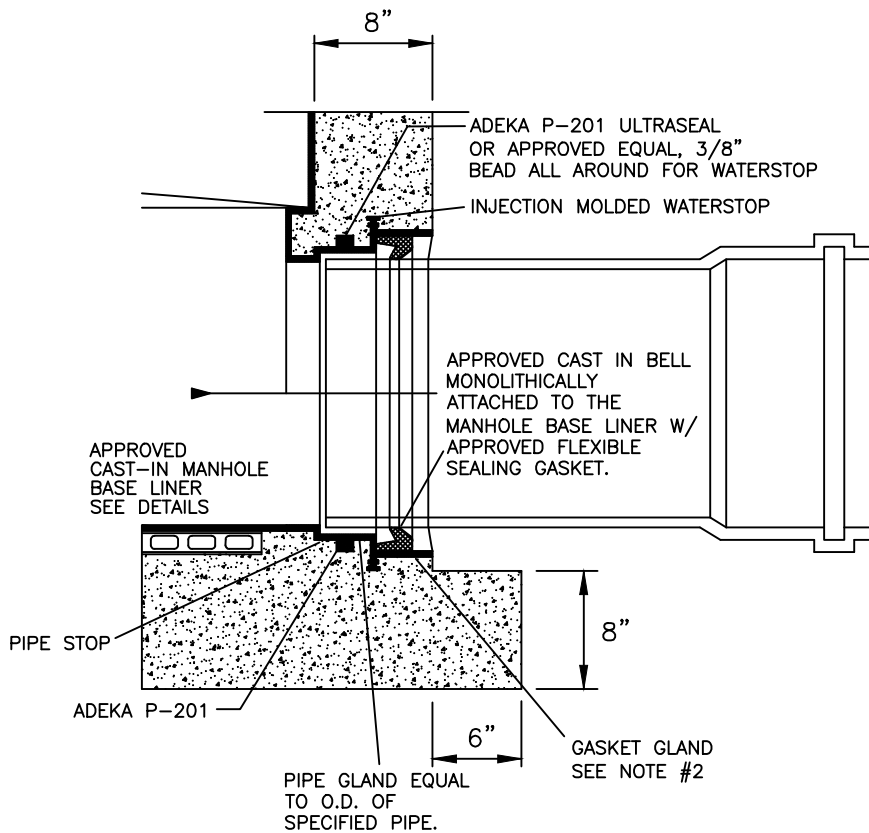

**INSTALLATION:**

1. CLEAN BELL REMOVING ANY EXCESS CONCRETE SLURRY OR DIRT INSIDE BELL.
2. INSTALL GASKET AS SHOWN.
3. LUBRICATE PIPE SPIGOT AND SLIDE INTO BELL AND GASKET UNTIL REACHING PIPE STOP.
4. CHECK FOR WATERTIGHT CONNECTION. (VACUUM TESTING OR OTHER APPROVED METHOD).

DO NOT LUBRICATE THE GASKET OR THE BELL

**NOTES:**

1. MANHOLE SHOP DRAWINGS SHALL IDENTIFY THE TYPE OF MANHOLE/PIPE CONNECTION.
2. ONLY THE POLYISOPRENE GASKET SUPPLIED BY THE BELL MANUFACTURER SHALL BE USED IN COMPRESSION TYPE BELLS.
3. BOOT HUB VARIES ACCORDING TO GASKET MANUFACTURER'S SPECIFICATION FOR SPECIFIC PIPE SIZE AND TYPE.
4. MANHOLE SHOP DRAWINGS MUST IDENTIFY THE PIPE SIZE, TYPE, GASKET TYPE AND HOLE SIZE.

PALM BEACH COUNTY CONSTRUCTION STANDARDS & DETAILS

REVISION/ISSUE DATE

6/2019

PIPE TO MANHOLE CONNECTION DETAIL  
TYPE "A" (GASKET)

PAGE NO.

35S

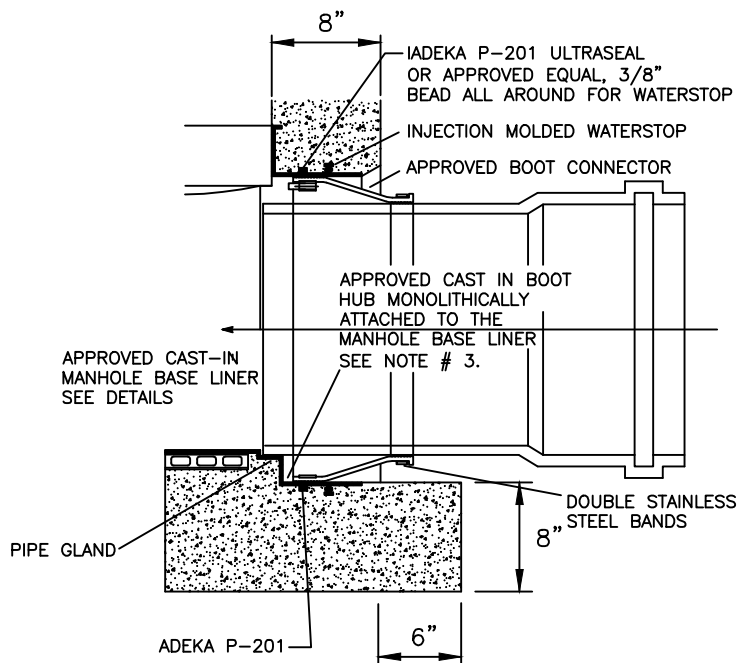

INSTALLATION:

1. CLEAN BOOT HUB REMOVING ANY EXCESS CONCRETE SLURRY OR DIRT INSIDE BELL.
2. INSTALL RUBBER BOOT CONNECTOR (PER MANUFACTURER'S INSTRUCTIONS). WEDGE STYLE EXPANDER BOLTS MUST BE ALIGNED WITH THE "TOP" OF BOOT HUB ACCESS NOTCH.
3. PRE-MITER PIPE END AS REQUIRED TO PREDETERMINED PIPE DEFLECTION ANGLE. MERELY "DE-BURR" PIPE END - DO NOT CHAMFER OR BEVEL PIPE END.
4. LUBRICATE SPIGOT; ORIENT PIPE MITER; SLIDE INTO RUBBER BOOT CONNECTOR; "HOME" PIPE TO BASE LINER CHANNEL END; DEFLECT PIPE AS REQUIRED. INSPECT MANHOLE BASE INTERIOR FOR CHANNEL/PIPE INVERT ALIGNMENT AND SEAL; TIGHTEN RUBBER BOOT CLAMP (PER MANUFACTURER'S INSTRUCTIONS).
- 1: CHECK FOR WATERTIGHT CONNECTION; (VACUUM TESTING OR OTHER APPROVED METHOD).

DO NOT LUBRICATE THE GASKET OR THE BELL

NOTES:

1. MANHOLE SHOP DRAWINGS SHALL IDENTIFY THE TYPE OF MANHOLE/PIPE CONNECTION.
2. ONLY THE POLYISOPRENE GASKET SUPPLIED BY THE BELL MANUFACTURER SHALL BE USED IN COMPRESSION TYPE BELLS.
3. BOOT HUB VARIES ACCORDING TO GASKET MANUFACTURER'S SPECIFICATION FOR SPECIFIC PIPE SIZE AND TYPE.
4. MANHOLE SHOP DRAWINGS MUST IDENTIFY THE PIPE SIZE, TYPE, GASKET TYPE AND HOLE SIZE.

PALM BEACH COUNTY CONSTRUCTION STANDARDS & DETAILS

REVISION/ISSUE DATE

6/2019

PIPE TO MANHOLE CONNECTION  
TYPE "B" (BOOT)

PAGE NO.

365



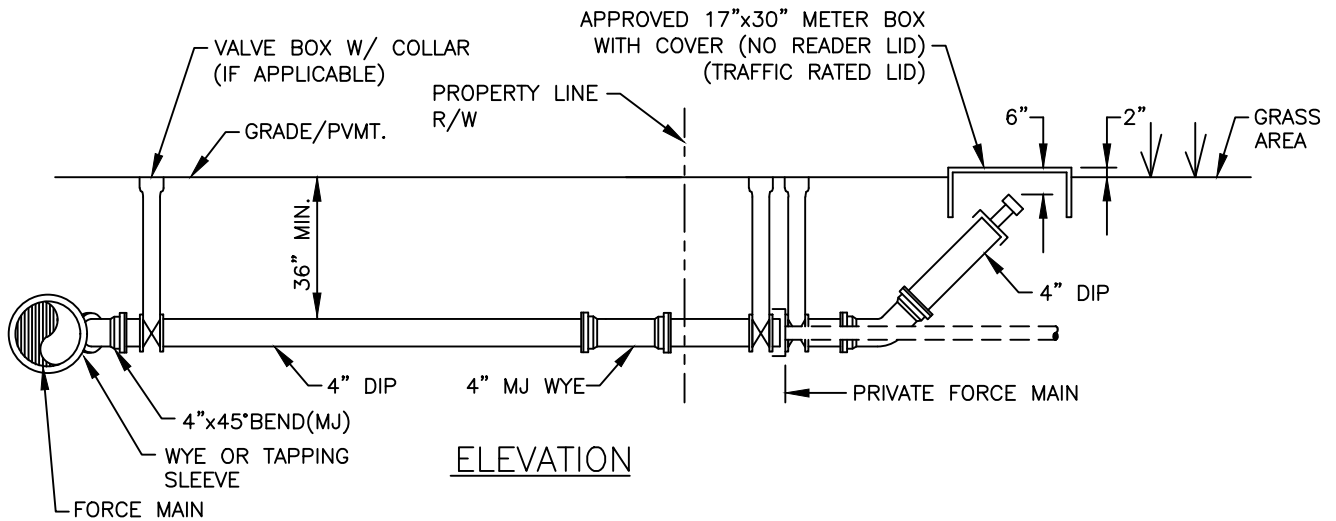
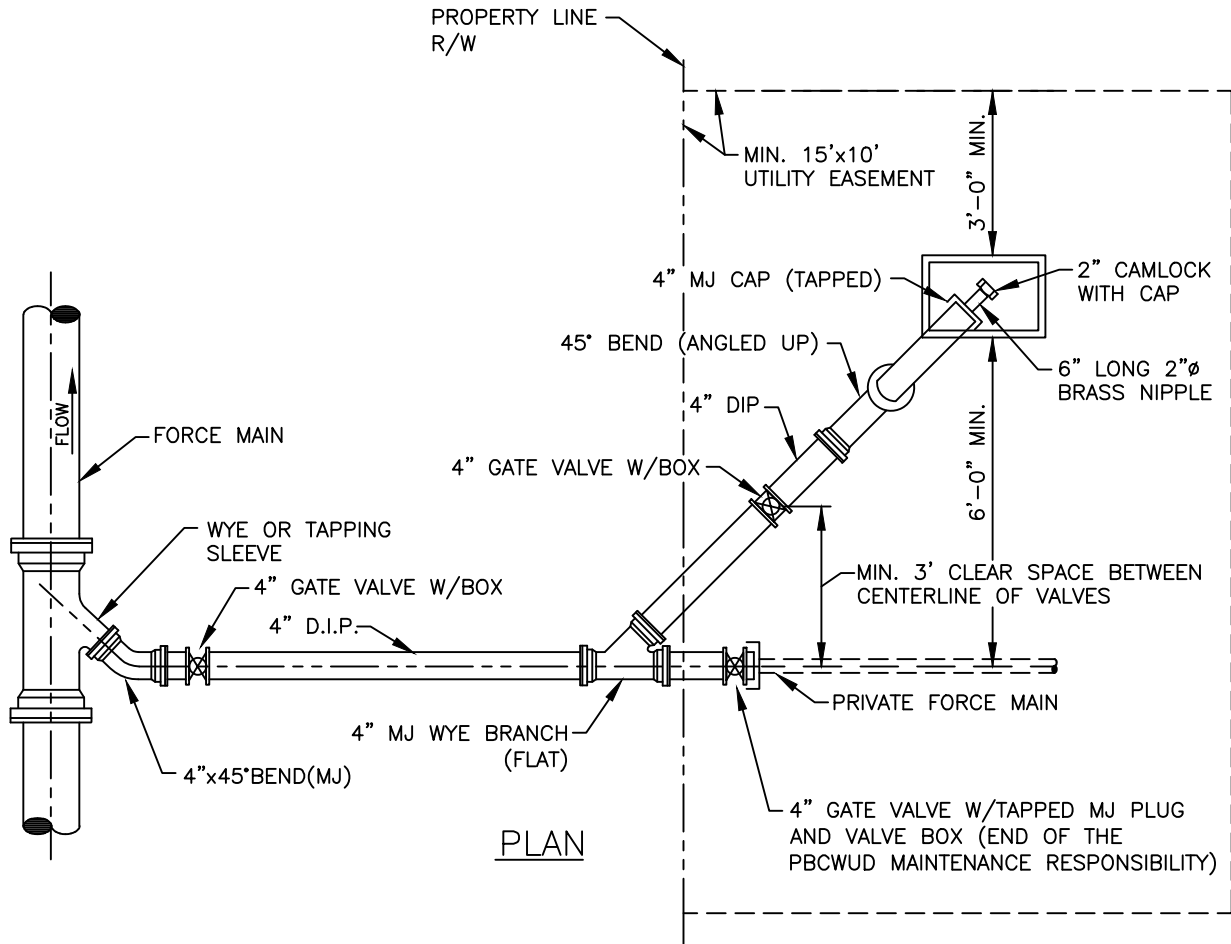

**NOTE:**

1. THE FLUSHING CONNECTION SHALL BE LOCATED IN GRASS AREA.
2. ALL 4" PIPES SHALL BE RESTRAINED.

PALM BEACH COUNTY CONSTRUCTION STANDARDS & DETAILS

REVISION/ISSUE DATE  
6/2019

CONNECTION OF PRIVATE FORCE MAIN UNDER  
4" IN DIAMETER

PAGE NO.  
37S

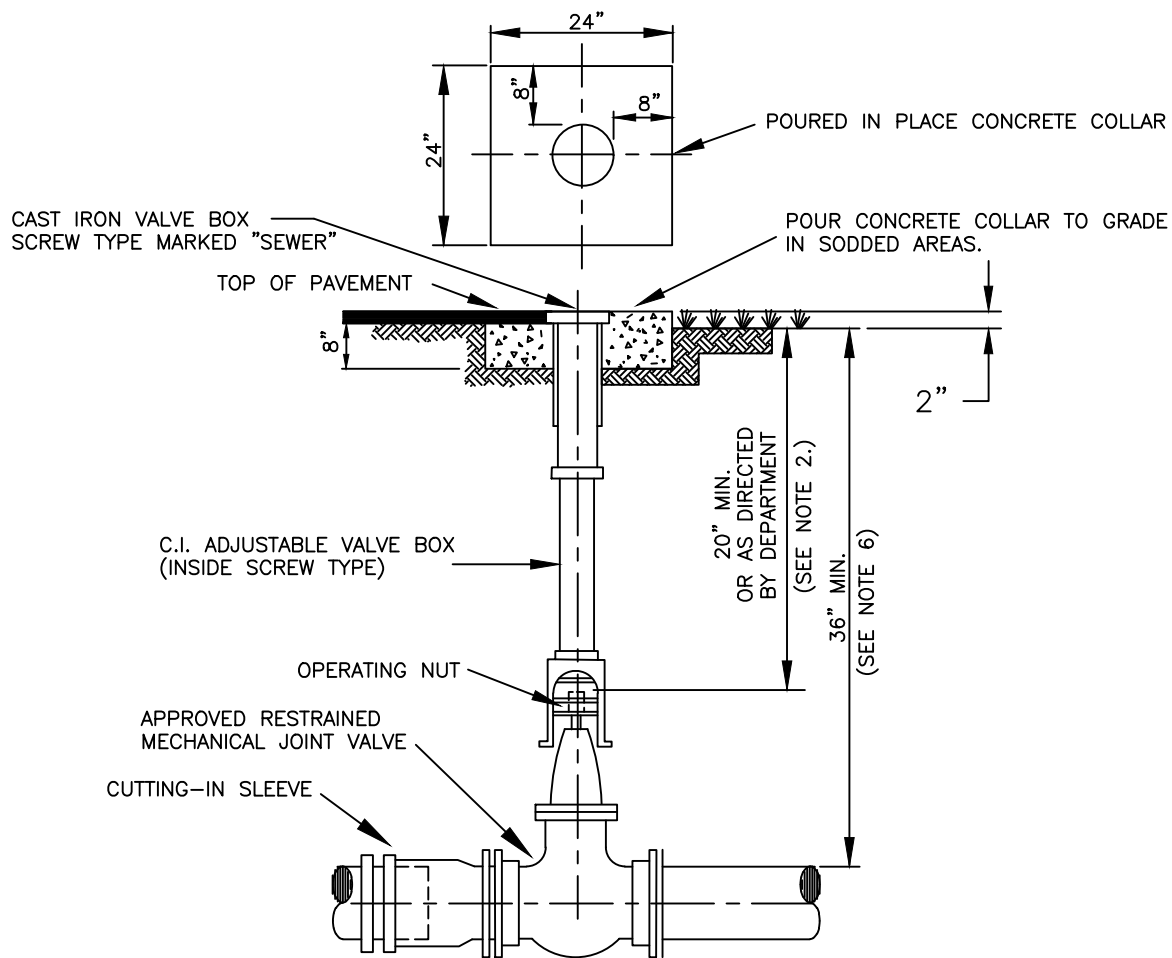

**NOTES:**

1. CONCRETE COLLAR IS NOT REQUIRED IN PAVED AREAS IF PAVEMENT SURFACE IS FINISHED PRIOR TO CONDITIONAL FINAL INSPECTION.
2. WHEN OPERATING NUT IS DEEPER THAN 36" A ONE PIECE EXTENSION WILL BE REQUIRED TO BRING OPERATING NUT 20"-30" BELOW FINISHED GRADE. EXTENSION BOLTS & NUTS ARE TO BE STAINLESS STEEL. A HIGH STRENGTH STEEL CENTERING PLATE, WELDED TO THE EXTENSION, IS ALSO REQUIRED.
3. VALVE BOXES SHALL HAVE COVERS MARKED "SEWER".
4. EXTENSION VALVE BOX TO BE D.I.P. OR C-900 PVC DR 18 (COLOR: GREEN)
5. A CUT-IN INSTALLATION SHALL REQUIRE MEGALUGS OR EQUAL THROUGHOUT ASSEMBLY.
6. IN ORDER TO MAINTAIN ADEQUATE COVER OVER VALVE NUT, THE FOLLOWING MINIMUM COVERS OVER PIPE ARE REQUIRED

<u>GATE VALVE SIZE</u>	<u>MIN. COVER OVER PIPE</u>
16"	48"
20"	54"
24"	60"
30"	72"
36"	84"

7. PIPE SHALL BE RESTRAINED ON BOTH SIDES OF THE VALVE AS REQUIRED.
8. VALVES IN ROADWAYS SHALL BE LOCATED OUTSIDE OF WHEEL PATHS WHENEVER POSSIBLE.

PALM BEACH COUNTY CONSTRUCTION STANDARDS & DETAILS

REVISION/ISSUE DATE

6/2019

TYPICAL FORCE MAIN GATE VALVE SETTING  
AND CUT-IN DETAIL

PAGE NO.

385

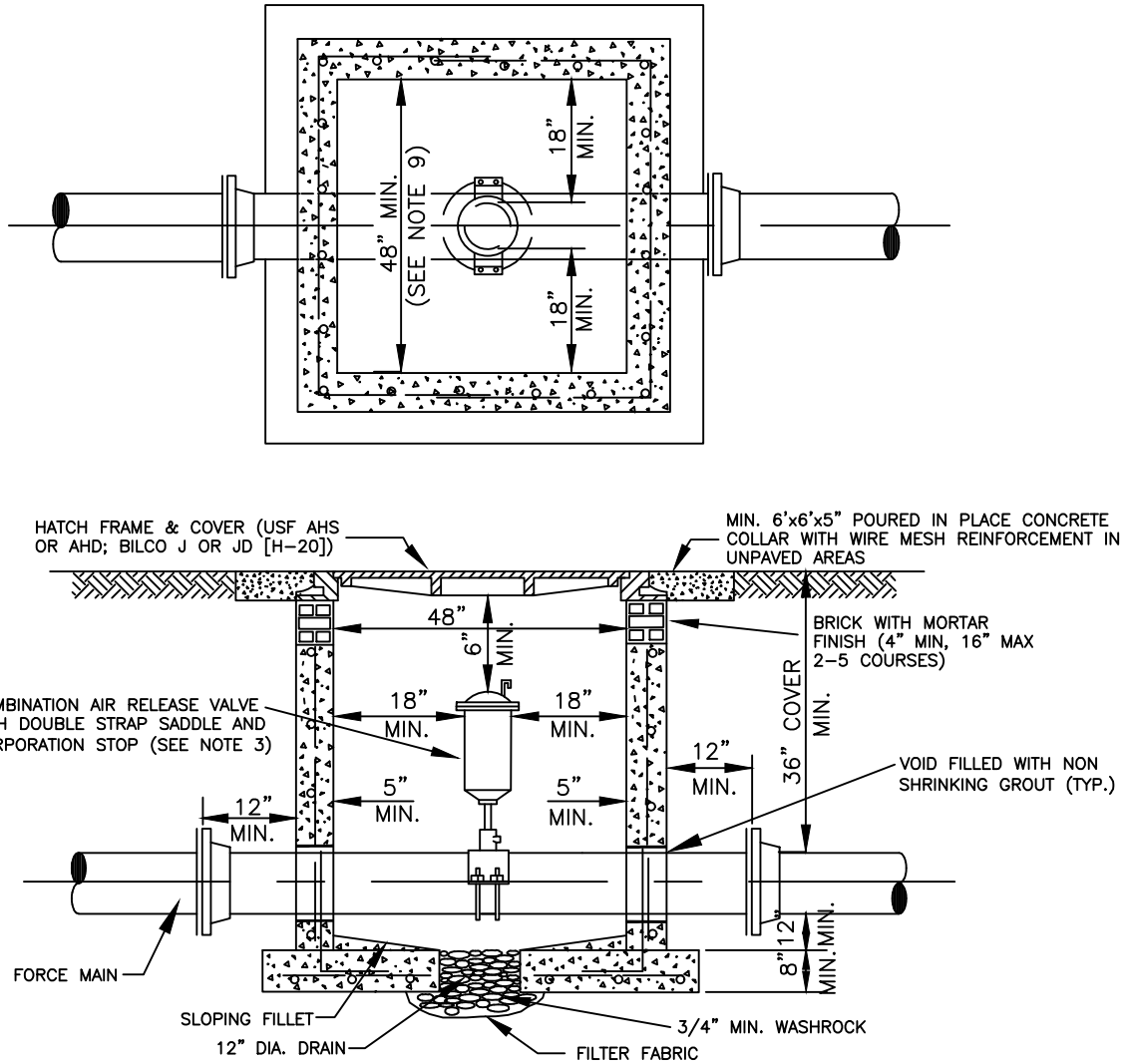

**NOTES:**

1. 4000 P.S.I. TYPE II CONCRETE
2. VAULT SHALL BE PRECAST WITH STEEL REINFORCING. SHOP DRAWING IS REQUIRED TO BE APPROVED BY THE DEPARTMENT PRIOR TO VAULT CONSTRUCTION AND/OR INSTALLATION.
3. COMBINATION AIR RELEASE VALVE (ARV) SHALL BE TYPE AND SIZE APPROPRIATE FOR SERVICE INTENDED. ALTHOUGH A 2" MINIMUM SIZED ARV IS REQUIRED ON FORCE MAIN INSTALLATIONS.
4. ALL OPENINGS SHALL BE SEALED WITH WATERPROOF NON-SHRINKING GROUT.
5. ALTERNATE VAULT AND COVER DESIGN MAY BE USED PROVIDED ALTERNATE VAULT AND/OR COVER SHOP DRAWINGS WERE SUBMITTED AND APPROVED BY THE DEPARTMENT PRIOR TO THE VAULT AND/OR COVER BEING INSTALLED.
6. COAT INSIDE WITH AN APPROVED CORROSION BARRIER SYSTEM.
7. DUCTILE IRON PIPE IS REQUIRED THROUGH THE VAULT. NO PIPE JOINTS WITHIN THE VAULT.
8. THREADED AREAS OF CORPORATION STOP SHALL BE SPIRAL WRAPPED WITH TWO WRAPS OF TEFLON TAPE.
9. LARGER VAULTS WILL BE REQUIRED FOR PIPES LARGER THAN 12"

PIPE SIZE	MIN. VAULT SIZE
16"-24"	4'W x 5'L
30"-42"	4'W x 6'L

PALM BEACH COUNTY CONSTRUCTION STANDARDS & DETAILS

REVISION/ISSUE DATE

6/2019

FORCE MAIN AIR RELEASE VALVE & VAULT  
OUTSIDE OF R/W, NON TRAFFIC AREAS

PAGE NO.

39S

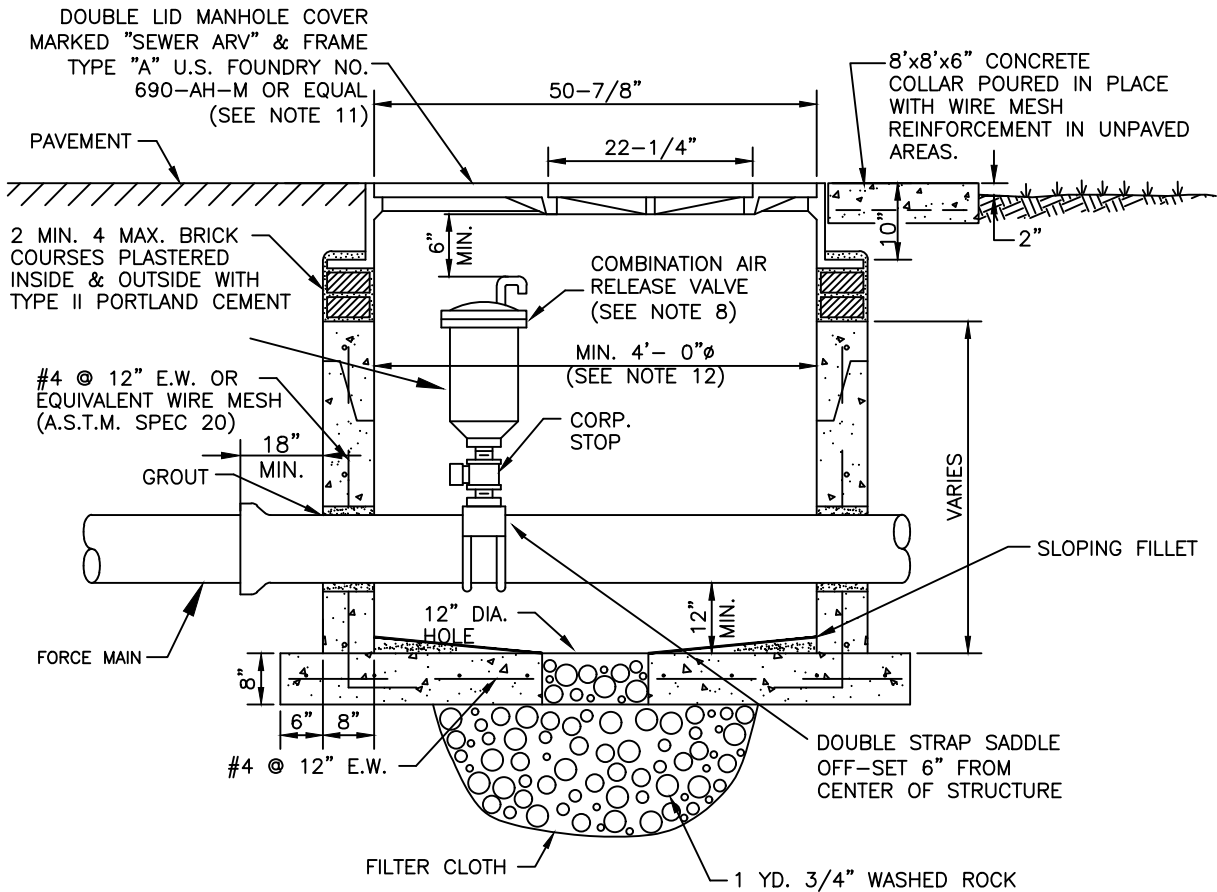

**NOTES:**

1. PRECAST 4000 P.S.I. TYPE II CONCRETE STRUCTURE. SHOP DRAWING IS REQUIRED TO BE APPROVED BY THE DEPARTMENT
2. ALL OPENINGS SHALL BE SEALED WITH A WATERPROOF NON-SHRINKING GROUT.
3. LIFT HOLES ARE PERMITTED.
4. ALL PIPE HOLES SHALL BE PRECAST.
5. MANHOLE FABRICATION SHALL BE IN ACCORDANCE WITH A.S.T.M. C-478 LATEST STANDARD.
6. COAT INSIDE WITH AN APPROVED PROTECTIVE CORROSION BARRIER SYSTEM.
7. CONCRETE COLLAR REQUIRED WHEN MANHOLE IS OUTSIDE OF PAVEMENT, SEE DETAIL.
8. COMBINATION AIR RELEASE VALVE (ARV) SHALL BE TYPE AND SIZE APPROPRIATE FOR SERVICE INTENDED. ALTHOUGH A 2" MINIMUM SIZED ARV IS REQUIRED ON FORCE MAIN INSTALLATIONS.
9. DUCTILE IRON PIPE IS REQUIRED THROUGH THE MANHOLE. NO PIPE JOINTS INSIDE THE MANHOLE.
10. THREADED AREAS OF CORPORATION STOP SHALL BE SPIRAL WRAPPED WITH TWO WRAPS OF TEFLON TAPE.
11. FORCE MAINS 12" AND SMALLER, AN ALTERNATIVE VAULT AND COVER DESIGN MAY BE USED PROVIDED ALTERNATE VAULT AND/OR COVER SHOP DRAWINGS WERE SUBMITTED AND APPROVED BY THE DEPARTMENT PRIOR TO THE VAULT AND/OR COVER BEING INSTALLED.
12. LARGER MANHOLES WILL BE REQUIRED FOR PIPES LARGER THAN 12"
 

PIPE SIZE	MIN. MANHOLE DIAMETER
16"-24"	60"
30"-42"	72"
13. MANHOLES IN ROADWAYS SHALL BE LOCATED OUTSIDE OF WHEEL PATHS.

PALM BEACH COUNTY CONSTRUCTION STANDARDS & DETAILS

REVISION/ISSUE DATE  
**6/2019**

**FORCE MAIN AIR RELEASE VALVE AND  
MANHOLE IN PAVED AREAS AND ROAD R/W**

PAGE NO.  
**40S**

**MIN. LENGTH OF PIPE (FEET) TO BE RESTRAINED**  
 (SOURCES: EBAA IRON RESTRAINT LENGTH CALCULATION PROGRAM FOR PVC PIPE, RELEASE 3.1, AND  
 DIPRA THRUST RESTRAINT FOR DUCTILE IRON PIPE, RELEASE 3.2)

FITTING TYPE	PIPE SIZE												
	4"	6"	8"	10"	12"	16"	20"	24"	30"	36"	42"	48"	
90° HORIZ. BEND	14	20	25	30	35	45	54	62	73	84	93	101	
45° HORIZ. BEND	6	8	11	13	15	19	22	26	30	35	38	42	
22.5° HORIZ. BEND	3	4	5	6	7	9	11	12	15	17	18	20	
11.25° HORIZ. BEND	1	2	3	3	4	4	5	6	7	8	9	10	
90° VERT. OFFSET	UPPER BEND	29	41	53	64	74	95	115	134	160	185	207	228
	LOWER BEND	7	10	13	16	19	25	30	35	42	49	56	62
45° VERT. OFFSET	UPPER BEND	12	19	24	29	34	39	48	56	66	77	86	94
	LOWER BEND	3	4	6	7	8	10	12	15	18	20	23	26
22.5° VERT. OFFSET	UPPER BEND	6	9	12	14	17	19	23	27	32	37	41	45
	LOWER BEND	1	2	4	4	4	5	6	7	8	10	11	12
11.25° VERT. OFFSET	UPPER BEND	3	4	6	7	8	9	11	13	16	18	20	22
	LOWER BEND	1	1	1	2	2	2	3	3	4	5	5	6
PLUG (DEAD END)	32	45	59	70	83	107	129	151	160	185	207	228	
IN-LINE VALVE	32	45	45	45	45	55	65	80	85	95	105	115	
TEE (BRANCH RESTRAINT)	4"X Ø	23	-	-	-	-	-	-	-	-	-	-	
	6"X Ø	21	35	-	-	-	-	-	-	-	-	-	
	8"X Ø	18	34	47	-	-	-	-	-	-	-	-	
	10"X Ø	16	32	46	58	-	-	-	-	-	-	-	
	12"X Ø	13	30	44	57	69	-	-	-	-	-	-	
	16"X Ø	7	26	41	55	67	90	-	-	-	-	-	
	20"X Ø	1	21	38	52	65	88	109	-	-	-	-	
	24"X Ø	1	16	34	49	62	86	108	129	-	-	-	
	30"X Ø	1	8	28	44	58	83	106	127	154	-	-	
	36"X Ø	1	1	22	39	54	80	103	124	153	179	-	
	42"X Ø	1	1	15	33	49	77	100	122	151	177	201	
48"X Ø	1	1	7	27	44	73	97	120	149	176	200	222	
REDUCER (LARGER PIPE RESTRAINT)	6"X Ø	23	-	-	-	-	-	-	-	-	-	-	
	8"X Ø	38	25	-	-	-	-	-	-	-	-	-	
	10"X Ø	57	43	24	-	-	-	-	-	-	-	-	
	12"X Ø	72	60	44	41	-	-	-	-	-	-	-	
	16"X Ø	99	90	78	75	45	-	-	-	-	-	-	
	20"X Ø	123	116	107	105	81	45	-	-	-	-	-	
	24"X Ø	146	140	132	131	111	82	45	-	-	-	-	
	30"X Ø	157	153	148	141	133	113	87	56	-	-	-	
	36"X Ø	182	179	175	169	163	147	126	101	56	-	-	
	42"X Ø	205	202	199	194	189	175	150	138	100	54	-	
48"X Ø	226	224	221	217	213	201	187	169	138	98	53		

**NOTES:**

- THE DATA IN THE ABOVE TABLE ARE BASED UPON THE FOLLOWING INSTALLATION CONDITIONS:  
 SOIL TYPE-SAND                      TEST PRESSURE-150 PSI                      DEPTH OF BURY-3'  
 TRENCH TYPE-3                      SAFETY FACTOR- 1.5                      VERTICAL OFFSET-3'  
 MINIMUM PIPE LENGTH ALONG TEE RUN-5'
- THE RESTRAINED PIPE LENGTHS APPLY TO DUCTILE IRON AND PVC PIPE.
- ALL JOINTS BETWEEN UPPER AND LOWER BENDS SHALL BE RESTRAINED.
- RESTRAINED PIPE LENGTHS APPLY TO PIPE ON BOTH SIDES OF VALVES AND FITTINGS.
- MULTIPLY PIPE LENGTH BY 1.4 FOR POLYETHYLENE ENCASED PIPE.
- RESTRAINED PIPE LENGTHS EQUAL TO AN "INLINE VALVE" CONDITION ARE REQUIRED AT EACH END OF A TRANSITION FROM HDPE PIPE TO OTHER PIPE MATERIALS.
- DESIGN ENGINEER IS RESPONSIBLE FOR PROPER RESTRAINT PIPE LENGTH SIZING FOR THE PROJECT.

PALM BEACH COUNTY CONSTRUCTION STANDARDS & DETAILS

REVISION/ISSUE DATE

6/2019

**MECHANICAL THRUST RESTRAINT  
 MINIMUM PIPE LENGTHS (FORCE MAINS)**

PAGE NO.

41S

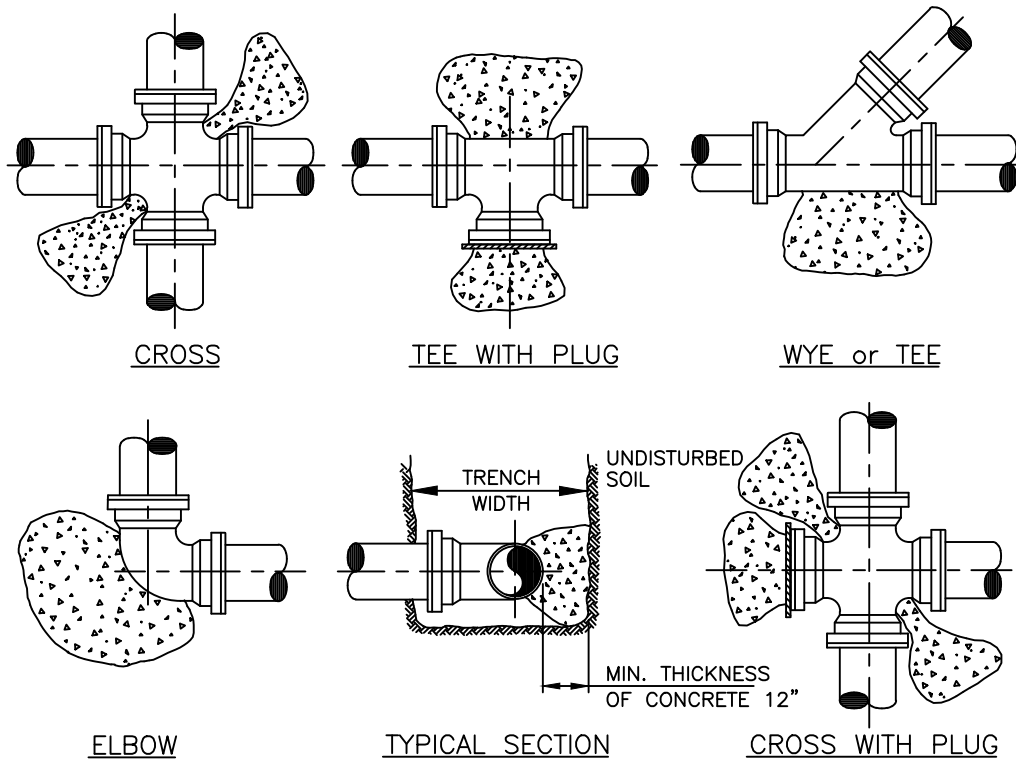

PIPE	THRUST BLOCK AREA REQ'D	REMARKS	NOTE: FOR OTHER FITTINGS USE THE FOLLOWING FACTORS.
4"	2.0 SQ. FT.	VALUES ARE FOR 90° BEND, BASED ON 2000 P.S.F. SAFE BEARING LOAD AND PIPE PRESSURE OF 150 P.S.I. FOR OTHER SOILS & PRESSURES THE AREA REQUIRED IS IN DIRECT PROPORTION	TEE 100% 45° BEND 71% 22 1/2' BEND 39% 11 1/4' BEND 20% DEAD END 100%
6"	4.0 SQ. FT.		
8"	6.6 SQ. FT.		
10"	10.0 SQ. FT.		
12"	14.0 SQ. FT.		
14"	18.6 SQ. FT.		

**NOTES:**

1. CONCRETE THRUST BLOCKS OR THRUST COLLARS MAY BE UTILIZED ONLY IF NECESSARY FOR CONNECTIONS TO AN EXISTING PIPING SYSTEM, OTHERWISE MECHANICAL RESTRAINTS SHALL BE USED. KEEP "1" BOLTS CLEAR OF CONCRETE, WRAPPED IN VISQUEEN FOR FUTURE ACCESS, WITH A MINIMUM OF 1' THICKNESS BETWEEN THE FITTING AND SOIL.
2. BEFORE POURING CONCRETE, PLUGS SHALL BE WRAPPED WITH VISQUEEN AND A BOARD PLACED IN FRONT.
3. CONCRETE SHALL BE 2500 P.S.I. MINIMUM.
4. THE ENGINEER OF RECORD SHALL SUBMIT A THRUST BLOCK SIZE CALCULATION FOR TEE CONNECTIONS INTO UNRESTRAINED EXISTING MAINS LARGER THAN 14".
5. THE ENGINEER OF RECORD SHALL SUBMIT A PIPE RESTRAINT DESIGN FOR INLINE EXTENSIONS OF A EXISTING UNRESTRAINED MAIN IF MECHANICAL JOINT RESTRAINT CAN NOT BE INSTALLED ON THE EXISTING MAIN.

PALM BEACH COUNTY CONSTRUCTION STANDARDS & DETAILS

REVISION/ISSUE DATE

6/2019

TYPICAL THRUST BLOCKS  
FOR PRESSURE PIPING

PAGE NO.

42S

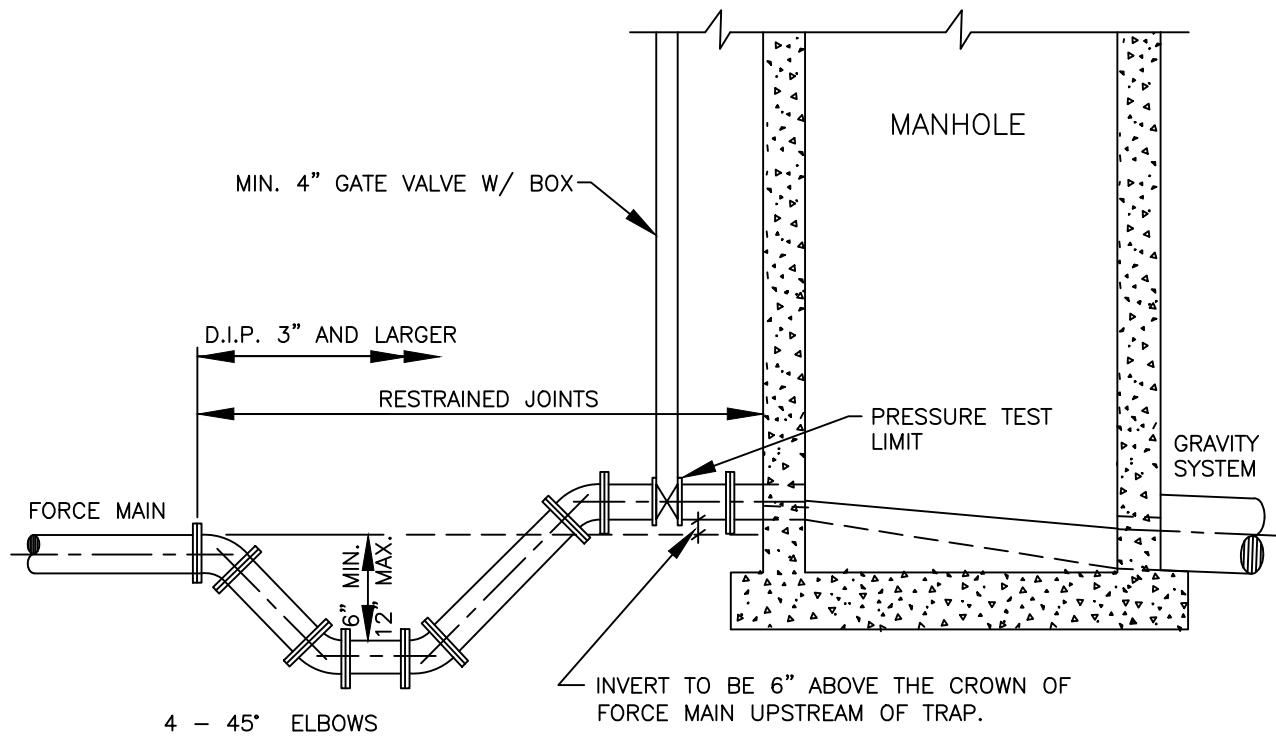

NOTES:

1. FORCE MAIN TO ENTER MANHOLE AS CLOSE AS POSSIBLE TO 180° TO GRAVITY OUTLET.
2. THE INVERT LEVEL OF FORCE MAIN AT POINT OF ENTRY SHALL BE 6" ABOVE OUTFLOW INVERT OF MANHOLE.
3. CORE ENTRY ONLY INTO EXISTING MANHOLES.
4. TRAP TO BE LOCATED PRIOR TO DROP INTO MANHOLE AND OUTSIDE OF PAVED AREAS.
5. USE TWO 45° ELBOWS PAST TRAP IF ELEVATION DROP IS REQUIRED TO ENTER MANHOLE.
6. CAST-IN OR FIELD INSTALLED FLOW CHANNEL IS REQUIRED.
7. MANHOLE WALL TO BE COATED WITH AN APPROVED SOLID THERMOPLASTIC CAST-IN CORROSION BARRIER SYSTEM.
8. TRAP JOINTS TO BE RESTRAINED.

PALM BEACH COUNTY CONSTRUCTION STANDARDS & DETAILS

REVISION/ISSUE DATE

6/2019

FORCE MAIN ENTERING MANHOLE

PAGE NO.

43S

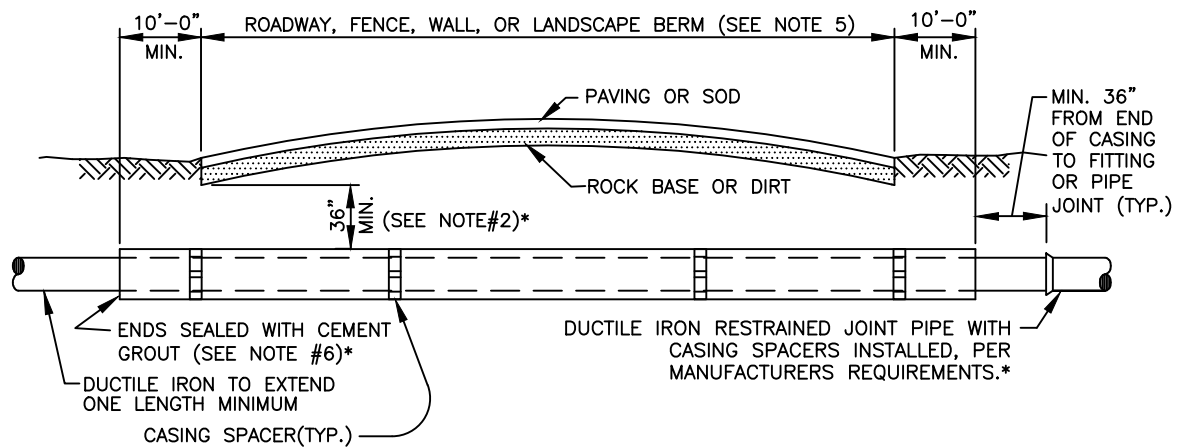

CARRIER PIPE SIZE	STEEL CASING INSIDE DIAMETER (MIN)	MINIMUM WALL THICKNESS (SEE NOTE 2)
4"	12"	.188
6"	14"	.250
8"	20"	.250
10"	20"	.250
12"	24"	.250
14"	24"	.250
16"	30"	.312
18"	30"	.312
20"	36"	.372
24"	42"	.500
30"	48"	.500
36"	54"	.625
42"	60"	.625
48"	72"	.625

**NOTES:\***

1. A PROFILE DRAWING TO SCALE FOR EACH JACK AND BORE, DIRECTIONAL DRILL, OR DIRECT BURIED INSTALLATION IS REQUIRED TO BE APPROVED BY THE DEPARTMENT PRIOR TO INSTALLATION. IF A SPLIT CASING IS REQUIRED SEE WUD DETAIL 44AW.\*
2. THE RIGHT-OF-WAY OWNER MAY REQUIRE THICKER WALL CASING AND LARGER COVER OVER CASING.\*
3. STEEL CASING SHALL BE COATED OUTSIDE WITH COAL TAR EPOXY (MIN. 16 MILS DFT) AND BE PAINTED WITH A 4" MINIMUM CONTINUOUS STRIPE, EUCLID GREEN IN COLOR, ALONG THE TOP SIDE OF THE CASING.\*
4. PIPE IN CASING SHALL BE PULLED TO FULLY ENGAGE RESTRAINT.
5. STEEL CASING IS REQUIRED FOR ALL POTABLE WATER MAIN INSTALLATIONS UTILIZING JACK AND BORE OR WHEN MAINS ARE INSTALLED UNDER FENCES, WALLS, OR LANDSCAPE BERMS. WHEN A CASING IS INSTALLED UNDER A FENCE, WALL, OR BERM SEE WUD STANDARD DETAIL 91S FOR INSTALLATION REQUIREMENTS.\*
6. NON-SHRINKABLE CEMENT GROUT TO BE INSTALLED TO OBTAIN WATERTIGHT SEAL AT EACH END OF CASING.\*

PALM BEACH COUNTY CONSTRUCTION STANDARDS & DETAILS

REVISION/ISSUE DATE

01/2023\*

WASTEWATER MAIN SOLID CASING  
INSTALLATION DETAIL\*

PAGE NO.

44SA\*



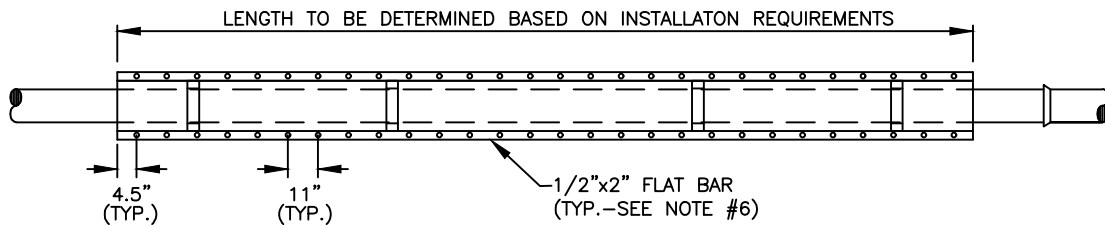

PLAN

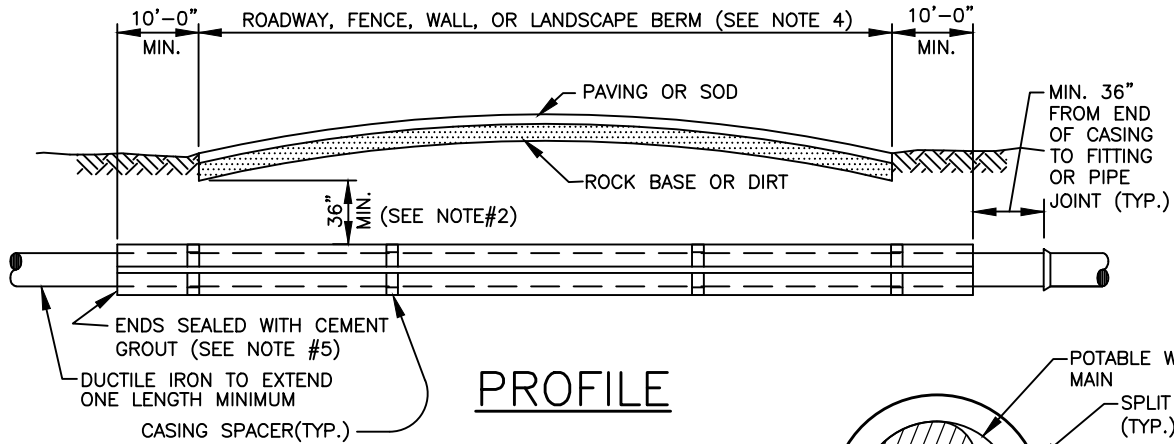

PROFILE

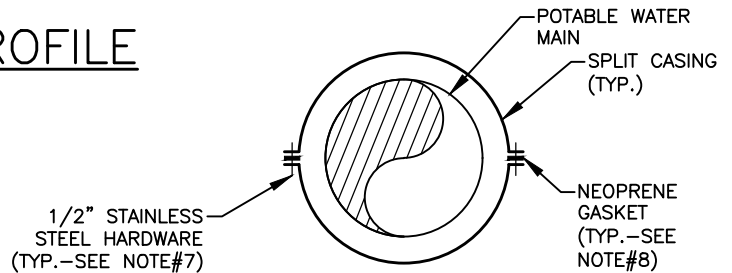

SECTION

CARRIER PIPE SIZE	STEEL CASING INSIDE DIAMETER (MIN)	MINIMUM WALL THICKNESS (SEE NOTE 2)
4"	12"	.188
6"	14"	.250
8"	20"	.250
10"	20"	.250
12"	24"	.250

NOTES:\*

1. A SHOP DRAWING TO SCALE FOR EACH SPLIT CASING INSTALLATION IS REQUIRED AND TO BE APPROVED BY THE DEPARTMENT PRIOR TO INSTALLATION.
2. THE RIGHT-OF-WAY OWNER MAY REQUIRE THICKER WALL CASING AND LARGER COVER OVER CASING.
3. STEEL CASING SHALL BE COATED OUTSIDE WITH COAL TAR EPOXY (MIN. 16 MILS DFT) AND BE PAINTED WITH A 4" MINIMUM CONTINUOUS STRIPE, ALASKA BLUE IN COLOR, ALONG THE TOP SIDE OF THE CASING.
4. SPLIT STEEL CASING IS REQUIRED ON ALL EXISTING WASTEWATER INSTALLATIONS WHEN A NEW STORM DRAINAGE OR OTHER UTILITY PIPE IS INSTALLED AND CANNOT ACHIEVE THE PROPER VERTICAL SEPARATION PER WUD STANDARDS ALONG WITH WHEN A NEW FENCE, WALL, OR LANDSCAPE BERM IS INSTALLED OVER AN EXISTING POTABLE WATER MAIN. WHEN A SPLIT CASING IS INSTALLED UNDER A FENCE, WALL, OR LANDSCAPE BERM SEE WUD STANDARD DETAIL 91S FOR INSTALLATION REQUIREMENTS.
5. NON-SHRINKABLE CEMENT GROUT TO BE INSTALLED TO OBTAIN WATERTIGHT SEAL AT EACH END OF CASING.\*
6. FLAT BARS TO BE STITCH WELDED AT 6" LENGTHS TO EDGE OF CASING ON EACH SIDE.
7. CASING TO BE ASSEMBLED IN FIELD WITH 1/2" STAINLESS STEEL BOLTS, WASHERS, AND NUTS ON EACH SIDE.
8. 1/4" NEOPRENE GASKET MATERIAL EXTENDING PAST CASING JOINT FOR POSITIVE SEAL ON EACH SIDE.

PALM BEACH COUNTY CONSTRUCTION STANDARDS & DETAILS

REVISION/ISSUE DATE

01/2023\*

WASTEWATER MAIN SPLIT CASING  
INSTALLATION DETAIL\*

PAGE NO.

44SB\*

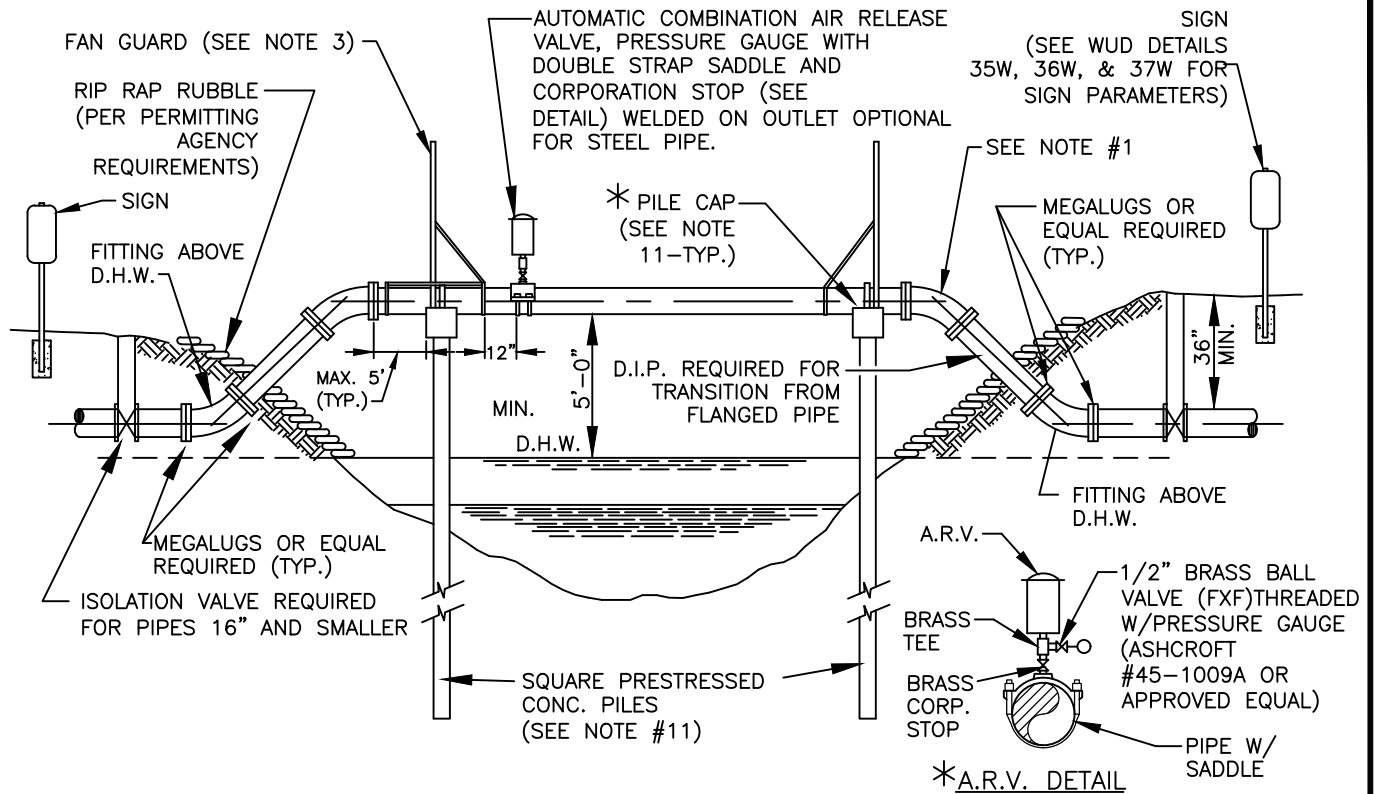

\*NOTES:

1. ALL EXPOSED PIPE SHALL BE DUCTILE IRON OR PREFABRICATED STEEL WITH FLANGED FITTINGS AND PROFILED GASKETS. RETAINER GLANDS AND UNIFLANGE TYPE FITTINGS ARE NOT TO BE SUBSTITUTED FOR FLANGED FITTINGS. PREFABRICATED STEEL PIPE MAY INCORPORATE WELDED ON LONG RADIUS UPPER BENDS. PREFABRICATED FLANGED PIPE SHALL BE FACTORY TESTED.
2. SPAN LENGTHS AS REQUIRED BY PERMITTING AGENCY
3. FAN GUARDS ARE REQUIRED. SEE FAN GUARD/PILE CAP DESIGN DETAIL 46S FOR ADDITIONAL REQUIREMENTS. ACCESS PLATFORM AND GATE REQUIRED ON ARV SIDE ONLY.
4. ALL STEEL PIPE SHALL HAVE WELDED ON BEARING PADS EXTENDED 1" MINIMUM BEYOND PIPE CRADLE WITH PAD INSTALLED PRIOR TO PAINTING. ALL EXPOSED STEEL PIPING SHALL BE PAINTED AS SPECIFIED IN THE APPROVED MATERIALS LIST WITH ALL HARDWARE BEING PAINTED WITH COAL-TAR EPOXY.
5. PIPE SHALL BE CRADLED ON 1/2" THICK NEOPRENE.(DUROMETER GRADE 50,) CURRENT FDOT STANDARDS APPLY. NEOPRENE IS REQUIRED AT ALL STRAPS INSTALLED OVER STEEL PIPE. NEOPRENE SHALL EXTEND MIN. 1" BEYOND THE EDGES OF CRADLE AND STRAPS.
6. TIE-DOWN STRAPS MUST PROPERLY FIT AND SECURE PIPE IN CRADLE.
7. PIPE CRADLE IN CAP SHALL CONTACT 1/3 CIRCUMFERENCE OF PIPE. (SEE FAN GUARD DETAIL 46S)
8. SHOW EXISTING CANAL CROSS SECTION ULTIMATE CANAL SECTION AND RELEVANT ELEVATIONS AND DISTANCES ON A TO SCALE DETAIL DRAWING.
9. PILE LIFT CABLE SHALL BE REMOVED BELOW SURFACE; HOLE SHALL BE FILLED WITH EPOXY CEMENT.
10. THREADED AREAS OF BRASS FITTINGS SHALL BE SPIRAL WRAPPED WITH TWO WRAPS OF TEFLON TAPE.
11. THE PILES AND CAP DESIGN TO BE ON DETAILED SHOP DRAWINGS. THE REQUIRED PILES SHALL BE 14"x14" MIN. - TYPE 1A PER FLORIDA DOT INDEX PILES. PILE PENETRATION BELOW CANAL BOTTOM SHALL BE 15' MINIMUM WITH EACH PILE LOAD CAPACITY BEING 20 TONS MINIMUM (FDOT STANDARDS APPLY). ALL REQUIRED AERIAL CROSSING SHOP DRAWINGS SHALL BE TO SCALE AND SIGNED AND SEALED BY A STRUCTURAL ENGINEER.
12. THE AERIAL CROSSING STRUCTURAL ENGINEER OF RECORD SHALL PROVIDE IN WRITING A SIGNED AND SEALED LETTER CERTIFYING THE AERIAL CROSSING INSTALLATION WAS COMPLETED PER HIS/HER DESIGN AND ALL APPLICABLE STANDARDS AND PERMITS.

PALM BEACH COUNTY CONSTRUCTION STANDARDS & DETAILS

REVISION/ISSUE DATE  
01/2023\*

TYPICAL FORCE MAIN AERIAL CANAL CROSSING -  
SINGLE PIPE (SINGLE PILES)

PAGE NO.  
45S

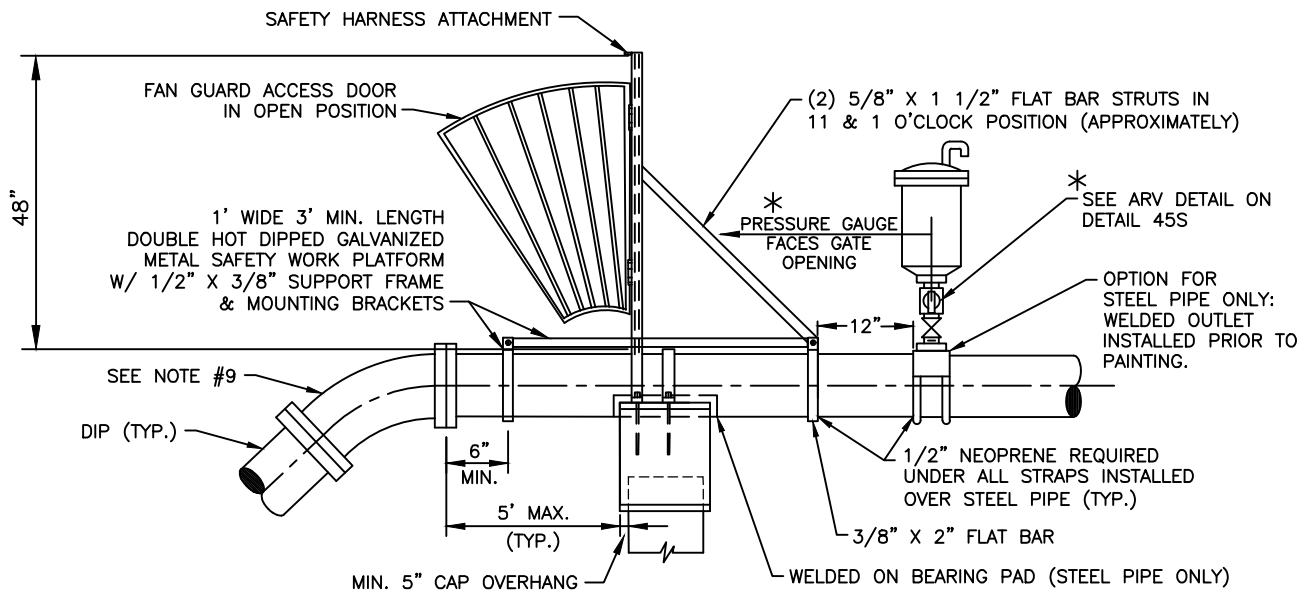
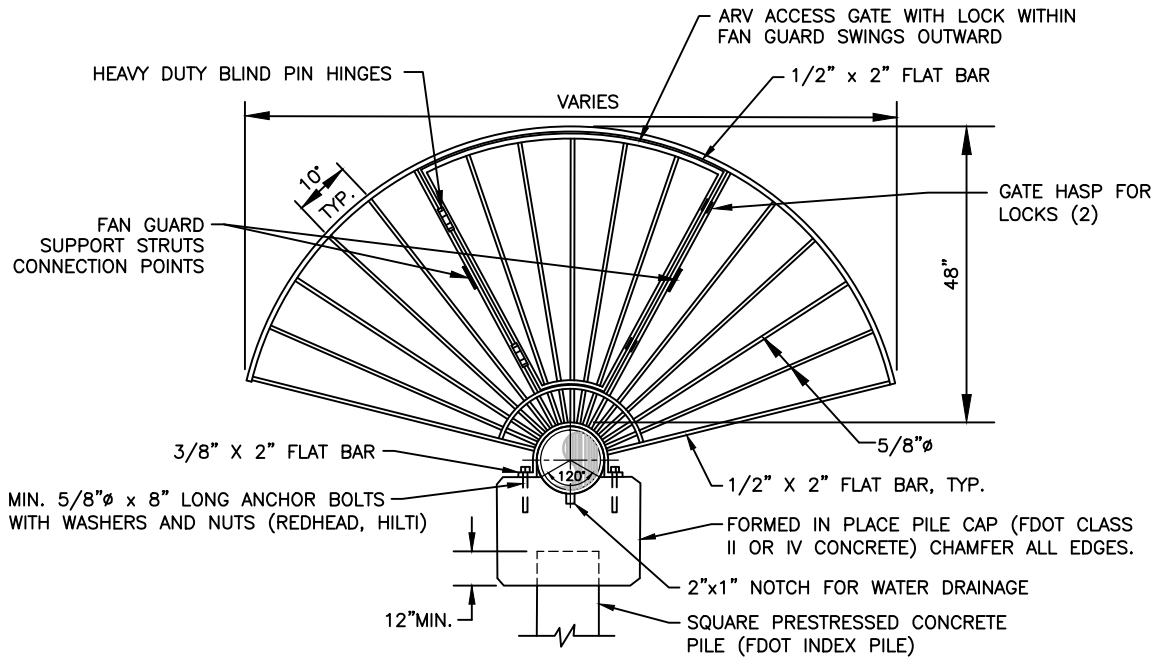

\*NOTES:

1. FAN GUARDS SHALL BE PLACED AT EACH END OF CANAL CROSSING.
2. FANGUARD WITH HARDWARE SHALL BE FABRICATED FROM DOUBLE HOT DIPPED GALVANIZED STEEL.
3. SHOP DRAWINGS FOR FANGUARDS, CAPS, AND PILES MUST BE SUBMITTED TO PBCWUD FOR REVIEW AND APPROVAL PRIOR TO PRE-CONSTRUCTION MEETING.
4. REINFORCING STEEL SHALL CONFORM TO ASTM A-615, GRADE 60. MIN. 2" CONCRETE COVER OVER ALL STEEL.
5. NO WELDING OF REBAR TO REBAR OR REBAR TO PILE STRANDS SHALL BE ALLOWED.
6. LONG RADIUS WELDED ON UPPER BENDS ARE ACCEPTABLE FOR STEEL PIPE.
7. THE PILE/CAP STEEL CONNECTION SHALL BE WITH A MINIMUM OF 4-#8 REINFORCEMENT BARS. THE BARS SHALL BE DRILLED AND DOWLED (EPOXIED) A MINIMUM OF 14" IN DEPTH INTO THE PILE AND TIED TO THE CAP STEEL.
8. ACCESS PLATFORM AND GATE REQUIRED ON ARV SIDE ONLY.
9. SEE TYPICAL AERIAL CROSSING DETAIL 45S FOR ADDITIONAL REQUIREMENTS.

PALM BEACH COUNTY CONSTRUCTION STANDARDS & DETAILS

REVISION/ISSUE DATE

01/2023\*

FAN GUARD/PILE CAP DESIGN –  
SINGLE PIPE (SINGLE PILES)

PAGE NO.

46S

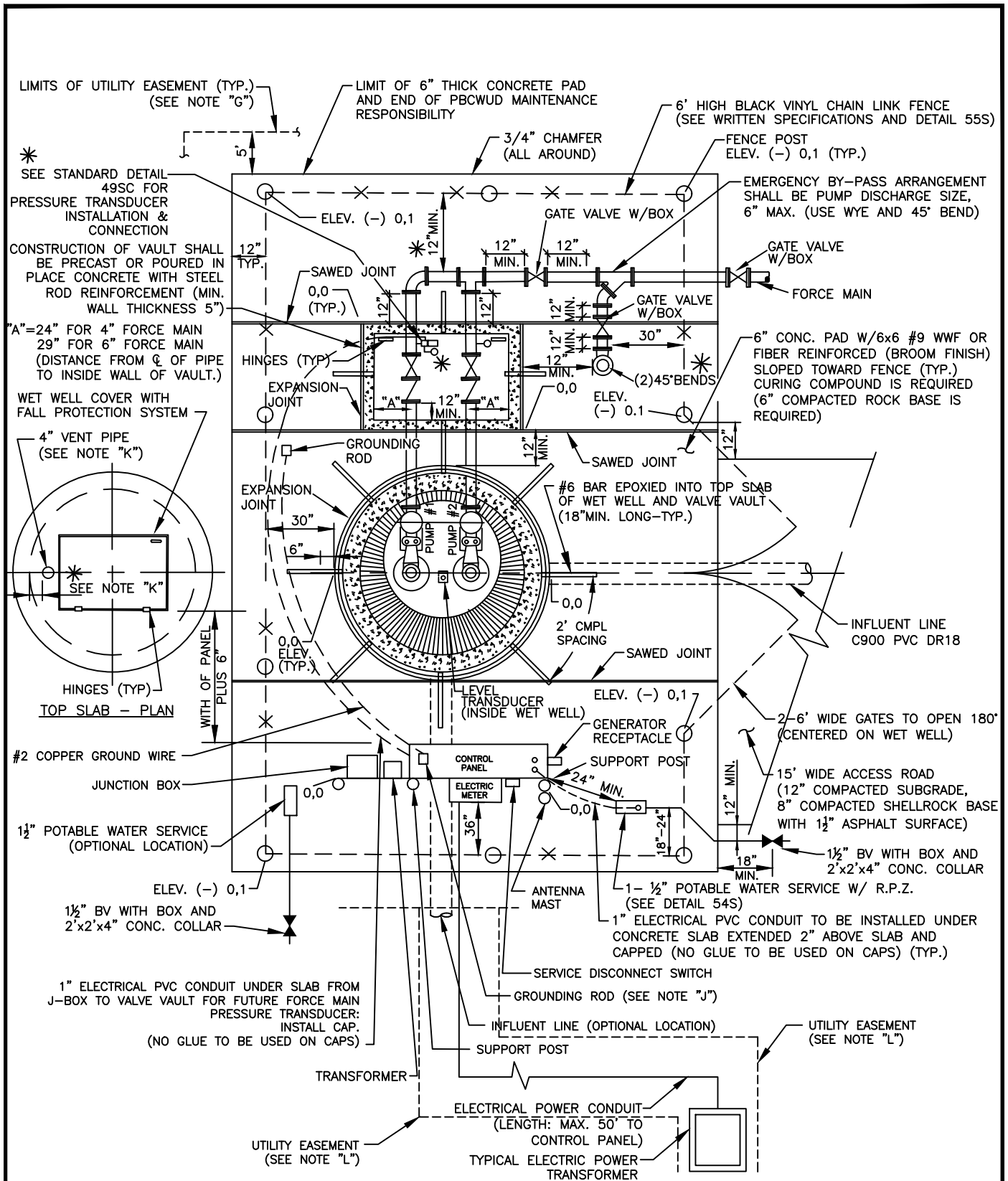

NOTE: SEE DETAIL 48S FOR NOTES RELATED TO 47S

PALM BEACH COUNTY CONSTRUCTION STANDARDS & DETAILS

REVISION/ISSUE DATE  
01/2023\*

TYPICAL LIFT STATION  
SITE PLAN DETAIL

PAGE NO.  
47S

NOTES:

- A. ENGINEER SHALL DESIGN SITE PLAN USING THE "TYPICAL LIFT STATION SITE PLAN DETAIL".  
"SITE PLAN LOCATION" DETAIL SHALL BE DRAWN TO SCALE NOT SMALLER THAN 1"=10' WITH:
1. NORTH ARROW, STREET NAME.
  2. FENCE WITH 2-6' WIDE GATES.
  3. INFLUENT LINE ENTRY LOCATION WITH MANHOLE AND GRAVITY MAIN DATA.
  4. HINGE LOCATION (HINGES FOR WET WELL COVER MUST BE LOCATED ON THE CONTROL PANEL SIDE; HINGED FOR VALVE VAULT COVER SHALL BE LOCATED ON DISCHARGE SIDE OF FORCE MAIN.)
  5. POWER SERVICE FEED (WITH "AS BUILTS"). MAXIMUM LENGTH OF ELECTRICAL SERVICE FROM THE TRANSFORMER / HANDHOLE TO CONTROL PANEL SHALL BE 50 FEET.
  6. EMERGENCY PUMP OUT LOCATION (SHALL BE SAME SIZE AS PUMP DISCHARGE).
  7. THE STATION SHALL BE POSITIONED SO THE FRONT OF CONTROL PANEL DOES NOT FACE WEST OR SOUTH (NORTH AND EAST ARE PREFERRED)
- B. HORIZONTAL DISTANCE FROM PANEL FRONT TO WET WELL OPENING.  
SHALL BE: WIDTH OF CONTROL PANEL PLUS 6".
- C. DESIGN TO BE COORDINATED WITH "TYPICAL LIFT STATION PLAN DETAIL".
- D. FENCED AREA TO BE COVERED WITH 2 PLY 4.0 (FOUR) MIL VISQUEEN AND A 6" CONCRETE PAD WITH #9 WIRE MESH (6" x 6") - BROOM FINISH REQUIRED.  
CONCRETE PAD TO EXTEND 12" BEYOND FENCED AREA.
- E. INFLUENT MAIN SHALL BE CLEAR OF VAULT.
- F. LANDSCAPE AREA ADJACENT TO LIFT STATION SITE MAY BE SUBJECT TO PRIOR \* APPROVAL BY THIS DEPARTMENT. ONLY HEDGES WITH NON-AGGRESSIVE ROOT SYSTEM WILL BE APPROVED. HEDGES ARE REQUIRED TO BE FIVE (5) FEET MINIMUM FROM THE EDGE OF THE CONCRETE PAD AND/OR DRIVEWAY. TREES ARE REQUIRED TO BE TEN (10) FEET MINIMUM FROM THE DRIVEWAY ONLY WITH PRIOR APPROVAL BY THIS DEPARTMENT. THE DEVELOPER AND SUCCESSOR SHALL BE RESPONSIBLE FOR ALL LANDSCAPE MAINTENANCE INCLUDING ALL SODDED AREAS. APPROVED HEDGES ARE: EUGENIA, SURINAM CHERRY, WAX MYRTLE, SIMPSON STOPPER, AND SOUTHERN RED CEDAR. NO WOODEN FENCES ARE PERMITTED WITHIN THE LIFT STATION EASEMENT AREA GRANTED BY PLAT OR BY SEPERATE INSTRUMENT.
- G. A PLATTED LIFT STATION EASEMENT OR EXCLUSIVE PALM BEACH COUNTY UTILITY EASEMENT (PBCUE) BY SEPERATE INSTRUMENT IS REQUIRED TO EXTEND FIVE (5) FEET MINIMUM PAST THE LIFT STATION CONCRETE PAD.
- H. ALL EXPOSED (NOT BURIED) JOINTS SHALL BE FLANGED, BURIED JOINTS SHALL BE MECHANICAL JOINT TYPE WITH MEGALUGS OR EQUAL.
- I. VALVE VAULT DIMENSIONS (INSIDE):
1. 4" PIPING: 4'(L) X 6'(W) X 4'(D)
  2. 6" PIPING: 5'(L) X 7'(W) X 4'(D)
- J. MINIMUM TWO GROUNDING RODS SHALL BE MIN. 6' APART AND SHALL BE RECESSED THROUGH 6" PVC SLEEVES IN CONCRETE SLAB. THE RODS SHALL BE CONNECTED WITH A #2 BARE TINNED COPPER GROUNDING WIRE.
- K. WETWELL VENT PIPE SHALL BE INSTALLED SO NOT TO INTERFERE WITH ACCESS TO THE WETWELL AND INSTALLED OPPOSITE OF GATE.
- L. THE ELECTRIC POWER SERVICE FEED FROM THE POWER TRANSFORMER TO THE CONTROL PANEL SHALL BE LOCATED WITHIN AN UTILITY EASEMENT.

PALM BEACH COUNTY CONSTRUCTION STANDARDS & DETAILS

REVISION/ISSUE DATE

01/2023\*

TYPICAL  
LIFT STATION SITE PLAN NOTES

PAGE NO.

48S

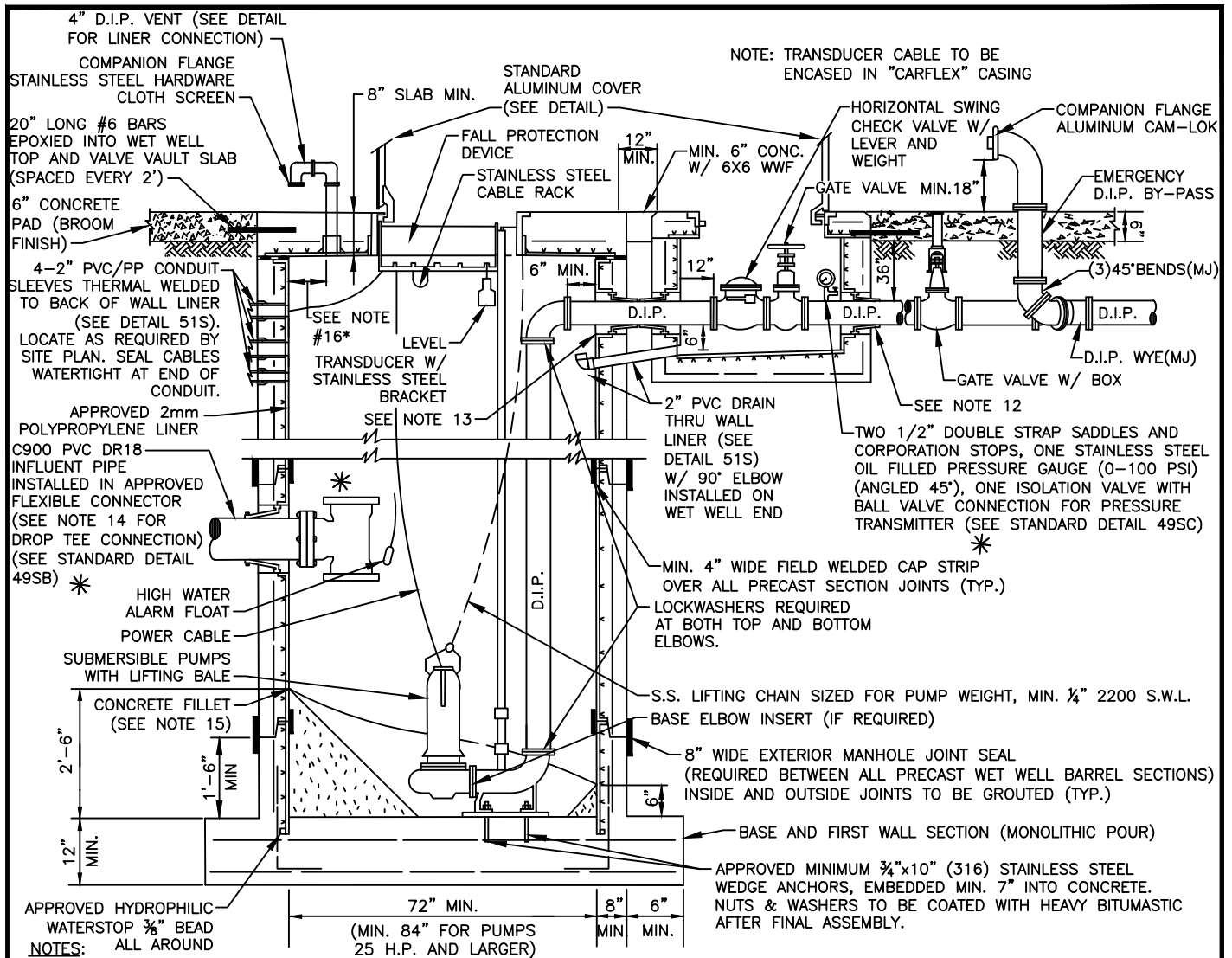

- APPROVED HYDROPHILIC WATERSTOP  $\frac{3}{8}$ " BEAD ALL AROUND
- INSTALL APPROVED GASKET MATERIAL AT ALL SECTION JOINTS PER GASKET MANUFACTURER'S SPECIFICATIONS. SHOP DRAWINGS TO IDENTIFY THE SIZE AND PLACEMENT OF JOINT SEALANT. JOINT PRIMER SHALL BE APPLIED BY THE PRECASTER.
  - PIPING IN WET WELL AND VALVE VAULT TO RECEIVE 2 COATS OF KOPPERS BITUMASTIC 300M, 8-10 MILS EA. COAT, OR APPROVED EQUAL.
  - ALL STEEL IN WET WELL SHALL BE STAINLESS STEEL, INCLUDING GUIDE BARS, LIFTING CHAIN, CABLE SUPPORTS, CABLE HOLDER, AND GUIDE BAR BRACKET (TYPE 316).
  - TYPE II REINFORCED CONCRETE (#4 BARS THROUGHOUT), 4000 P.S.I. CALCAREOUS AGGREGATE REQUIRED (MIN. CaCO<sub>3</sub> CONTENT: 65% IN LARGE AGGREGATE, 50% IN CONCRETE SCREENING).
  - SEE PLAN FOR CORRECT ORIENTATION OF PIPES, VENT, AND OTHER FIXTURES.
  - ALL HARDWARE INSIDE AND OUTSIDE OF WET WELL AND VALVE PIT SHALL BE STAINLESS STEEL (TYPE 316).
  - A. INSTALL  $\frac{3}{8}$ " THICK STAINLESS STEEL PLATE THAT EXTENDS MIN. 3" AROUND PERIMETER OF BASE ELBOW.  
B. BASE ELBOW ANCHORS SHALL BE MIN.  $\frac{3}{4}$ "x10" (316) S.S., DOUBLE NUTTED, MIN. 2" THREAD LENGTH, TORQUED TO 150 FOOT POUNDS.
  - THREADED AREAS OF CORPORATION STOP SHALL BE SPIRAL WRAPPED WITH TWO WRAPS OF TEFLON TAPE.
  - INTERIOR OF A NEW WET WELL SHALL BE LINED WITH ANY APPROVED SOLID CAST-IN LINER SYSTEM. LINERS MAY ONLY BE WELDED BY WELDERS CERTIFIED BY THE LINER MANUFACTURER AND CAST INTO THE STRUCTURE BY A PRECASTER CERTIFIED BY THE LINER MANUFACTURER. VALVE VAULT MAY BE LINED WITH ANY APPROVED CORROSION BARRIER SYSTEM.
  - WALL THICKNESS AND REINFORCING ARE PER ASTM C-478 LATEST REVISION.
  - ALL DRAIN LINES, CONDUITS, AND VENT PIPES WILL BE CONNECTED TO THE CAST-IN LINER PER THE MFG'S. SPECIFICATIONS (SEE DETAILS). ALL PIPE CONNECTIONS SHALL BE GAS TIGHT AND WATERTIGHT WITH NO EXPOSED CONCRETE SURFACES.
  - CAST OPENINGS SHALL BE MANUFACTURED WITH A CAST-IN POLYPROPYLENE SLEEVE. APPROVED FLEXIBLE CONNECTORS SHALL BE USED AT INFLUENT AND DISCHARGE PIPE CONNECTIONS. HOLE SIZE BY BOOT MFG'S. SPECIFICATIONS. DOUBLE PIPE CLAMPS MUST BE INSTALLED ON FLEXIBLE CONNECTORS WHERE REQUIRED BY BOOT MFG'S. INSTALLATION INSTRUCTIONS (SEE DETAIL).
  - CORED PIPE OPENINGS SHALL BE INSTALLED PER DETAIL. APPROVED FLEXIBLE CONNECTORS WILL BE INSTALLED ONTO POLYPROPYLENE WALL SLEEVE. WALL SLEEVE SHALL BE EPOXIED INTO CORED OPENING AND THERMAL WELDED TO WALL LINER (SEE DETAIL). WELDING SHALL BE PERFORMED EXCLUSIVELY BY LICENSED CERTIFIED WELDERS.
  - ALL BOLT PENETRATIONS THROUGH LINER SHALL BE SEALED WITH AN APPROVED HYDROPHILIC RUBBER CAULKING AND PLACED SO THAT A COMPRESSION SEAL WILL DEVELOP IN THE PRESENCE OF MOISTURE (SEE DETAIL).
  - SEAL LINER/FILLET INTERFACE WITH 3M WEATHERBAN 5354 SEALANT TAPE OR AN APPROVED EQUAL.
  - VENT PIPE TO BE LOCATED 3 INCHES ON 6 FOOT DIAMETER WET WELL AND 4 INCHES ON 8 FOOT DIAMETER WET WELL FROM THE INTERIOR WET WELL WALL.\*

PALM BEACH COUNTY CONSTRUCTION STANDARDS & DETAILS

REVISION/ISSUE DATE  
01/2023\*

TYPICAL LIFT STATION SECTION WITH  
CAST-IN LINER

PAGE NO.  
49SA\*

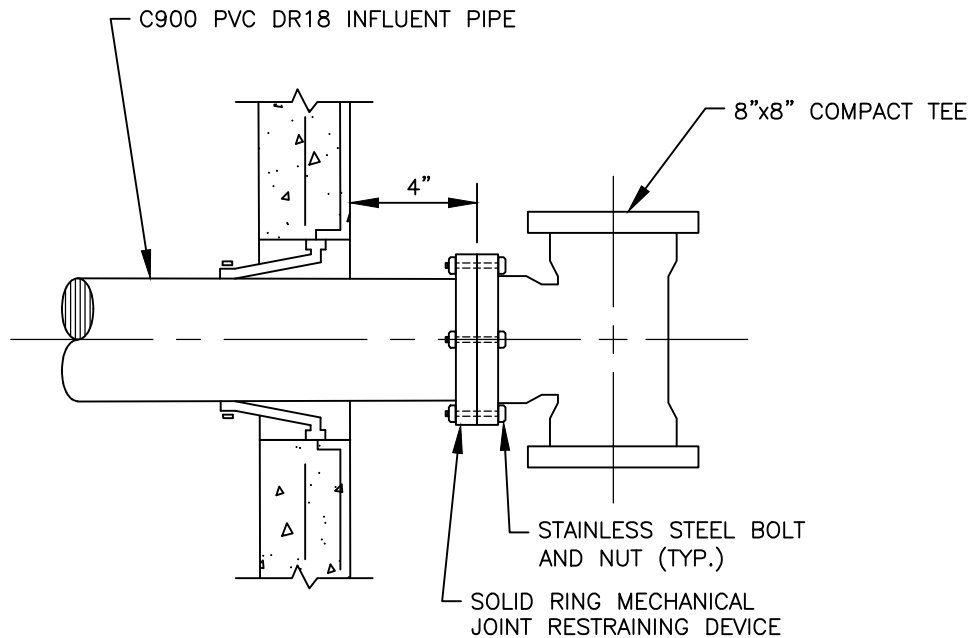

NOTES:

1. C900 INFLUENT PIPE TO EXTEND INTO WET WELL TO CONNECT TO A MECHANICAL JOINT DUCTILE IRON COMPACT 8"x8" TEE.
2. BRANCH END OF COMPACT 8"x8" TEE TO BE INSTALLED FOUR (4) INCHES FROM THE WET WELL INTERIOR WALL.
3. CONNECT INFLUENT PIPE TO COMPACT TEE USING SOLID RING MECHANICAL JOINT RESTRAINING DEVICE FOR PVC PIPE.
4. ALL HARDWARE (BOLTS,NUTS,ETC.) TO BE STAINLESS STEEL TYPE 316.

PALM BEACH COUNTY CONSTRUCTION STANDARDS & DETAILS

REVISION/ISSUE DATE  
01/2023\*

TYPICAL LIFT STATION SECTION DROP PIPE  
DETAIL & NOTES\*

PAGE NO.  
49SB\*

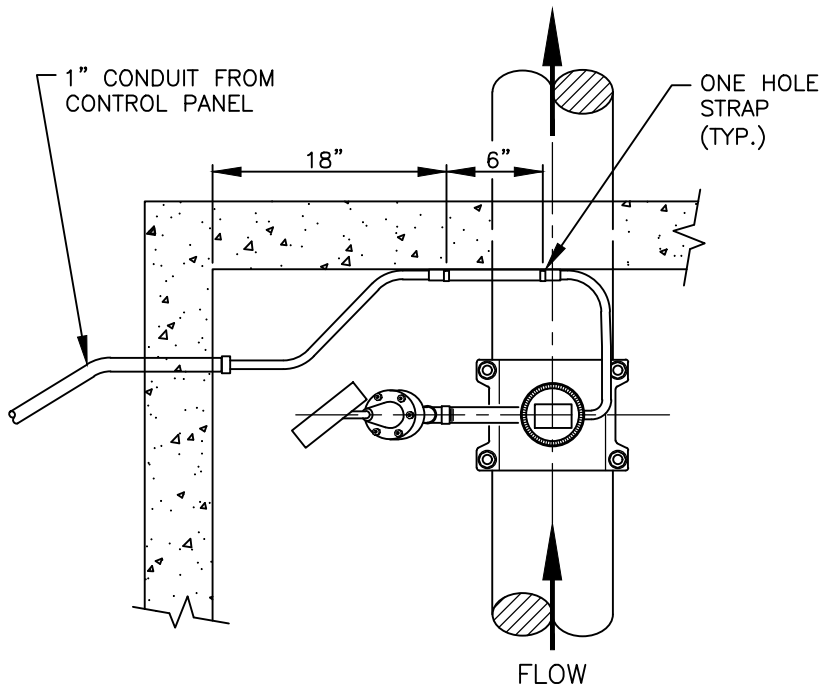

PLAN

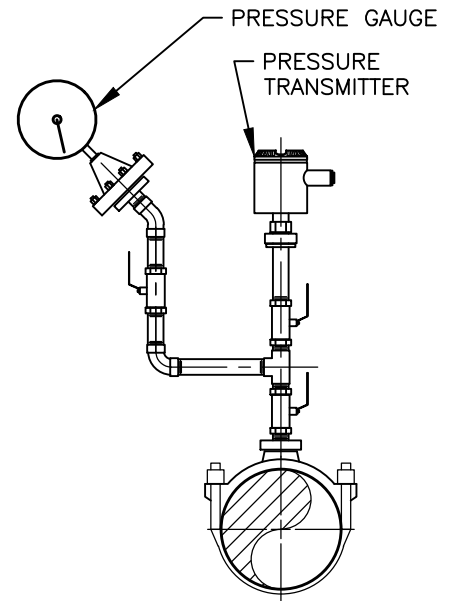

PROFILE

NOTES:

1. CONNECT A 3/4" FLEX CONDUIT FROM THE PRESSURE TRANSMITTER TO THE 1" CONDUIT FROM LIFT STATION CONTROL PANEL CONDUIT TO BE ANCHORED TO VALVE VAULT WALL WITH TWO ONE-HOLE STAINLESS STEEL STRAPS AND 1/4" STAINLESS STEEL SCREW ANCHORS.
2. A 9" LONG, 3/4" RIDGID CONDUIT TO BE ANCHORED TO VALVE VAULT WALL WITH TWO (2) ONE HOLE STAINLESS STEEL STRAPS AND A 1/4" STAINLESS STEEL SCREW ANCHOR IN EACH STRAP.
3. CONNECT A 3/4" FLEX CONDUIT FROM THE PRESSURE TRANSMITTER TO THE 3/4" RIDGID CONDUIT ON THE WALL. THEN CONNECT A 3/4" FLEX CONDUIT FROM THE 1" CONDUIT FROM THE LIFT STATION PANEL TO THE 3/4" RIDGID CONDUIT ON THE WALL.
4. THE PRESSURE GAUGE MUST BE INSTALLED ON AN ANGLE SO IT CAN BE READ FROM OUTSIDE THE VALVE VAULT.

PALM BEACH COUNTY CONSTRUCTION STANDARDS & DETAILS

REVISION/ISSUE DATE  
01/2023\*

TYPICAL LIFT STATION VALVE VAULT  
PRESSURE TRANSMITTER  
DETAIL & NOTES\*

PAGE NO.  
49SC\*



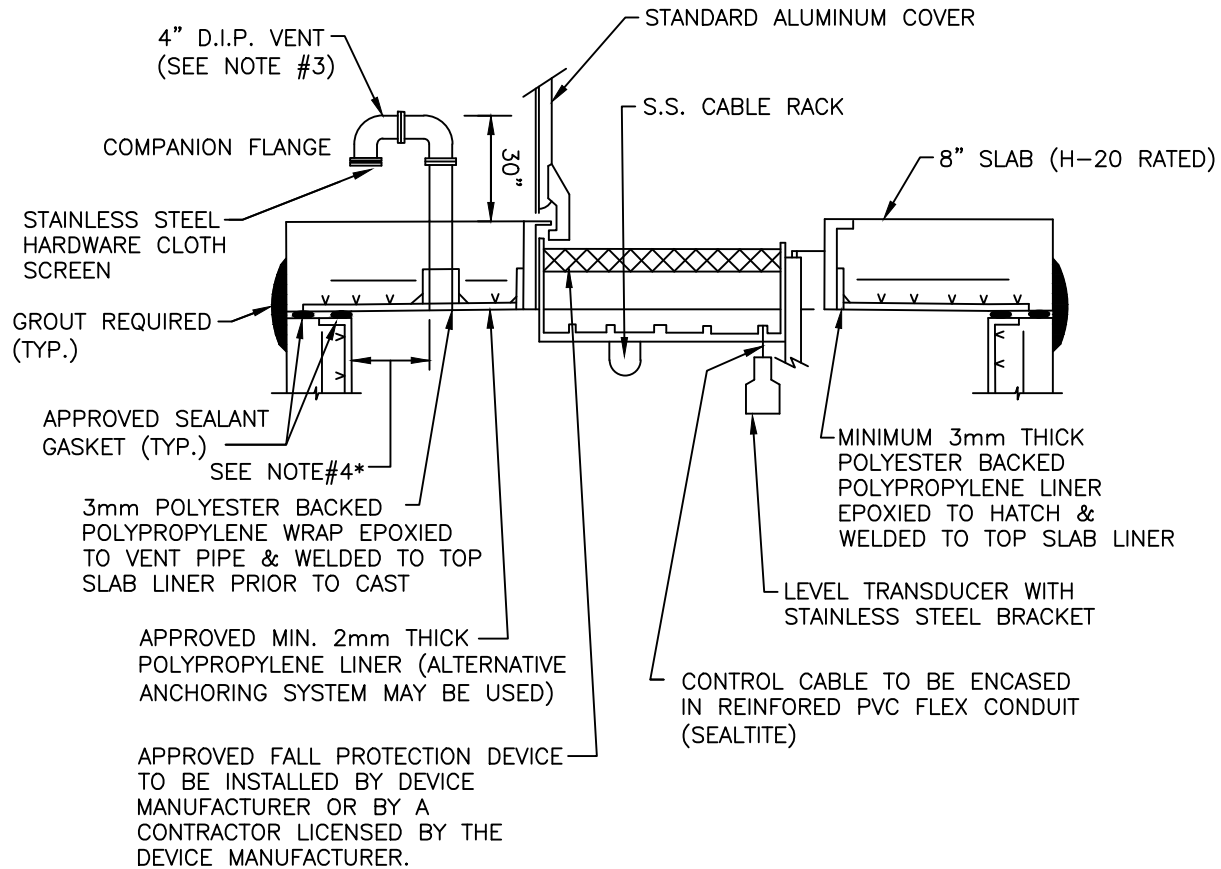

NOTES:

1. A FIELD WELDED CAP STRIP OVER THE WETWELL/TOP SLAB JOINT IS NOT REQUIRED.
2. THE LEVEL TRANSDUCER SHALL BE LOCATED NEAR THE CORNER OF THE ACCESS OPENING, OPPOSITE OF PUMP GUIDE RAILS AND OPPOSITE OF SEWER INFLOW INVERT. THE CONTROL WIRE SHALL BE ENCASED IN 3/4" CONDUIT SEALTITE.
3. THE WETWELL VENT SHALL BE LOCATED OPPOSITE OF THE ACCESS GATE.
4. VENT PIPE TO BE LOCATED 3 INCHES ON A 6 FOOT DIAMETER WET WELL AND 6 INCHES ON A 8 FOOT DIAMETER WET WELL FROM THE INTERIOR WET WELL WALL.\*

PALM BEACH COUNTY CONSTRUCTION STANDARDS & DETAILS

REVISION/ISSUE DATE

01/2023\*

LIFT STATION TOP SLAB\*

PAGE NO.

50S

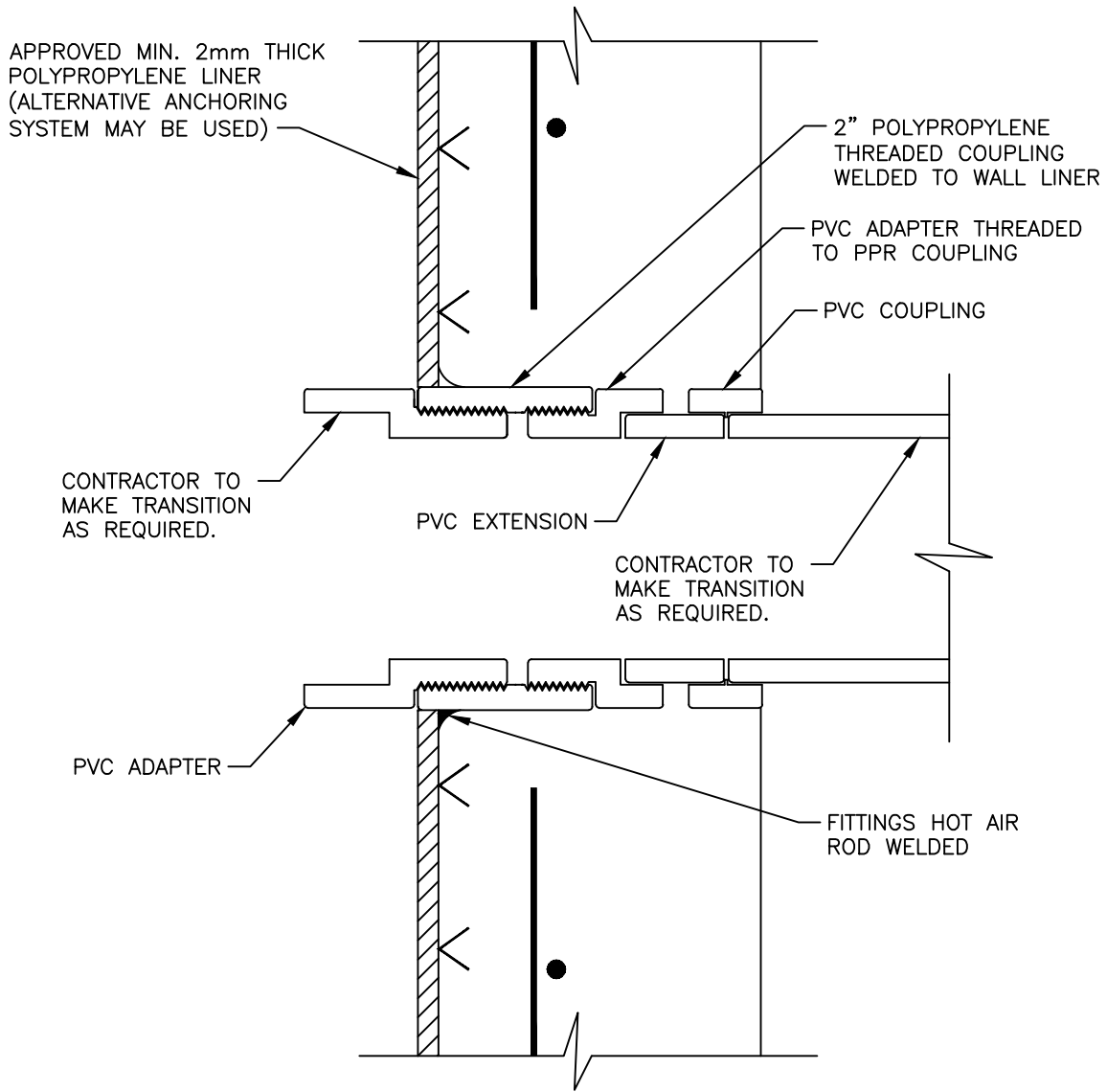

LINER TREATMENT FOR MISC. SMALL PIPE CONNECTIONS

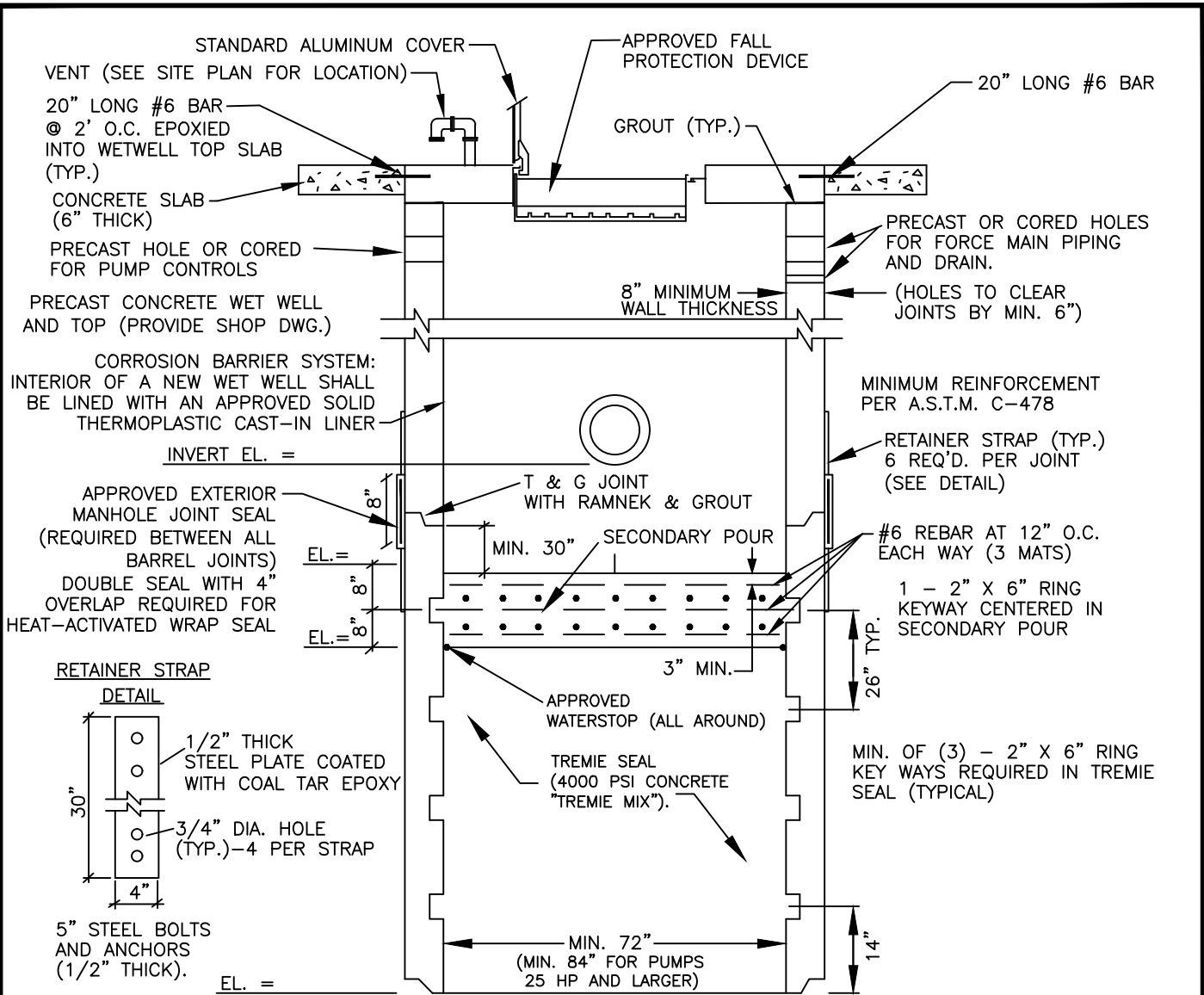

**NOTES:**

1. CONCRETE USED FOR TREMIE SEAL AND SECONDARY POUR MUST BE 4000 P.S.I. AT 28 DAYS WITH TYPE II PORTLAND CEMENT.
2. MIN. OF FOUR 2" X 6" RING KEYWAYS REQUIRED WITH TOP KEYWAY CENTERED IN THE SECONDARY CONCRETE POUR.
3. TREMIE SEAL REQUIRED TO BE A MINIMUM OF 84" THICK AND SECONDARY CONCRETE POUR MIN. 16" THICK.
4. TREMIE SEAL TO CURE MINIMUM 72 HOURS PRIOR TO PUMPING OFF WATER TO PREPARE FOR SECONDARY CONCRETE POUR.
5. ENGINEER OF RECORD SHALL SUBMIT SIGNED AND SEALED BUOYANCY CALCULATIONS TO PBCWUD FOR REVIEW AND APPROVAL. FLOATATION CALCULATION SHALL BE BASED ON 25 YR. FLOOD STAGE DURING CONSTRUCTION AND ON 100 YR. FLOOD STAGE WITH SECONDARY POUR INCLUDED.
6. WEIGHT OF TOP SLAB, SECONDARY CONCRETE POUR, PUMPS AND EXTERIOR SKIN FRICTION SHALL NOT BE INCLUDED IN BUOYANCY CALCULATIONS. GROUNDWATER SHALL BE CONSIDERED AT GROUND LEVEL FOR BUOYANCY CALCULATIONS.
7. SEE TYPICAL LIFT STATION DETAILS FOR ADDITIONAL DESIGN AND CONSTRUCTION STANDARDS.
8. WET WELL RISERS SHALL BE MIN. 24", MAX. 72" TALL. CALCAREOUS AGGREGATE REQUIRED (MIN. CaCO3 CONTENT: 65% IN LARGE AGGREGATE, 50% IN CONCRETE SCREENING).
9. CONCRETE BARREL SECTIONS SHALL BE INSTALLED BY CLAMSHELL/CRANE METHOD. DAMAGED SECTIONS WILL NOT BE ACCEPTED.
10. NO CONCRETE SHALL BE PLACED UNLESS WATER LEVEL IN WET WELL IS EQUAL TO OUTSIDE WATER TABLE ELEVATION. INSIDE WATER LEVEL SHALL BE MAINTAINED AT WATER TABLE ELEVATION AT ALL TIMES DURING CONCRETE PLACEMENT.
11. THE CONCRETE TREMIE SEAL RAISE RATE SHOULD BE MAINTAINED BY CONTRACTOR TO ASSURE NO COLD JOINT OCCURS IN SEAL.
12. MIN. PUMP SIZE TO BE 2" MAXIMUM CHUTE SIZE TO BE 12".
13. ENGINEER OF RECORD OR HIS REPRESENTATIVE SHALL BE PRESENT DURING THE WET WELL SETTING AND TREMIE POUR PROCEDURE. ANY CORRECTIVE ACTION FOR LOST SEAL OCCURRENCE SHALL BE DOCUMENTED AND APPROVED BY THE ENGINEER OF RECORD.
14. DROP PIPE IS REQUIRED ON ALL LIFT STATIONS, SEE DETAIL 49SB.\*

PALM BEACH COUNTY CONSTRUCTION STANDARDS & DETAILS

REVISION/ISSUE DATE

01/2023\*

LIFT STATION WETWELL SETTING  
TREMIE POUR DETAIL\*

PAGE NO.

52S

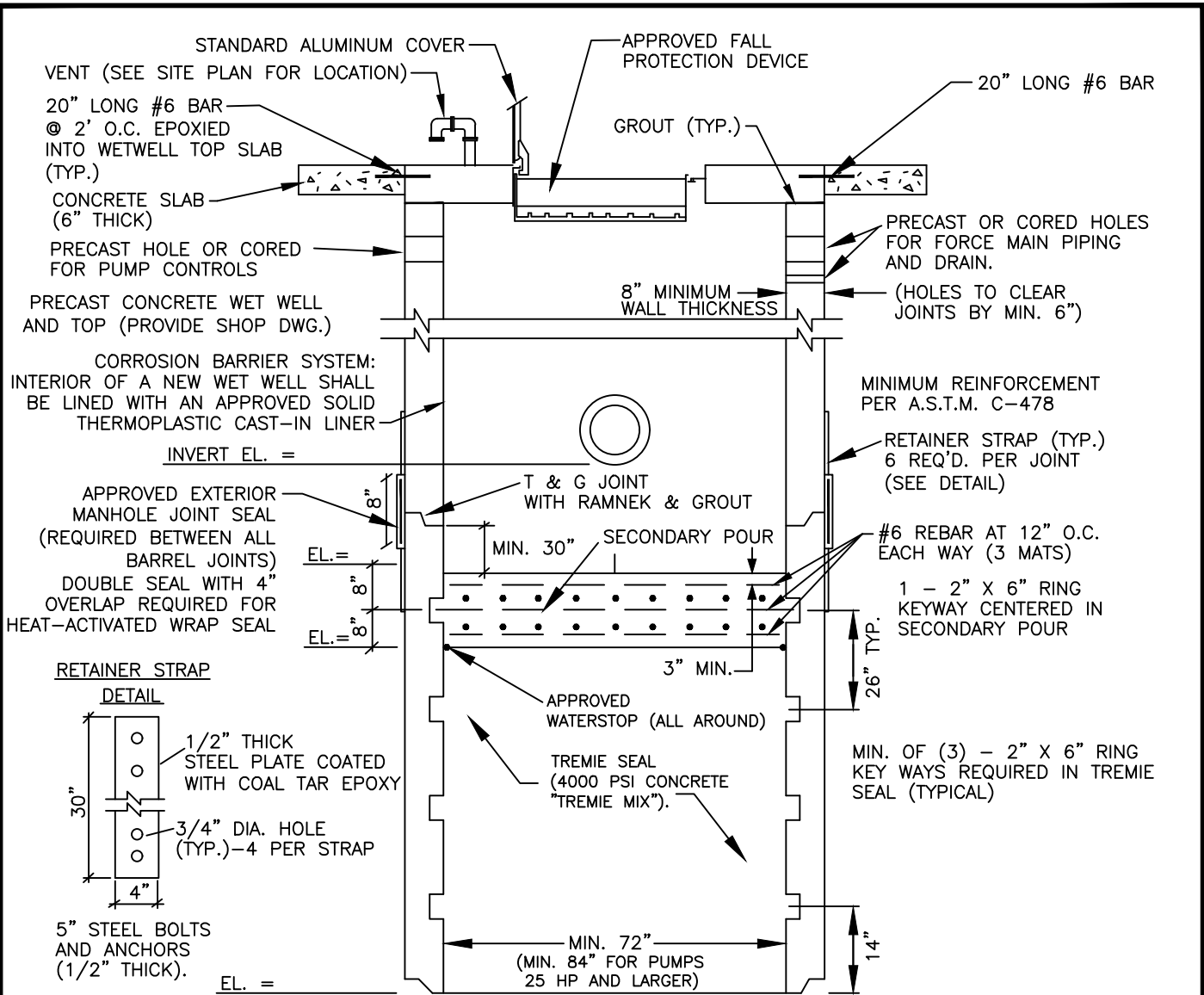

**NOTES:**

1. CONCRETE USED FOR TREMIE SEAL AND SECONDARY POUR MUST BE 4000 P.S.I. AT 28 DAYS WITH TYPE II PORTLAND CEMENT.
2. MIN. OF FOUR 2" X 6" RING KEYWAYS REQUIRED WITH TOP KEYWAY CENTERED IN THE SECONDARY CONCRETE POUR.
3. TREMIE SEAL REQUIRED TO BE A MINIMUM OF 84" THICK AND SECONDARY CONCRETE POUR MIN. 16" THICK.
4. TREMIE SEAL TO CURE MINIMUM 72 HOURS PRIOR TO PUMPING OFF WATER TO PREPARE FOR SECONDARY CONCRETE POUR.
5. ENGINEER OF RECORD SHALL SUBMIT SIGNED AND SEALED BUOYANCY CALCULATIONS TO PBCWUD FOR REVIEW AND APPROVAL. FLOATATION CALCULATION SHALL BE BASED ON 25 YR. FLOOD STAGE DURING CONSTRUCTION AND ON 100 YR. FLOOD STAGE WITH SECONDARY POUR INCLUDED.
6. WEIGHT OF TOP SLAB, SECONDARY CONCRETE POUR, PUMPS AND EXTERIOR SKIN FRICTION SHALL NOT BE INCLUDED IN BUOYANCY CALCULATIONS. GROUNDWATER SHALL BE CONSIDERED AT GROUND LEVEL FOR BUOYANCY CALCULATIONS.
7. SEE TYPICAL LIFT STATION DETAILS FOR ADDITIONAL DESIGN AND CONSTRUCTION STANDARDS.
8. WET WELL RISERS SHALL BE MIN. 24", MAX. 72" TALL. CALCAREOUS AGGREGATE REQUIRED (MIN. CaCO3 CONTENT: 65% IN LARGE AGGREGATE, 50% IN CONCRETE SCREENING).
9. CONCRETE BARREL SECTIONS SHALL BE INSTALLED BY CLAMSHELL/CRANE METHOD. DAMAGED SECTIONS WILL NOT BE ACCEPTED.
10. NO CONCRETE SHALL BE PLACED UNLESS WATER LEVEL IN WET WELL IS EQUAL TO OUTSIDE WATER TABLE ELEVATION. INSIDE WATER LEVEL SHALL BE MAINTAINED AT WATER TABLE ELEVATION AT ALL TIMES DURING CONCRETE PLACEMENT.
11. THE CONCRETE TREMIE SEAL RAISE RATE SHOULD BE MAINTAINED BY CONTRACTOR TO ASSURE NO COLD JOINT OCCURS IN SEAL.
12. MIN. PUMP SIZE TO BE 2" MAXIMUM CHUTE SIZE TO BE 12".
13. ENGINEER OF RECORD OR HIS REPRESENTATIVE SHALL BE PRESENT DURING THE WET WELL SETTING AND TREMIE POUR PROCEDURE. ANY CORRECTIVE ACTION FOR LOST SEAL OCCURRENCE SHALL BE DOCUMENTED AND APPROVED BY THE ENGINEER OF RECORD.
14. DROP PIPE MAY BE REQUIRED FOR HIGH FLOW LIFT STATION.

PALM BEACH COUNTY CONSTRUCTION STANDARDS & DETAILS

REVISION/ISSUE DATE

6/2019

LIFT STATION WETWELL SETTING  
TREMIE POUR DETAIL

PAGE NO.

52S

LIFT STATION WETWELL/VALVE VAULT ALUMINUM COVER

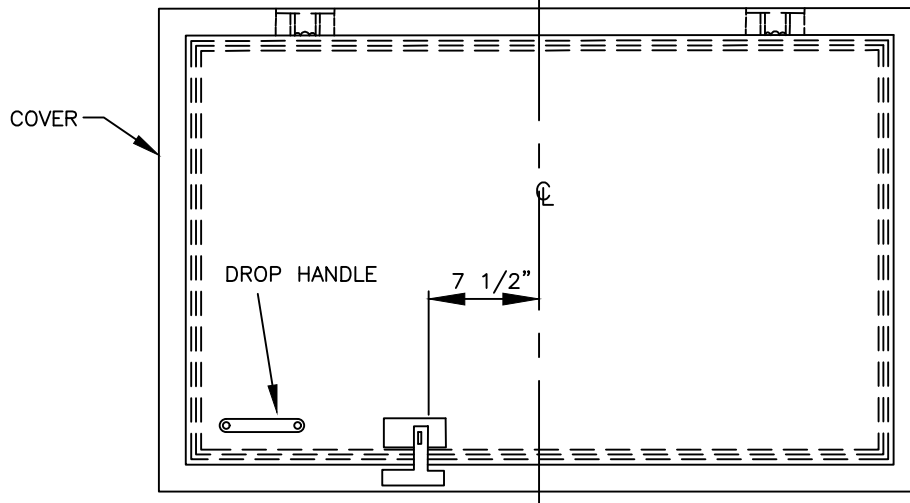

NOTES:

1. COVER TO BE 1/4" ALUMINUM DIAMOND PLATE, HINGED, MIN. LOAD RATING 300 PSF WITH POSITIVE LOCKING ARM AND LOCKING HASP.
2. MINIMUM COVER DIMENSIONS - 36" x 48" FOR 6' DIAMETER WETWELL AND 4'X6' VALVE VAULT.
3. COVER SHALL BE CAST IN PLACE (SEE SPEC SHEET)
4. SPLIT COVER IS REQUIRED FOR LARGER WETWELLS AND/OR VALVE VAULTS.
5. RECESSED HASP IS REQUIRED.
6. TOP AROUND COVER SHALL BE CAST TO THE SAME SIZE AS CONCRETE VALVE VAULT AND CENTERED ON VALVE ASSEMBLY.
7. APPROVED FALL PROTECTION DEVICE IS REQUIRED FOR WET WELL OPENING. THE INSTALLATION SHALL BE PERFORMED BY THE DEVICE MANUFACTURER OR A CONTRACTOR LICENSED BY THE DEVICE MANUFACTURER.

PUMP, FLOAT AND LEVEL TRANSMITTER CABLE RACK

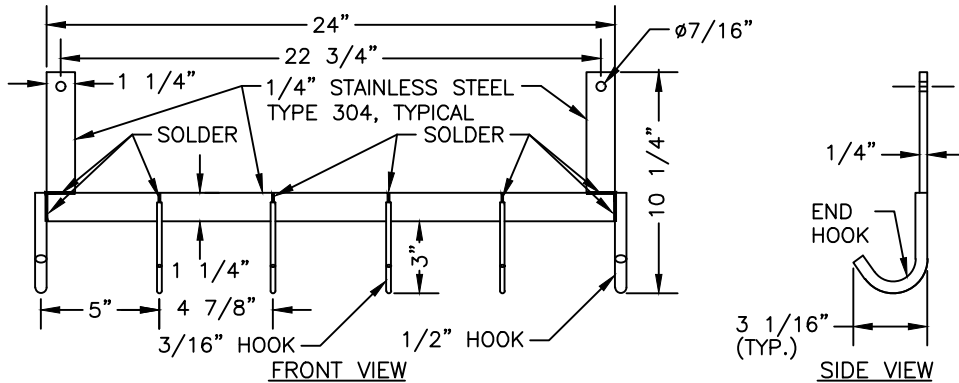

NOTE:

1. WALL OR ACCESS FRAME MOUNTING.
2. ALL COMPONENTS SHALL BE STAINLESS STEEL TYPE 304.
3. TWO RACKS ARE REQUIRED FOR EACH LIFT STATION WET WELL.

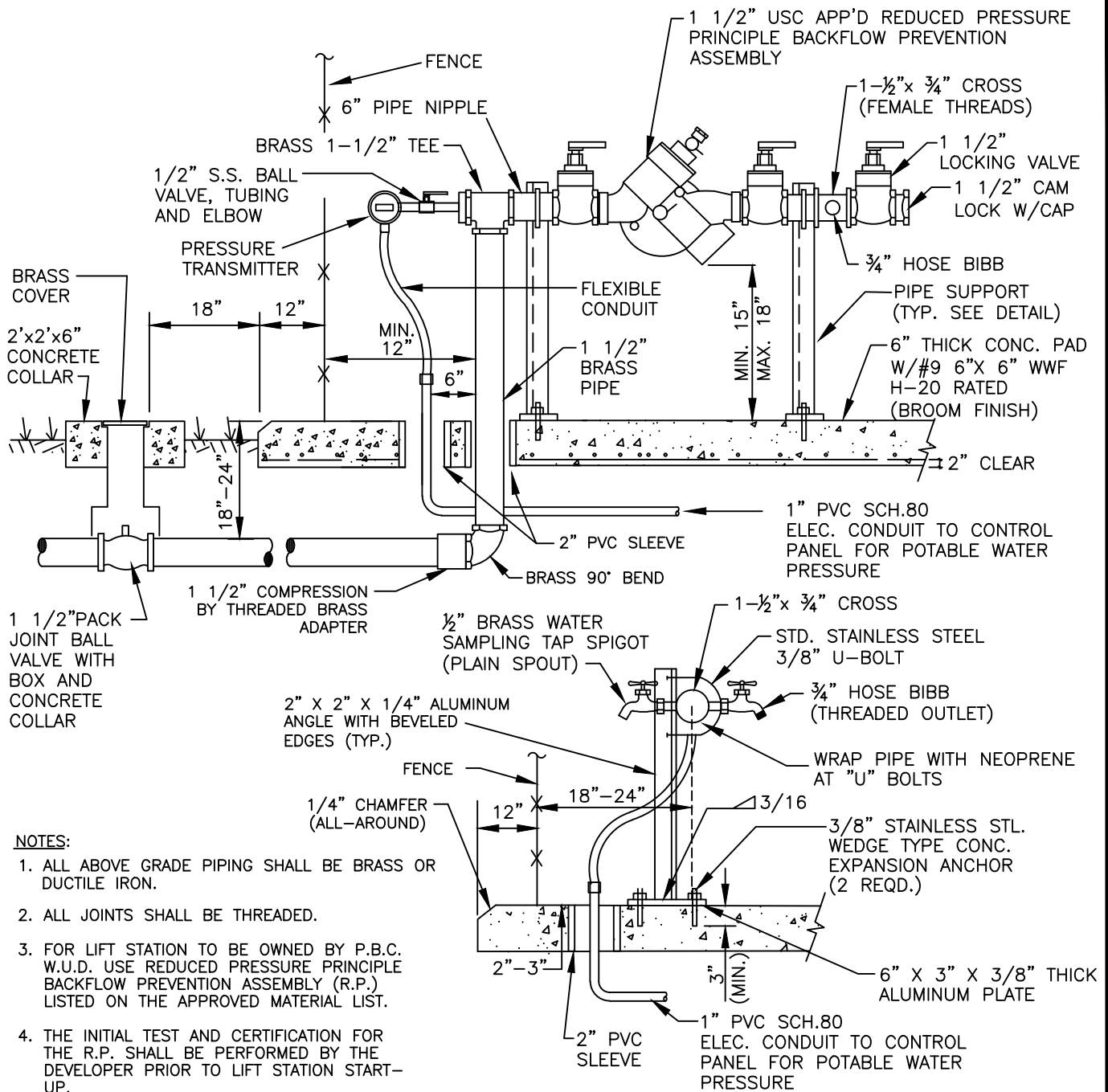

**NOTES:**

1. ALL ABOVE GRADE PIPING SHALL BE BRASS OR DUCTILE IRON.
2. ALL JOINTS SHALL BE THREADED.
3. FOR LIFT STATION TO BE OWNED BY P.B.C. W.U.D. USE REDUCED PRESSURE PRINCIPLE BACKFLOW PREVENTION ASSEMBLY (R.P.) LISTED ON THE APPROVED MATERIAL LIST.
4. THE INITIAL TEST AND CERTIFICATION FOR THE R.P. SHALL BE PERFORMED BY THE DEVELOPER PRIOR TO LIFT STATION START-UP.
5. MIN. 24" CLEARANCE BETWEEN THE ABOVE GROUND ASSEMBLY AND CONTROL PANEL REQUIRED.
6. THREADED AREAS OF CORPORATION STOP AND OTHER FITTINGS SHALL BE SPIRAL WRAPPED WITH TWO WRAPS OF TEFLON TAPE.
7. ALL BRASS AND STAINLESS STEEL FITTINGS AND VALVES SHALL BE LEAD FREE.

PIPE SUPPORT DETAIL

PALM BEACH COUNTY CONSTRUCTION STANDARDS & DETAILS

REVISION/ISSUE DATE

6/2019

HOSE CONNECTION WITH R.P. BACKFLOW PREVENTER FOR LIFT STATION WATER SERVICE

PAGE NO.

54S

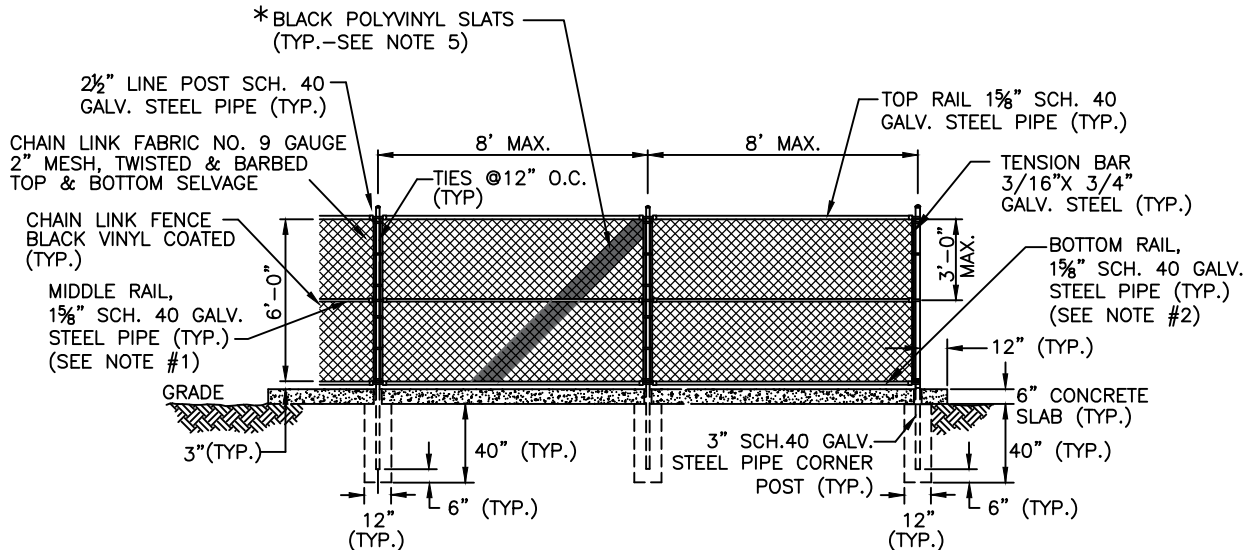

FENCE DETAIL (LIFT STATION)

\* FENCE DESIGN NOTES FOR TREATMENT PLANTS AND MASTER PUMP STATIONS:

- MIDDLE RAIL REQUIRED ONLY AT CORNERS AND CHANGES OF DIRECTION.
- BOTTOM RAIL IS NOT REQUIRED; TENSION WIRE IS REQUIRED WOVEN THROUGH FABRIC AT MAX. 18" SPACING.

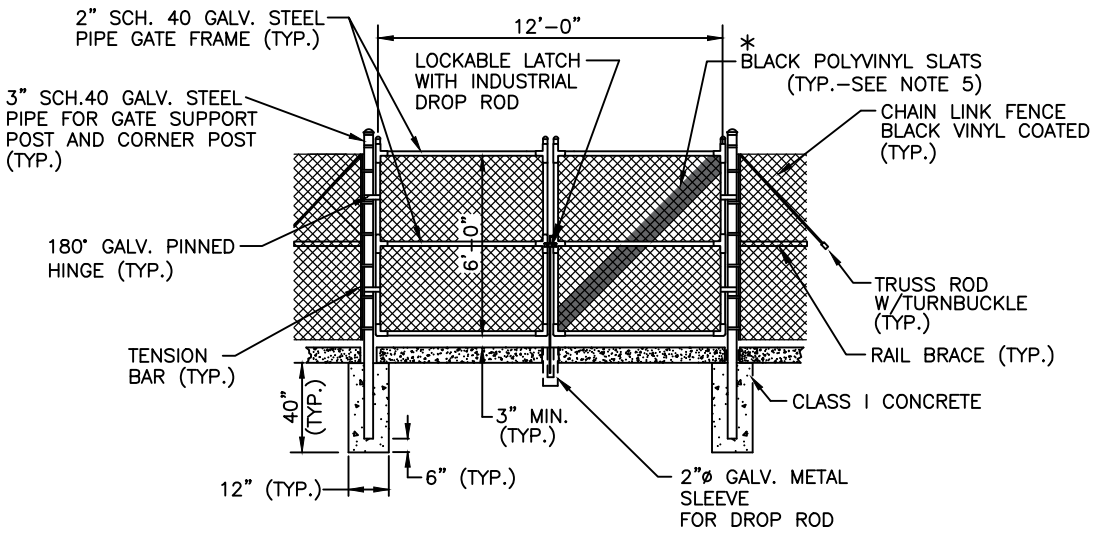

DUAL SWING GATE DETAIL

NOTES:

- BLACK VINYL COATING IS REQUIRED FOR ALL FENCE FABRIC, ALL POSTS, BRACES, RAILS, AND ACCESSORIES.
- ALL POSTS SHALL BE CAPPED WITH GALVANIZED STEEL TOPS. LINE POST TOPS SHALL PROVIDE FOR PASSAGE OF TOP RAIL.
- ALL WELDED JOINTS SHALL BE COATED WITH A 2 PART EPOXY PAINT.
- RAIL SPLICES TO BE LOCATED WITHIN 12" OF A FENCE POST.
- \*BLACK POLYVINYL SLATS INSTALLED DIAGONALLY THROUGHOUT CHAIN LINK FENCE INCLUDING GATE.

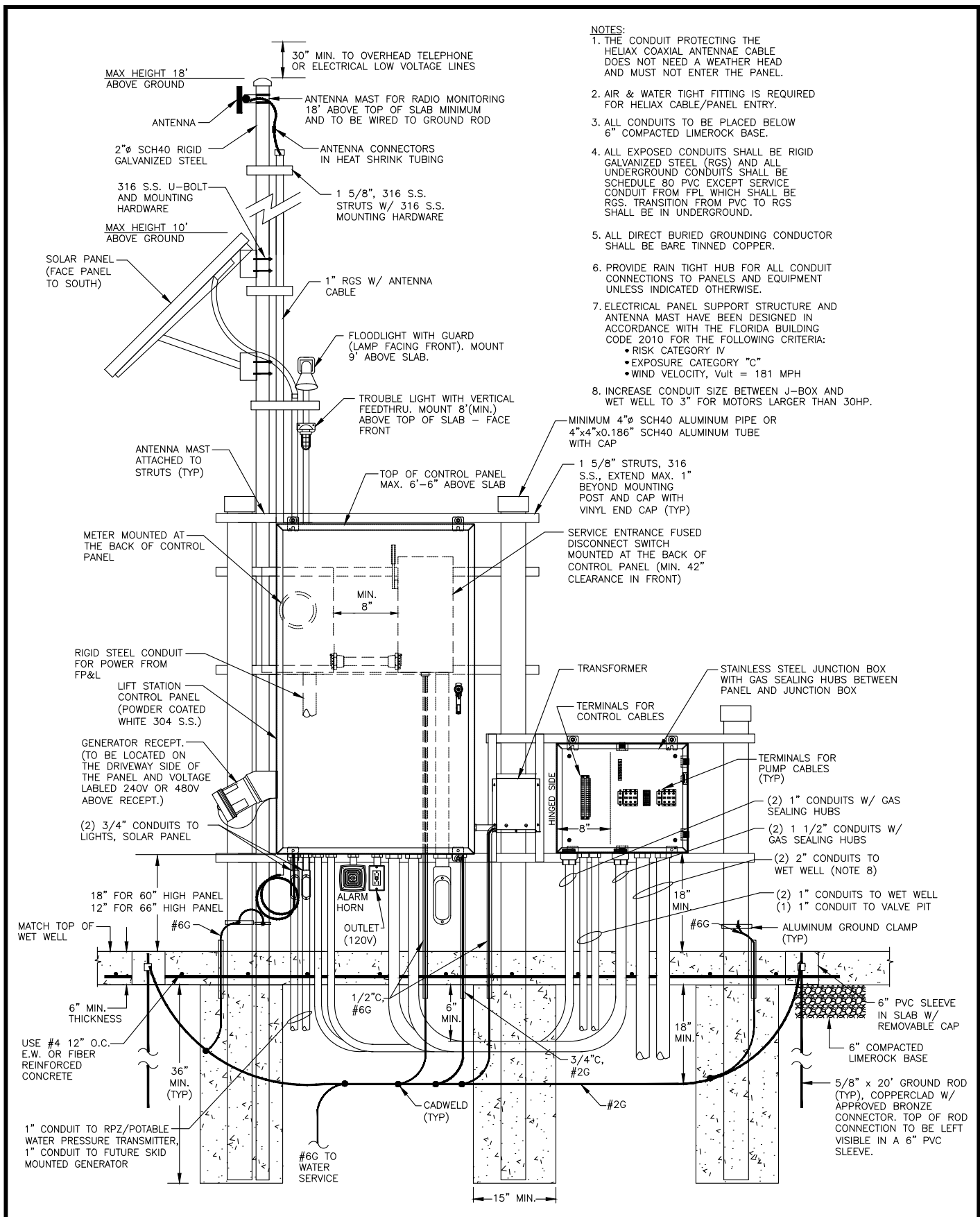

- NOTES:**
1. THE CONDUIT PROTECTING THE HELIAX COAXIAL ANTENNAE CABLE DOES NOT NEED A WEATHER HEAD AND MUST NOT ENTER THE PANEL.
  2. AIR & WATER TIGHT FITTING IS REQUIRED FOR HELIAX CABLE/PANEL ENTRY.
  3. ALL CONDUITS TO BE PLACED BELOW 6" COMPACTED LIMEROCK BASE.
  4. ALL EXPOSED CONDUITS SHALL BE RIGID GALVANIZED STEEL (RGS) AND ALL UNDERGROUND CONDUITS SHALL BE SCHEDULE 80 PVC EXCEPT SERVICE CONDUIT FROM FPL WHICH SHALL BE RGS. TRANSITION FROM PVC TO RGS SHALL BE IN UNDERGROUND.
  5. ALL DIRECT BURIED GROUNDING CONDUCTOR SHALL BE BARE TINNED COPPER.
  6. PROVIDE RAIN TIGHT HUB FOR ALL CONDUIT CONNECTIONS TO PANELS AND EQUIPMENT UNLESS INDICATED OTHERWISE.
  7. ELECTRICAL PANEL SUPPORT STRUCTURE AND ANTENNA MAST HAVE BEEN DESIGNED IN ACCORDANCE WITH THE FLORIDA BUILDING CODE 2010 FOR THE FOLLOWING CRITERIA:
    - RISK CATEGORY IV
    - EXPOSURE CATEGORY "C"
    - WIND VELOCITY,  $V_{ult} = 181$  MPH
  8. INCREASE CONDUIT SIZE BETWEEN J-BOX AND WET WELL TO 3" FOR MOTORS LARGER THAN 30HP.

PALM BEACH COUNTY CONSTRUCTION STANDARDS & DETAILS

REVISION/ISSUE DATE  
01/2023\*

LIFT STATION ELECTRICAL RACK  
FOR GEN. RECEPTACLE LOCATED ON LEFT SIDE

PAGE NO.  
56S



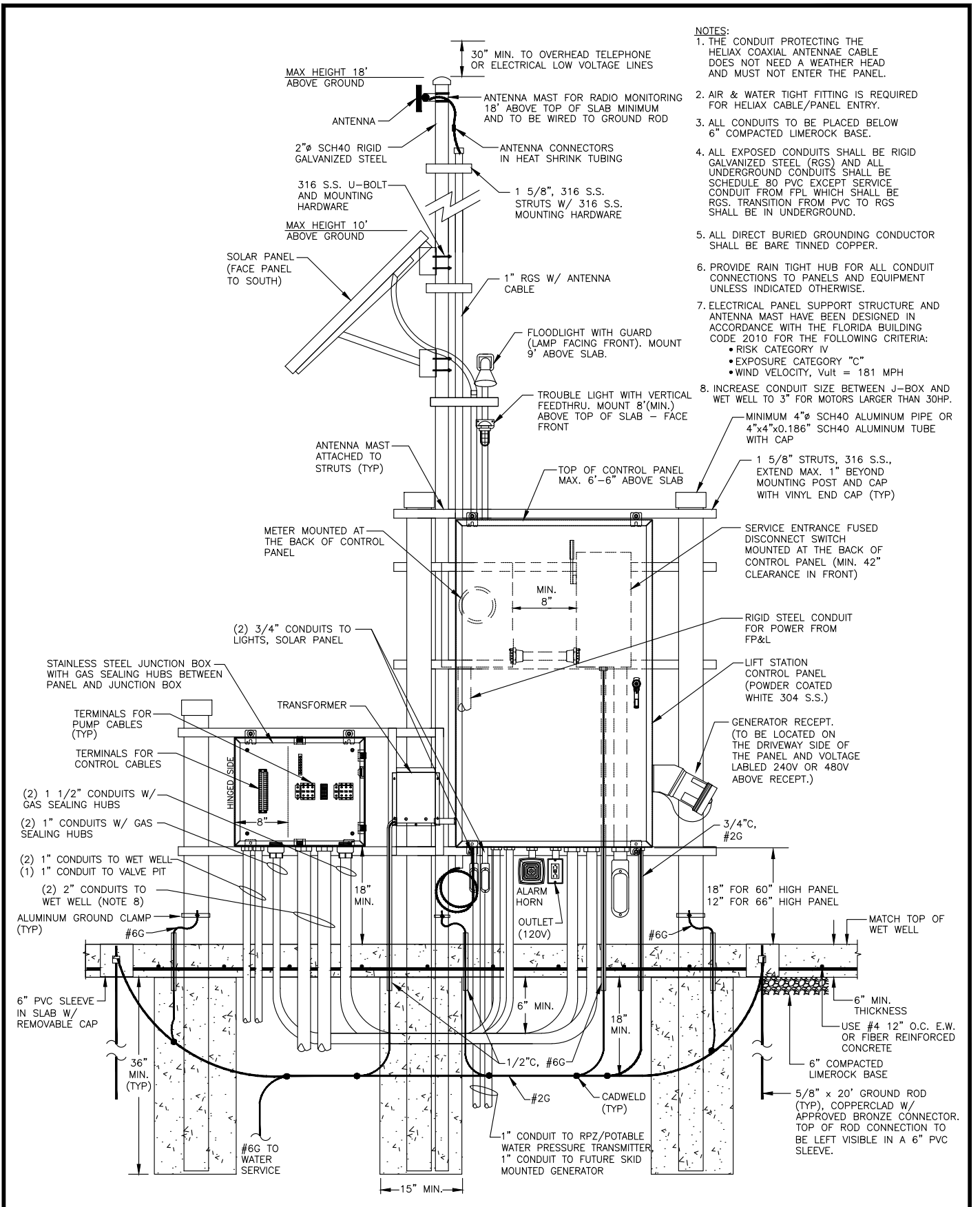

PALM BEACH COUNTY CONSTRUCTION STANDARDS & DETAILS

REVISION/ISSUE DATE

01/2023\*

LIFT STATION ELECTRICAL RACK  
FOR GEN. RECEPTACLE LOCATED ON RIGHT SIDE

PAGE NO.

57S

## INSTALLATION NOTES

1. PANEL, METER, JUNCTION BOX AND 120 VOLT TRANSFORMER ARE TO BE MOUNTED ON STAINLESS STEEL STRUTS, WITH STAINLESS STEEL FASTENING DEVICES, AND SHALL BE SUPPORTED BY MINIMUM OF THREE POSTS, MIN. FOUR (4) INCH DIAMETER PIPE OR MIN. FOUR (4) INCH SQUARE TUBE (ALUMINUM OR STAINLESS STEEL) CAPPED AT THE TOP. PAINT BELOW GRADE SUPPORTS WITH ASPHALTUM PAINT TO FOUR (4) INCHES ABOVE GRADE.
2. PANEL SHALL BE AT 42 INCHES FROM THE WET WELL OPENING MEASURED FROM THE FRONT OF THE PANEL UNLESS OTHERWISE SHOWN IN THE DRAWINGS. FRONT OF CONTROL PANEL SHALL FACE TO THE WET WELL.
3. RADIO TO MATCH PALM BEACH COUNTY'S SYSTEM INCLUDING RUN TIME TRANSMITTAL. LIVE TEST OF THE TELEMETRY SYSTEM MUST BE DONE AND APPROVED AT THE PUMP STATION START-UP. ANTENNA AND CABLE SHALL BE PART OF THE RADIO SYSTEM. ANTENNA SHALL BE SEPARATELY GROUNDED TO THE GROUND ROD OF THE STATION.
4. FABRICATE ANTENNA FROM 21 FEET LENGTH OF 2" DIAMETER SCHEDULE 40 GALVANIZED STEEL CONTINUOUS PIPE. PAINT LOWER 42 INCHES WITH ASPHALTUM PAINT, CAP THE TOP OF PIPE.
5. RUN (1) INCH RIGID GALVANIZED CONDUIT UP THE MAST FOR THE ANTENNA CABLE TO WITHIN 16 INCHES OF THE TOP. RUN SECOND 3/4 INCH CONDUIT UP THE MAST FOR ALARM AND FLOOD LIGHTS AS SHOWN. RUN THIRD 3/4 INCH CONDUIT UP THE MAST FOR SOLAR PANEL. USE STAINLESS STEEL UNISTRUT AND CLAMPS TO HOLD CONDUITS TO THE MAST.
6. MOUNT FLOOD LIGHT AND FLASHING RED LIGHT ON THE ANTENNA MAST AT NINE (9) FEET AND EIGHT (8) FEET ABOVE GRADE.
7. CONDUIT TO THE POWER COMPANY SERVICE POINT SHALL BE RIGID GALVANIZE WITH ASPHALTUM PAINT ON ALL FITTINGS AND ON ALL RISERS TO 12 INCHES ABOVE GRADE. CONDUIT FROM SERVICE ENTRANCE FUSED DISCONNECT SWITCH TO THE PANEL SHALL BE RIGID GALVANIZED CONDUIT ENTERING THE BOTTOM OF THE PANEL. ALL WIRE SHALL BE COPPER. HIGH LEG ON 240 VOLT SHALL BE TAPED ORANGE AND PUT ON CENTRAL TERMINAL IN PANEL AND RIGHT TERMINAL IN METER.
8. PROVIDE PVC SCHEDULE 80 CONDUITS WITH SWEEP BENDS FROM THE JUNCTION BOX TO THE WET WELL.
9. SUPPORT PUMP CABLES WITH STAINLESS SPLIT BASKET KELLUM (OR EQUAL) GRIPS IN WET WELL. SUPPORT FLOAT CABLE ON S.S. THIMBLE FROM THE RACK. ALL HARDWARE IN THE WET WELL AND ALL FASTENERS SHALL BE STAINLESS STEEL. CABLES SHALL BE CONTINUOUS FROM THE JUNCTION BOX TO THE MOTORS OR SENSORS.
10. WHEN CONNECTIONS ARE COMPLETE IN THE JUNCTION BOX, COAT THE TERMINAL BLOCKS AND WIRE ENDS WITH PROTECTIVE COMPOUND, NO-OXIDE OR EQUAL, TO PREVENT CORROSION.
11. PROVIDE 3/4 INCH RIGID GALVANIZED CONDUIT FROM THE PANEL TO 120 VOLT TRANSFORMER. ALL CONDUITS ENTER BOTTOM OF THE PANEL UNLESS OTHERWISE SHOWN. SEAL ALL CONDUITS WITH DUCT SEAL TO KEEP OUT MOISTURE.
12. PAINT PVC PIPES, CONDUITS AND ANY PARTS NOT STAINLESS OR ALUMINUM WITH TWO (2) COATS OF ALUMINUM PAINT.
13. LIFT STATION START UP SHALL BE PERFORMED DURING THE ANTICIPATED PEAK FLOW CONDITIONS. TEST AS FOLLOWS (PUMP SUPPLIER'S FIELD REPRESENTATIVE MUST BE PRESENT AT THE START UP).
  - A. MEGGER MOTORS, MOTORS SHALL BE 20 MEGOHMS OR MORE TO GROUND, DO NOT MEGGER LOW VOLTAGE CONTROLS.
  - B. CHECK VOLTAGE, CHECK PUMP ROTATION, RECORD VOLTAGE AND AMPS UNDER LOAD.
  - C. DEMONSTRATE PROPER OPERATION OF ALL CONTROLS.
  - D. CONDUCT DRAWDOWN TESTS AS REQUIRED TO CONFIRM PROPER PUMP/IMPELLER INSTALLATION.
  - E. CHECK OPERATION WITH OWNER'S PORTABLE GENERATOR CHANGE WIRE CONNECTIONS IN THE PANEL TO GIVE CORRECT ROTATION.
14. TEST AND DEMONSTRATE PROPER OPERATION OF THE RADIO TELEMETRY SYSTEM. SUPPLIER'S FIELD REPRESENTATIVE SHALL MOUNT AND CONNECT THE ANTENNA AND MAKE THE FINAL CONNECTIONS TO THE SYSTEM.
15. PROVIDE LIQUID TIGHT NONMETALLIC FLEXIBLE CONDUIT (CARLON CARFLEX) WITH SEAL TYPE FITTINGS FOR LEVEL TRANSMITTER CABLE INSIDE THE WET WELL.
16. PROVIDE GAS SEALOFF WITH CHICO COMPOUND FOR CONDUITS BETWEEN JUNCTION BOX AND CONTROL PANEL.
17. ALL STAINLESS STEEL SHALL BE 316 UNLESS INDICATED OTHERWISE.
18. PHASE SEQUENCE IN CONTROL PANEL SHALL BE SETUP FOR CLOCKWISE ROTATION TO MATCH THE ROTATION OF PBCWUD PORTABLE STANDBY GENERATORS.

## PALM BEACH COUNTY CONSTRUCTION STANDARDS & DETAILS

REVISION/ISSUE DATE

01/2023\*

## CONTROL PANEL INSTALLATION NOTES

PAGE NO.

585

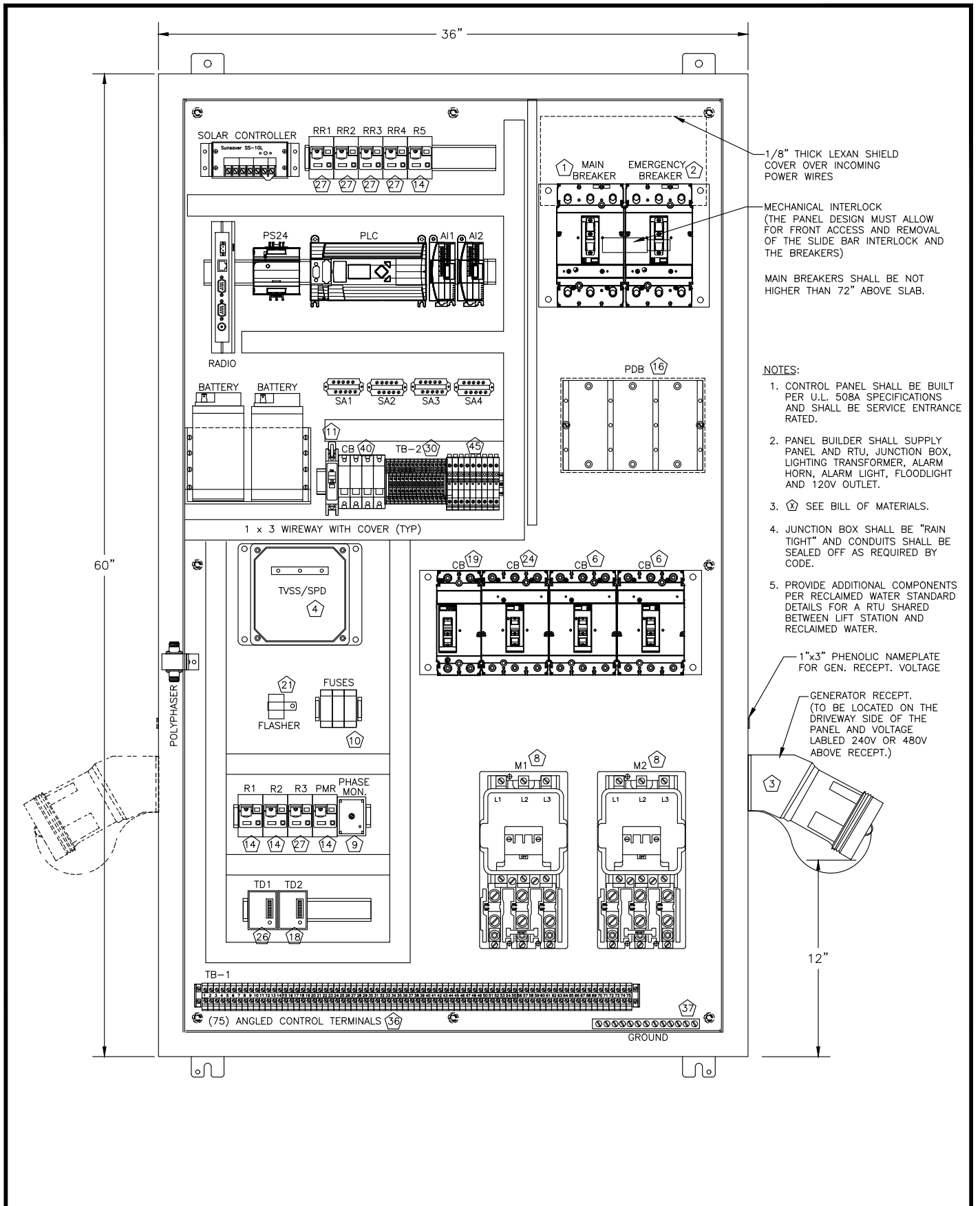

1/8" THICK LEXAN SHIELD COVER OVER INCOMING POWER WIRES

MECHANICAL INTERLOCK (THE PANEL DESIGN MUST ALLOW FOR FRONT ACCESS AND REMOVAL OF THE SLIDE BAR INTERLOCK AND THE BREAKERS)

MAIN BREAKERS SHALL BE NOT HIGHER THAN 72" ABOVE SLAB.

NOTES:

1. CONTROL PANEL SHALL BE BUILT PER U.L. 508A SPECIFICATIONS AND SHALL BE SERVICE ENTRANCE RATED.
2. PANEL BUILDER SHALL SUPPLY PANEL AND RTU, JUNCTION BOX, LIGHTING TRANSFORMER, ALARM HORN, ALARM LIGHT, FLOODLIGHT AND 120V OUTLET.
3. ⓧ SEE BILL OF MATERIALS.
4. JUNCTION BOX SHALL BE "RAIN TIGHT" AND CONDUITS SHALL BE SEALED OFF AS REQUIRED BY CODE.
5. PROVIDE ADDITIONAL COMPONENTS PER RECLAIMED WATER STANDARD DETAILS FOR A RTU SHARED BETWEEN LIFT STATION AND RECLAIMED WATER.

1"x3" PHENOLIC NAMEPLATE FOR GEN. RECEPT. VOLTAGE

GENERATOR RECEPT. (TO BE LOCATED ON THE DRIVEWAY SIDE OF THE PANEL AND VOLTAGE LABELED 240V OR 480V ABOVE RECEPT.)

12"

PALM BEACH COUNTY CONSTRUCTION STANDARDS & DETAILS

REVISION/ISSUE DATE  
01/2023\*

LIFT STATION CONTROL PANEL INTERNAL LAYOUT  
FOR MOTORS SMALLER THAN 20HP

PAGE NO.  
59S

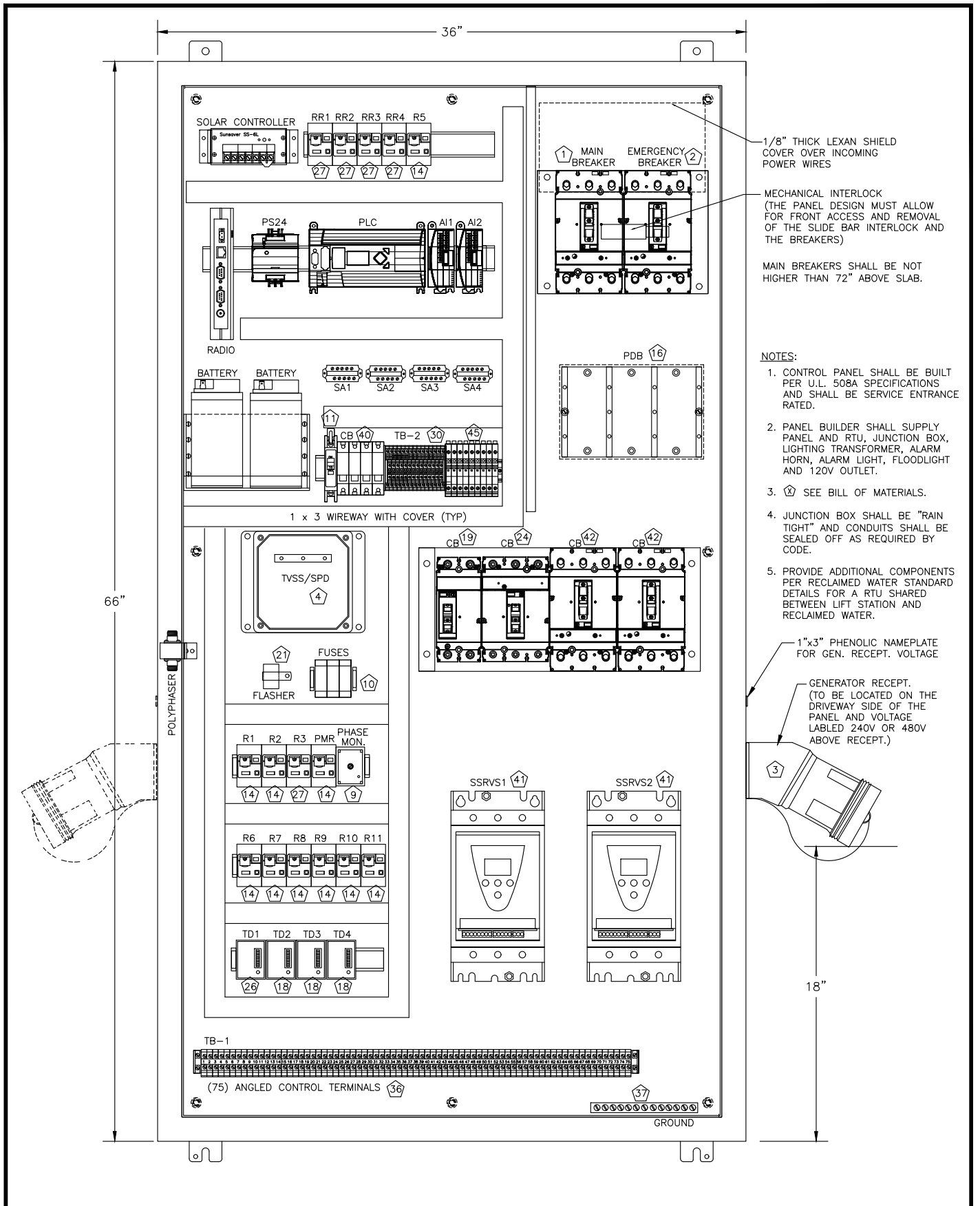

1/8" THICK LEXAN SHIELD COVER OVER INCOMING POWER WIRES

MECHANICAL INTERLOCK (THE PANEL DESIGN MUST ALLOW FOR FRONT ACCESS AND REMOVAL OF THE SLIDE BAR INTERLOCK AND THE BREAKERS)

MAIN BREAKERS SHALL BE NOT HIGHER THAN 72" ABOVE SLAB.

- NOTES:
- CONTROL PANEL SHALL BE BUILT PER U.L. 508A SPECIFICATIONS AND SHALL BE SERVICE ENTRANCE RATED.
  - PANEL BUILDER SHALL SUPPLY PANEL AND RTU, JUNCTION BOX, LIGHTING TRANSFORMER, ALARM HORN, ALARM LIGHT, FLOODLIGHT AND 120V OUTLET.
  - SEE BILL OF MATERIALS.
  - JUNCTION BOX SHALL BE "RAIN TIGHT" AND CONDUITS SHALL BE SEALED OFF AS REQUIRED BY CODE.
  - PROVIDE ADDITIONAL COMPONENTS PER RECLAIMED WATER STANDARD DETAILS FOR A RTU SHARED BETWEEN LIFT STATION AND RECLAIMED WATER.

1"x3" PHENOLIC NAMEPLATE FOR GEN. RECEIPT VOLTAGE

GENERATOR RECEIPT. (TO BE LOCATED ON THE DRIVEWAY SIDE OF THE PANEL AND VOLTAGE LABELED 240V OR 480V ABOVE RECEIPT.)

PALM BEACH COUNTY CONSTRUCTION STANDARDS & DETAILS

REVISION/ISSUE DATE  
01/2023\*

LIFT STATION CONTROL PANEL INTERNAL LAYOUT  
FOR 20HP MOTORS AND LARGER

PAGE NO.  
60S

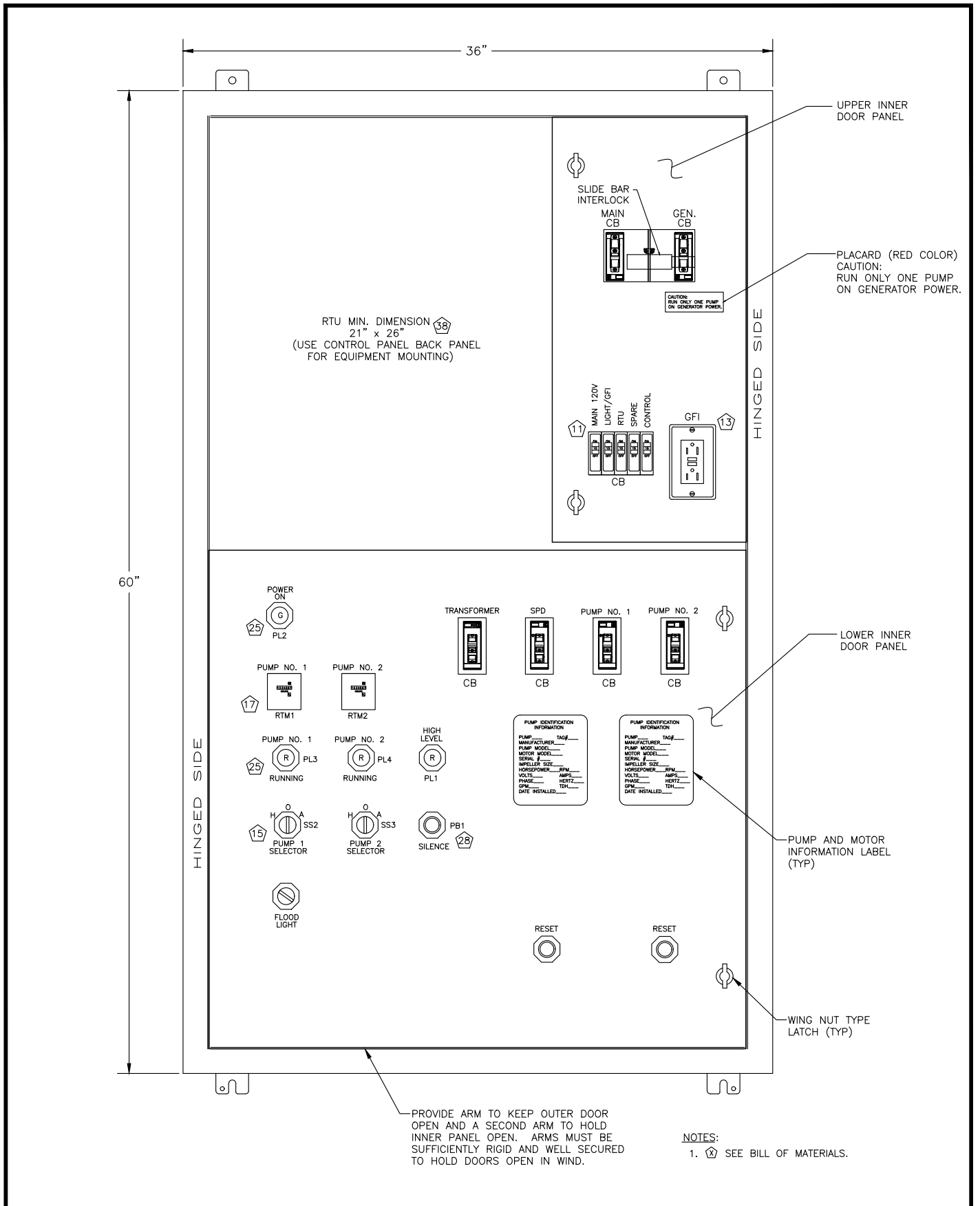

PALM BEACH COUNTY CONSTRUCTION STANDARDS & DETAILS

REVISION/ISSUE DATE  
01/2023\*

LIFT STATION CONTROL PANEL INNER DOORS  
FOR MOTORS SMALLER THAN 20HP

PAGE NO.  
61S

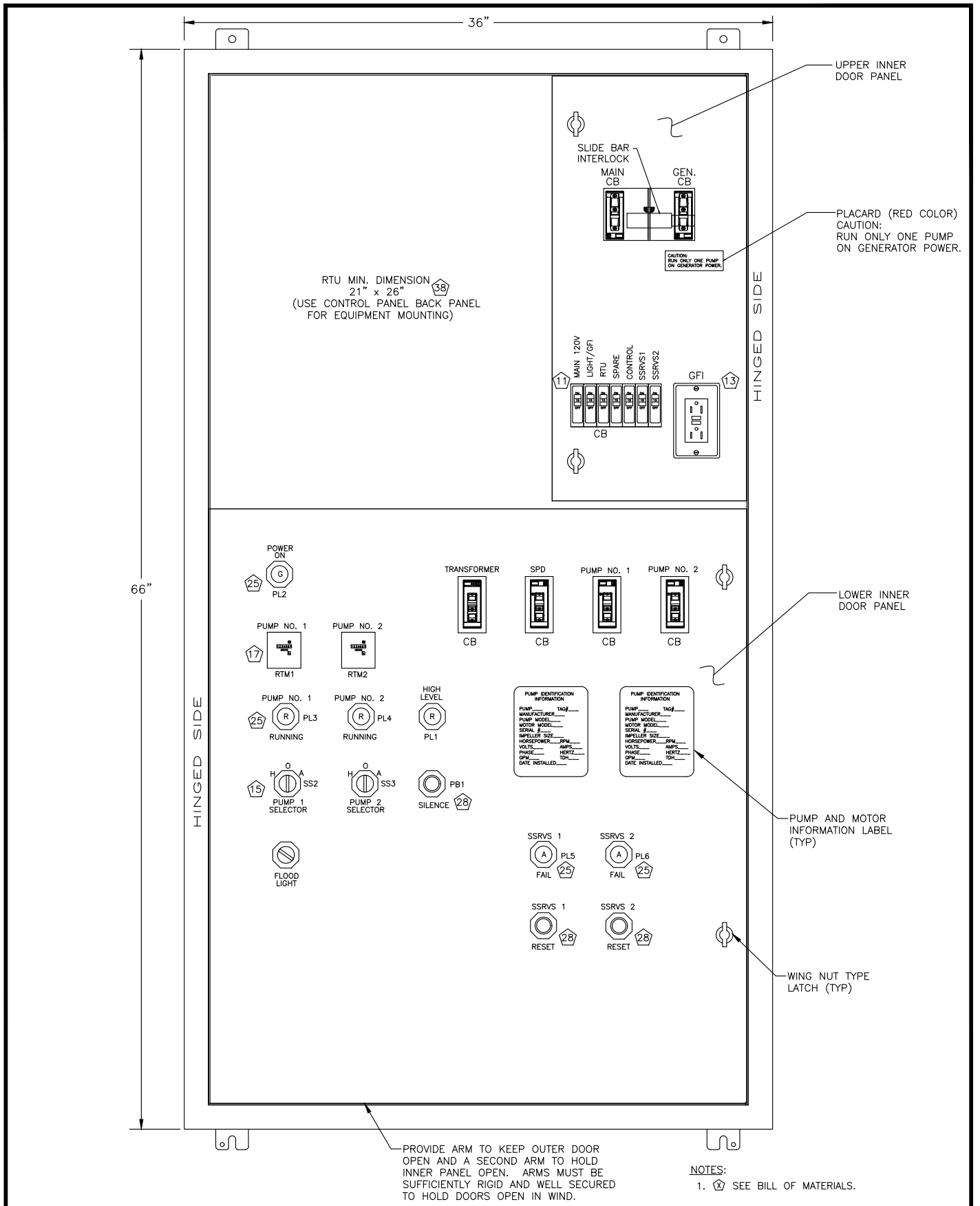

PALM BEACH COUNTY CONSTRUCTION STANDARDS & DETAILS

REVISION/ISSUE DATE  
01/2023\*

LIFT STATION CONTROL PANEL INNER DOORS  
FOR 20HP MOTORS AND LARGER

PAGE NO.  
62S

A. Panel Builder

1. The panel builder shall be experienced in the construction of lift station control panels, shall have a UL approved shop. Panel shall be UL listed and UL labeled as service entrance equipment.
2. The panel builder shall warrant the panel for one (1) full year minimum from the date of final project certification.
3. The panel builder or qualified technical representative shall check-out and test the panel as part of the lift station start-up.

B. Panel Components

1. The panel components are specified on the drawings with the exception of items described in these specifications. Items are listed by manufacturer and catalog number, other equal quality components may be substituted but they must be fully interchangeable with those specified in size, function, mounting dimensions, plug in connections, and ampacity. Any substitutions or changes must be approved in advance and in writing by the utility department. All components shall be new with no signs or evidence of corrosion.

C. Enclosure

1. The panel with size 1, or 2 starters shall be minimum 36 inch wide x 60 inch high x 12 inch deep (36"W x 60"H x 12"D). The panel with soft starters shall be minimum 36 inch wide x 66 inch high x 16 inch deep (36"W x 66"H x 16"D). Larger panel may be installed if required by UL and NEC specifications for service intended. A shop drawing must be submitted prior to preconstruction meeting. Top of panel shall not be higher than 6'-6" above slab, unless approved in advance by the department. The panel shall be of a modified NEMA 3R construction with the following features:
  - a. Constructed of 304 stainless steel 14 gauge. Enclosure shall have powder coated white stainless steel body and door. All seams to be continuously welded, spot welded panels will not be accepted.
  - b. All external hardware shall be stainless steel with piano hinge, three-point latch with roller fitting top and bottom and single handle with padlock fitting and stainless steel external parts.
  - c. Full length welded drip shield to deflect water from the door, a continuous closed cell neoprene gasket on the door.
  - d. Blank outer door with dead front inner door of 1/8" thick aluminum hinged on the left with the operators controls mounted on or projecting through it.
  - e. Provide painted steel or Aluminum back mounting plate for heavy components (min. .090 thickness).
  - f. A removable min. 1/8 inch thick lexan cover shall be provided on the incoming line terminals.
  - g. The outer door is to have nine inch by eleven inch (9" x 11") stainless steel or aluminum pocket for log book, tack weld to door.
  - h. Arms and latches shall hold both outer door and inner door in an open position, these must be sufficiently rigid and secure to hold doors open under windy weather conditions any may be placed one on top and one on bottom.
  - i. Sliding locking bar to allow only main or emergency breaker to be closed. Bar shall be aluminum with stainless steel hardware.
  - j. No penetration through the panel will be allowed except for conduits on bottom, and for generator receptacle and transformer conduit on the side, i.e. no screws through panel, outer door or frame.
2. The enclosure shall be the product of a UL approved manufacturer and shall be a modified NEMA-3R enclosure. Manufacturer shall be Hoffman or approved equal. Enclosure shall have lugs for mounting.

PALM BEACH COUNTY CONSTRUCTION STANDARDS & DETAILS

REVISION/ISSUE DATE

01/2023\*

ELECTRICAL PANEL  
SPECIFICATIONS (SHT 1 OF 3)

PAGE NO.

635

D. Wiring

1. All wiring shall be copper THWN or approved equal, AWG 14 minimum. Color code wires as follows:

Ground	—	Green
Grounded Neutral	—	White
120 Volt Power	—	Black
Control	—	Red
24 Volt Control	—	Blue

Different control wiring colors are acceptable if clearly identified. Power wiring shall be kept separate from control wiring, and shall be identified by phase. The high leg shall be the center terminal on the main breaker.
2. All wires shall be numbered with machine made plastic wrap around labels at both ends.
3. All external connection and internal connections, where shown on the drawings, shall be brought to the numbered terminals. All PLC inputs and outputs shall be brought to the terminal blocks even if not used.
4. Wiring shall be enclosed in panduct or equivalent wireways and wiring between the doors and the panel shall be enclosed in a spiral wrap or approved equal with sufficient slack to allow full opening of the door.
5. Wiring shall be secured with screw-on tabs, tabs with adhesives shall not be used.
6. All wiring shall be front accessible.
7. All electrical wiring must meet or exceed National Electric Code and Local Code Standards.
8. Any place that electrical wire passes through a metal cover or shield, insulating grommet is required to protect the wire.

E. Component Mounting

1. All components shall be securely mounted with stainless steel hardware. Self tapping screws are not acceptable.
2. All relay bases shall be front mounted with screw terminals, no soldered connections shall be used. All base terminals shall be numbered to correspond to relay numbers. Where plug-in components are not firmly secured in bases, hold down clamps shall be provided.

F. Identification

1. All components shall be identified in accordance with the schematic diagram, using permanent name tags on the panel of laminated micarta or approved equal. The permanent name tags shall be securely attached and in a position where they are clearly visible.
2. All operator's controls shall be provided with laminated micarta name tags attached with stainless steel screws, with minimum lettering height of 1/8 inch.
3. Provide a laminated schematic drawing attached to the inside of the outer door – minimum size 11 inches by 17 inches (11" x 17").
4. Attach a separate stick-on label showing the following details:

<u>PUMP</u>	<u>MOTOR</u>
a. Brand	a. Horsepower
b. Catalog number	b. Speed
c. Impeller number and size	c. Voltage
d. Design head	d. Full load amps
e. G.P.M.	e. Catalog number
f. Serial numbers	f. Serial numbers
5. Pump ID tags shall be provided by the PBCWUD and installed by the Contractor. Request via PBCWUD pump shop prior to pump installation.

PALM BEACH COUNTY CONSTRUCTION STANDARDS & DETAILS

REVISION/ISSUE DATE

01/2023\*

ELECTRICAL PANEL  
SPECIFICATIONS (SHT 2 OF 3)

PAGE NO.

64S



G. Junction Box

1. The "RAIN TIGHT" junction box shall be NEMA-4X, 316 stainless steel, Hoffman or approved equal with padlock fitting, continuous hinge clamped cover construction. Junction box shall be minimum of 24 inches wide by 20 inches high by 8 inches deep (24" W x 20" H x 8" D) and shall have a stainless steel or aluminum back mounting plate for terminal blocks. Provide a stainless steel or aluminum partition between the control and power terminals as shown on the drawings. Junction box design shall allow for venting as required by code.
2. Provide gas sealing hubs, conduit, terminals, and wire as shown on the drawings. Provide four (4) extra control wires and (2) extra twisted shield pair cables for future.
3. Pour seals into gas sealing hubs between panel and junction box with compound approved by seal manufacturer.
4. Provide plated copper ground lug and wire to the panel ground.

H. Drawings

1. Panel builder shall provide the following drawings:
  - a. Schematic drawing showing all components. Components shall be properly identified by number and function. All connections shall be numbered to correspond to the component numbers. All wires and terminals shall be clearly numbered and identified.
  - b. Bill of material listing all parts as follows, in tabular form:
    - 1) Drawing Reference
    - 2) Description
    - 3) Manufacturer
    - 4) Catalog Number
    - 5) Type
    - 6) Notes
  - c. Layout drawing showing the front with the operators panel and with the panel open. Layout drawings shall also show the outside dimensions of the panels and dimensioned mounting supports.
  - d. Plastic encased drawing inside the panel as previously noted herein.
2. Drawings shall be clear and readable and a minimum of 11 inches by 17 inches (11" x 17"). "Fuzzy" reductions will be rejected.

I. Loose Components

1. Ship the following for mounting by the site electrician.
  - a. Alarm Light – Item 22
  - b. Outside Floodlight – Item 12
  - c. 120 Volt Transformer – Item 7
  - d. Junction Box – Item 33
  - e. Alarm Horn – Item 23
  - f. Outlet 120V – Item 39

J. Soft Starters (SSRVS – item 41)

1. Soft Starters shall be provided in the control panel for the lift stations which have 20HP motors and larger. Soft Starters shall be solid state reduced voltage starter type with integral bypass, display and optional fan. Soft starters line voltage shall be rated from 240V to 480V, 3Ø. Control supply voltage, control logic inputs and fan supply voltage for soft starters shall be 120V. Soft Starters shall be rated to operate at higher ambient temperature. Oversize soft starter rating minimum one size higher than motor HP. All soft starter settings shall be set and adjusted properly for functional operation of lift station. Set ramp up time to "5 sec", ramp down time to "Off", overload protection to "On", over current time delay to "5 sec", under and over voltage time delay to "10 sec", the line voltage, and motor full load amp per motor nameplate, etc. Disable all the protection features including phase loss, phase reverse, under, unbalance and ground current. Only overload protection shall be enable.

PALM BEACH COUNTY CONSTRUCTION STANDARDS & DETAILS

REVISION/ISSUE DATE

01/2023\*

ELECTRICAL PANEL  
SPECIFICATIONS (SHT 3 OF 3)

PAGE NO.

65S

## BILL OF MATERIALS (CONTROL PANEL)

(ALL ELECTRICAL COMPONENTS AND ASSEMBLIES MUST BE UL LISTED/APPROVED)

ITEM	NAME	DESCRIPTION	MANUFACTURER	TYPE
1	Main Breaker	3p-100 Amp, 240 volt w/ Auxiliary contact, 25k AIC (minimum)	Square D	Powerpact H-Frame
2	Generator Breaker	(Same as Main)		
3	Generator Receptacle	4-wire, 100 Amp	Russellstoll	JRS1034HR
4	TVSS/SPD	120/240 volt, 3 phase, 4 wire high leg delta	ASCO	430240HP10ACSJ1
5	Level Transmitter	Radar level sensor, two-wire Range: 0 - 23 feet, Cable 30 feet w/ 316 S.S. L-shape mounting bracket	Vega Endress & Hauser	Vegapuls C21 FMR20
6	Motor Circuit Breaker	Magnetic only w/ Auxiliary Contact size per motor (25k AIC min.)	Square D	Powerpact H-Frame
7	120 volt Transformer	3 kVA, 240/480 to 120/240 Painted 316 Stainless Steel	Square D	3S1FSS
8	Motor Starter	3p, NEMA size 1 (min.) w/Transient Suppression Module	Square D	Class 8536
9	Phase Monitor	Plug-in 8 pin 240 volt, 3p	Diversified	SUA-230-ALAU
10	Fuse	600 volt, amps as shown w/ Finger-safe Fuseholder	Bussmann	KTK for Phase Monitor
11	120V Circuit Breakers	Thermal Magnetic	Square D	Type Q0U
12	Outside Floodlight	White LED 15W, 1600 Lumen light Bulb	RAB Lighting	HB101W w/ HG1W guard
13	Panel Outlet	120V GFI Duplex, 20A, Spec Grade	Hubbell	GF 5362I
14	Control Relay 120Vac	Plug-in, Round Base, 11 Cylindrical Pin with LED light, 120V	Square D	RUMC3AB2F7
15	Pump Selector	Hand-Off-Auto (Manual Return)	Square D	SKS43B
16	Power Distribution Block	3p - (2) 500KCM - #4, (8) #2/0 - #14	Marathon	1453586 with lexan cover
17	Running Time	2 inch Square, 120 volt	Redington	711-0190
18	Time Delay Relay Delay on Make	1 to 1023 Second, 8 Pin Base, 120 volt	SSAC	TDM120AL
19	Transformer Breaker	2p-30 Amps, 25k AIC (Min.)	Diversified	TBC-120-ABA
20	Motor Temperature and Moisture Detector	Relay - 120Vac or 24Vdc (Provide if required)	Square D	HGL 26030
21	Flasher	2 amp, 75 F.P.M.	As Specified by Pump Supplier	
22	Outside Alarm Light	Red Globe with Guard, 100W Lamp	SSAC	FS127
23	Outside Alarm Horn	120 volt Weatherproof	RAB Lighting	VXBR100DG w/ GL100R Globe
24	TVSS/SPD Breaker	3p-30 Amps, 25k AIC (Min.)	Edwards Signals	876-N5
25	Pilot Lights 120 Volt	LED Pilot Light	Square D	HGL 36030
26	Time Delay Relay Delay On Break	1 to 1023 Second, 11 Pin Base, 120 volt	Square D	Type SK
27	Control Relay 24Vdc	DPDT 8 Cylindrical Pin, Round base with LED light, 24Vdc	SSAC	TDB120ALD
28	Silence Pushbutton	Oiltight	Diversified	TBD-120-ABAD
29	Float Switch	Encapsulated Switch, Integral cord w/ NO and NC Contacts, Min. 40' cord	Square D	RUMC2AB2BD
30	RTU Wire Terminal	Feed-Through Modular Block	Anchor Scientific	Type SKR1UH5
31	Junction Box Power Terminal Blocks	Insulated 3pole Power Splicer	Flygt	GS140NONC
32	Control Panel	Min. 36"Wx60"Hx12"D	Phoenix	ENM-10
33	Junction Box	24"Wx20"Hx8"D	Marathon	UTTB4
34	Gas Sealing Hub	Sealing Hub, Size as shown		1323572 for phase 1320572 for ground
35	Raintight Conduit Hub	Size as shown	Hoffman	See Panel Specification
36	Control Wire Terminal	Rail Mount w/ angled bracket	Hoffman	See Panel Specification
37	Ground Terminal	Copper Tin Plated	Crouse Hinds	ES65 AND ES53
38	RTU	Remote Telemetry Unit	O.Z. Gedney	CHM
			Square D	Class 9080 GR6
			Square D	Class 9080
			Curry Control Co.	PBCRTU2019
			ESC	PBCRTU2019
			C.C. Controls	PBCRTU2019
			AES	PBCRTU2019
			Unitron	PBCRTU2019
			Champion Controls Inc.	PBCRTU2019
39	Exterior Outlet	120V GFI Duplex, 20A, Spec Grade w/weatherproof box and cover	Hubbell	GF 5362I
			Box: Crouse Hinds	FD2
			Cover: Crouse Hinds	TP7240
40	DC Miniature Breaker	Pole and Amp As Shown	Square D	C60 Multi 9
41	Soft Starter/SSRVS	w/ integral bypass and optional fan	Square D	ATS22D75S6U w/ fan
42	Motor Circuit Breaker w/ Shunt Trip	Magnetic only 3p 600 volt size per motor (25k AIC min.)	Square D	Powerpact H-Frame
43	Service Entrance Fused Disconnect Switch	600V, 3p, Nema 4X 316SS w/ class RK1 fuses (size same as Main)	Square D	H363NSS
44	Service Fuse	600V, Dual element, time delay fuses class RK1 (size same as Main)	Bussmann	LPS-RK
45	RTU Fuse Terminal	Fuse terminal block w/ LED blown fuse indicator, Fuse size as shown	Phoenix	3046090
			Sprecher Schuh	V7-H5
46	Pressure Transmitter	Range: 0-100 psi, w/ Display	ABB	261GSDKTN51EAL1M5
47	Diaphragm Seal	Threaded Diaphragm Seal, 316 SS, Silicone Filled, 1/2" FNPT	Ashcroft	50-201SS-04T-XCKSE

### PALM BEACH COUNTY CONSTRUCTION STANDARDS & DETAILS

REVISION/ISSUE DATE

01/2023\*

CONTROL PANEL  
BILL OF MATERIALS

PAGE NO.

665

NOTES ON 240V PANELS:

- A. This is the minimum size pump station panel for under 15 hp at 240 volts, 3p. For larger than 15 hp items 1, 2, 6, and 8 change. Minimum service size 100 AMP. Minimum service wires and conduit 3-#2, 1-#4G, 2" C. Minimum wires and conduits for motors between control panel and junction box are 3-#8, 1-#10G, 1 1/2" C plus 4-#14 for motor temperature and moisture sensors.
- B. Short circuit amps rating of circuit breaker and panel shall equal or exceed system S.C. amps. Contractor shall confirm this value with the power company and order the panel accordingly. In addition, the minimum S.C. amp rating of the panel shall be as follows:
- For 100 amps                      25,000 amps  
For 101 to 250 amps            42,000 amps
- C. For two (2) motors 15 h.p. and up, size components per the following table for 240 volt 3 phase services. Soft Starters shall be provided for motors 20 h.p and up.

MOTOR H.P.	MOTOR AMPS	SERVICE MINIMUM MOTOR AMPS <u>x2.25 + 12.5</u>	MAIN BREAKER <u>Item 1</u>	MOTOR CIRCUIT BREAKER <u>Item 6</u>	MOTOR STARTER <u>Item 8/ Item 41</u>	SERVICE WIRES AND CONDUIT	MOTOR WIRES AND CONDUIT (BETWEEN C.P. AND J-BOX)
15	42	107	150	100	NEMA-2	3-#1/0, 1-#4, 2" C	3-#6, 1-#8, 1 1/2" C
20	54	134	175	100	ATS22D75S6U	3-#2/0, 1-#4, 2" C	3-#4, 1-#8, 1 1/2" C
25	68	165.5	200	100	ATS22D88S6U	3-#3/0, 1-#3, 2" C	3-#3, 1-#6, 1 1/2" C
30	80	192.5	250	125	ATS22C11S6U	3-250KCM, 1-#2, 3" C	3-#2, 1-#6, 1 1/2" C

NOTES ON 480 VOLT PANELS:

- A. The following components shall change:

ITEM	NAME	DESCRIPTION	MANUFACTURER	TYPE
3	Generator Receptacle	4 wire 200 amp	Russellstoll	JRS2034HR
4	TVSS/SPD	277/480v, 3 phase, 4 wire	ASCO	430277YP10ACSJ1
9	Phase Monitor	Plug-in 8 pin 480 volt, 3p	MPE	001-DVM-118
19	Transformer Breaker	2p-15 Amps, 25k AIC (Min.)	Square D	HGL 26015

- B. The 480 volt short circuit rating of panel shall equal or exceed system S.C. amps. Contractor shall confirm this value with the power company and order the panel accordingly. In addition, the minimum S.C. amp rating of the panel shall be as follows:

For 100 amp service                      18,000 amps  
For 200 to 250 amp service            42,000 amps

MOTOR H.P.	MOTOR AMPS	SERVICE MINIMUM MOTOR AMPS <u>x2.25 + 6.25</u>	MAIN BREAKER <u>Item 1</u>	MOTOR CIRCUIT BREAKER <u>Item 6</u>	MOTOR STARTER <u>Item 8/ Item 41</u>	SERVICE WIRES AND CONDUIT	MOTOR WIRES AND CONDUIT (BETWEEN C.P. AND J-BOX)
15	21	53.5	100	40	NEMA-2	3-#2, 1-#4, 2" C	3-#8, 1-#10, 1 1/2" C
20	27	67.0	100	50	ATS22D47S6U	3-#2, 1-#4, 2" C	3-#8, 1-#10, 1 1/2" C
25	34	82.8	100	70	ATS22D47S6U	3-#2, 1-#4, 2" C	3-#8, 1-#10, 1 1/2" C
30	40	96.3	125	80	ATS22D62S6U	3-#1, 1-#4, 2" C	3-#6, 1-#8, 1 1/2" C
40	52	123.3	150	100	ATS22D75S6U	3-#1/0, 1-#4, 2" C	3-#4, 1-#8, 1 1/2" C
50	65	152.5	200	100	ATS22D88S6U	3-#3/0, 1-#3, 2" C	3-#3, 1-#6, 1 1/2" C
60	77	179.5	225	150	ATS22C11S6U	3-#4/0, 1-#2, 2" C	3-#2, 1-#6, 1 1/2" C
75	96	222.3	250	200	ATS22C14S6U	3-250KCM, 1-#2, 3" C	3-#1/0, 1-#6, 1 1/2" C

PALM BEACH COUNTY CONSTRUCTION STANDARDS & DETAILS

REVISION/ISSUE DATE

01/2023\*

**CONTROL PANEL**  
**240V & 480V PANELS NOTES**

PAGE NO.

67S

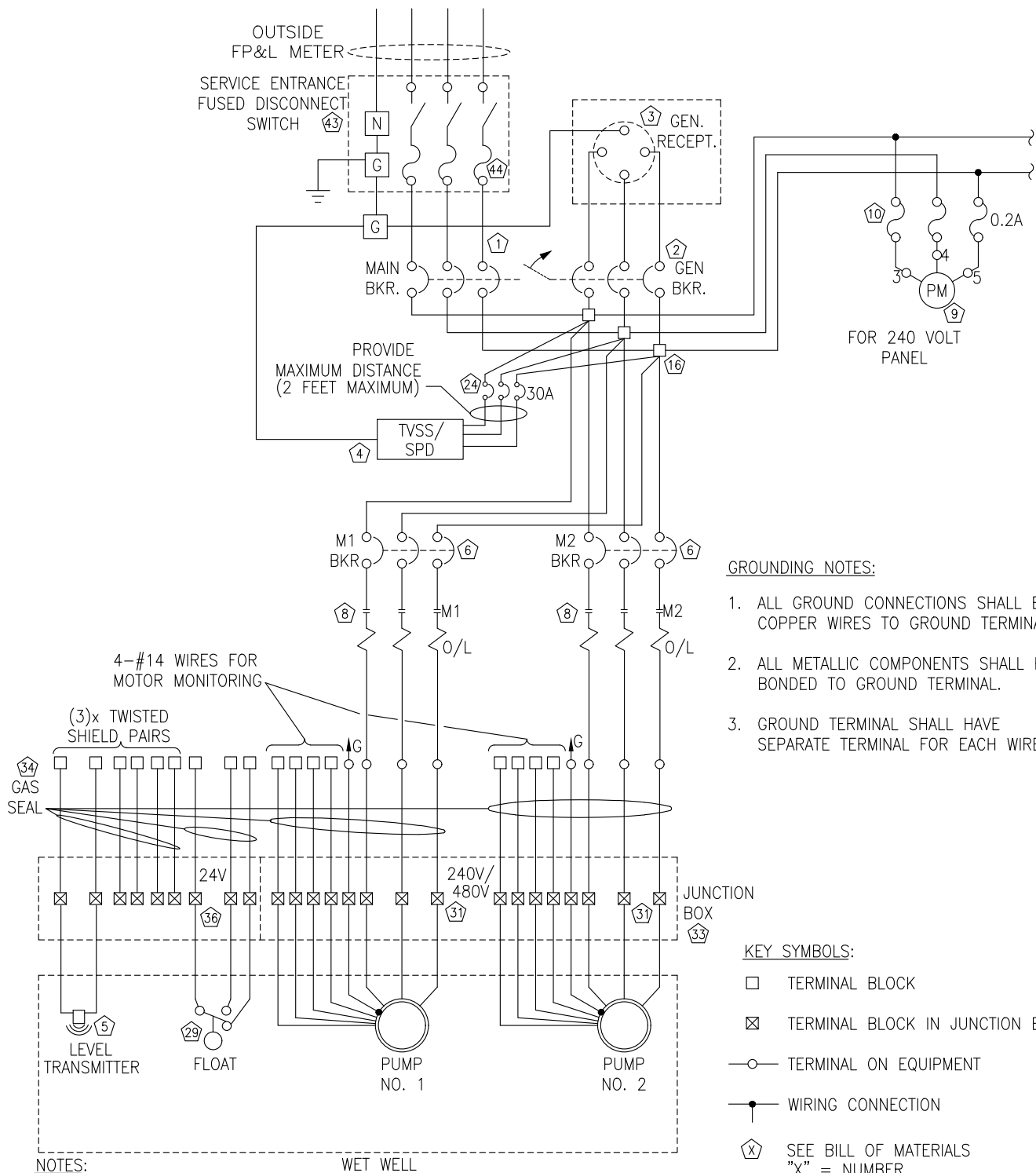

**GROUNDING NOTES:**

1. ALL GROUND CONNECTIONS SHALL BE COPPER WIRES TO GROUND TERMINAL.
2. ALL METALLIC COMPONENTS SHALL BE BONDED TO GROUND TERMINAL.
3. GROUND TERMINAL SHALL HAVE SEPARATE TERMINAL FOR EACH WIRE.

**KEY SYMBOLS:**

- TERMINAL BLOCK
- ⊗ TERMINAL BLOCK IN JUNCTION BOX
- TERMINAL ON EQUIPMENT
- WIRING CONNECTION
- ⓧ SEE BILL OF MATERIALS "X" = NUMBER

**NOTES:**

1. ALL COMPONENTS ARE IN PANEL UNLESS INDICATED OTHERWISE.
2. PROVIDE 4 WIRES FOR PUMP TEMPERATURE AND MOISTURE. COORDINATE WITH PUMP SUPPLIER.
3. CONTROL TRANSFORMER SHALL BE NEMA 3R, 316 PAINTED STAINLESS STEEL, MOUNTED OUTSIDE AND GROUNDED.

PALM BEACH COUNTY CONSTRUCTION STANDARDS & DETAILS

REVISION/ISSUE DATE  
01/2023\*

LIFT STATION  
ELECTRICAL SCHEMATIC (SHT 1 OF 3)

PAGE NO.  
68S

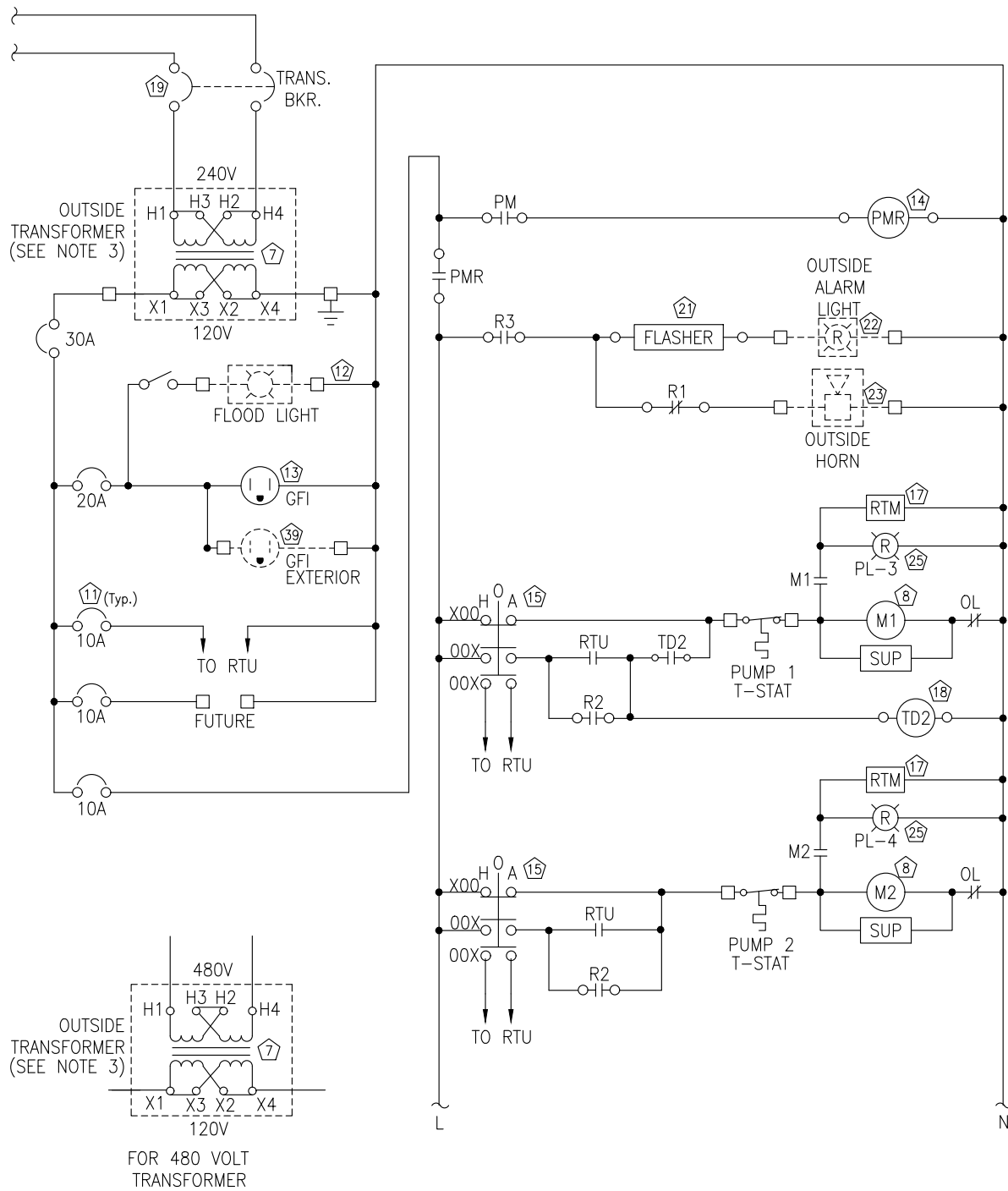

PALM BEACH COUNTY CONSTRUCTION STANDARDS & DETAILS

REVISION/ISSUE DATE

01/2023\*

LIFT STATION  
ELECTRICAL SCHEMATIC (SHT 2 OF 3)

PAGE NO.

69S

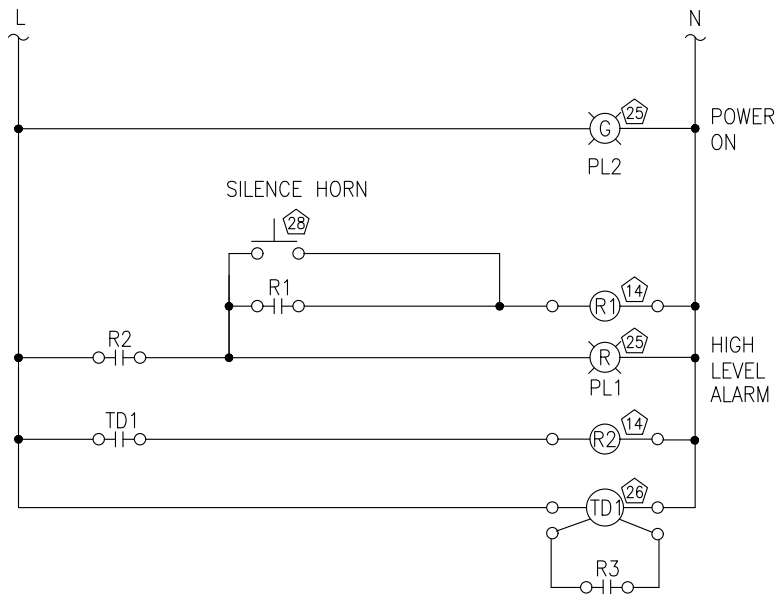

NOTE:

1. ALL COMPONENTS ARE IN PANEL UNLESS INDICATED OTHERWISE.

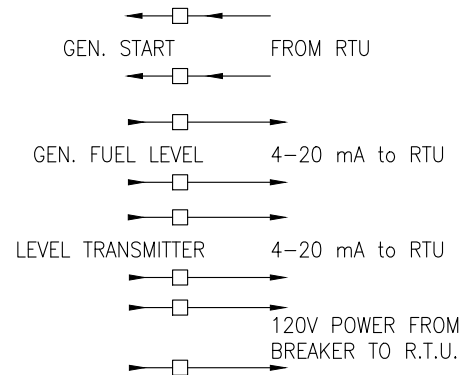
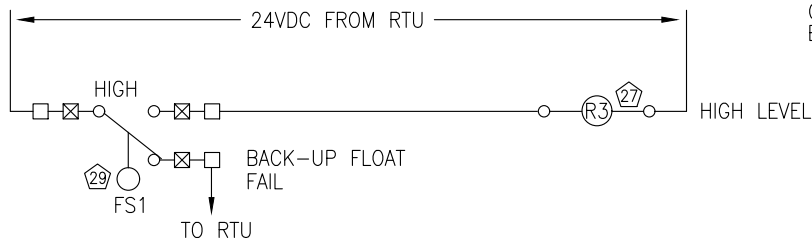
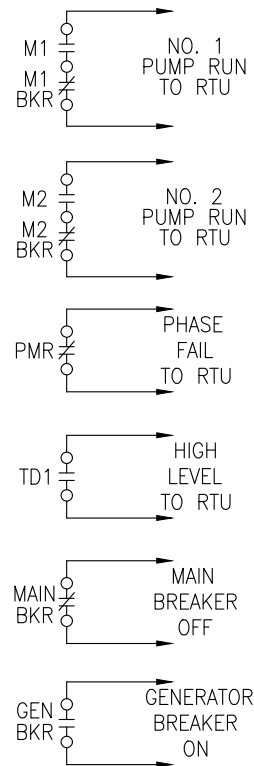

PALM BEACH COUNTY CONSTRUCTION STANDARDS & DETAILS

REVISION/ISSUE DATE

01/2023\*

LIFT STATION  
ELECTRICAL SCHEMATIC (SHT 3 OF 3)

PAGE NO.

70S

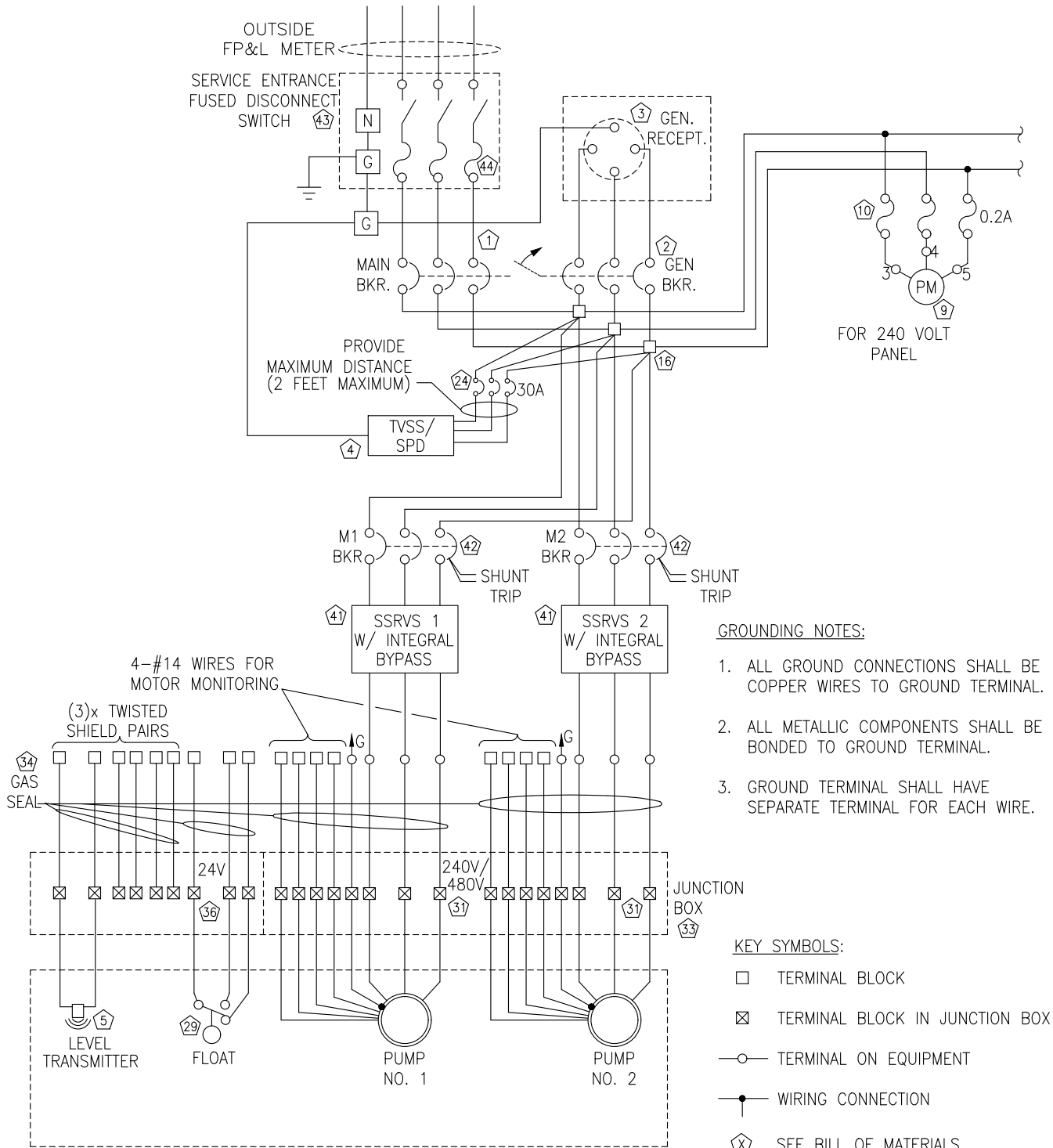

- GROUNDING NOTES:**
1. ALL GROUND CONNECTIONS SHALL BE COPPER WIRES TO GROUND TERMINAL.
  2. ALL METALLIC COMPONENTS SHALL BE BONDED TO GROUND TERMINAL.
  3. GROUND TERMINAL SHALL HAVE SEPARATE TERMINAL FOR EACH WIRE.

- KEY SYMBOLS:**
- TERMINAL BLOCK
  - ⊗ TERMINAL BLOCK IN JUNCTION BOX
  - TERMINAL ON EQUIPMENT
  - WIRING CONNECTION
  - ⓧ SEE BILL OF MATERIALS "X" = NUMBER

- NOTES:**
1. ALL COMPONENTS ARE IN PANEL UNLESS INDICATED OTHERWISE.
  2. PROVIDE 4 WIRES FOR PUMP TEMPERATURE AND MOISTURE. COORDINATE WITH PUMP SUPPLIER.
  3. CONTROL TRANSFORMER SHALL BE NEMA 3R, 316 PAINTED STAINLESS STEEL, MOUNTED OUTSIDE AND GROUNDED.

PALM BEACH COUNTY CONSTRUCTION STANDARDS & DETAILS

REVISION/ISSUE DATE  
**01/2023\***

**LIFT STATION ELECTRICAL SCHEMATIC  
 WITH SOFT STARTERS (SHT 1 OF 3)**

PAGE NO.  
**71S**

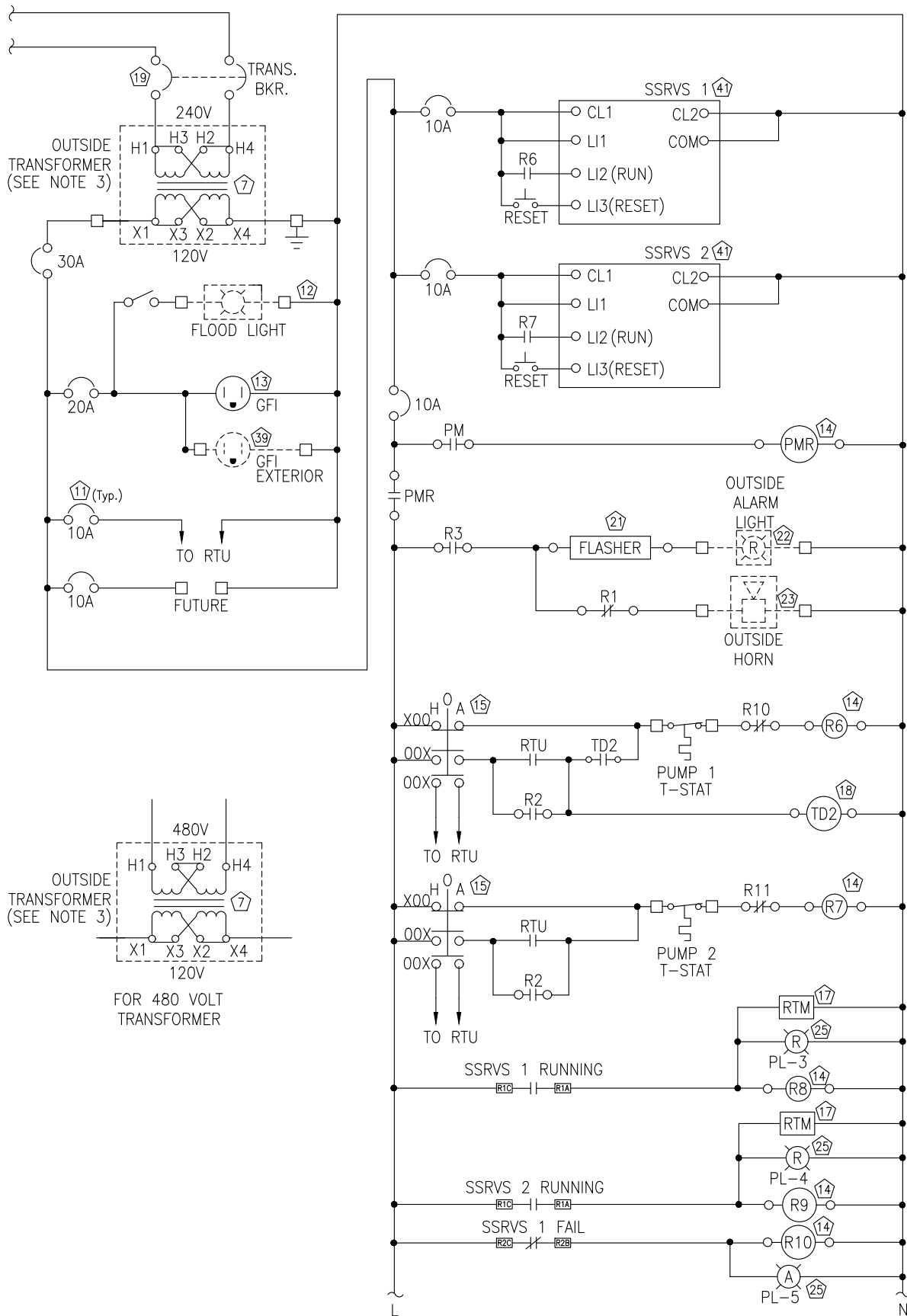

PALM BEACH COUNTY CONSTRUCTION STANDARDS & DETAILS

REVISION/ISSUE DATE

01/2023\*

LIFT STATION ELECTRICAL SCHEMATIC  
WITH SOFT STARTERS (SHT 2 OF 3)

PAGE NO.

72S



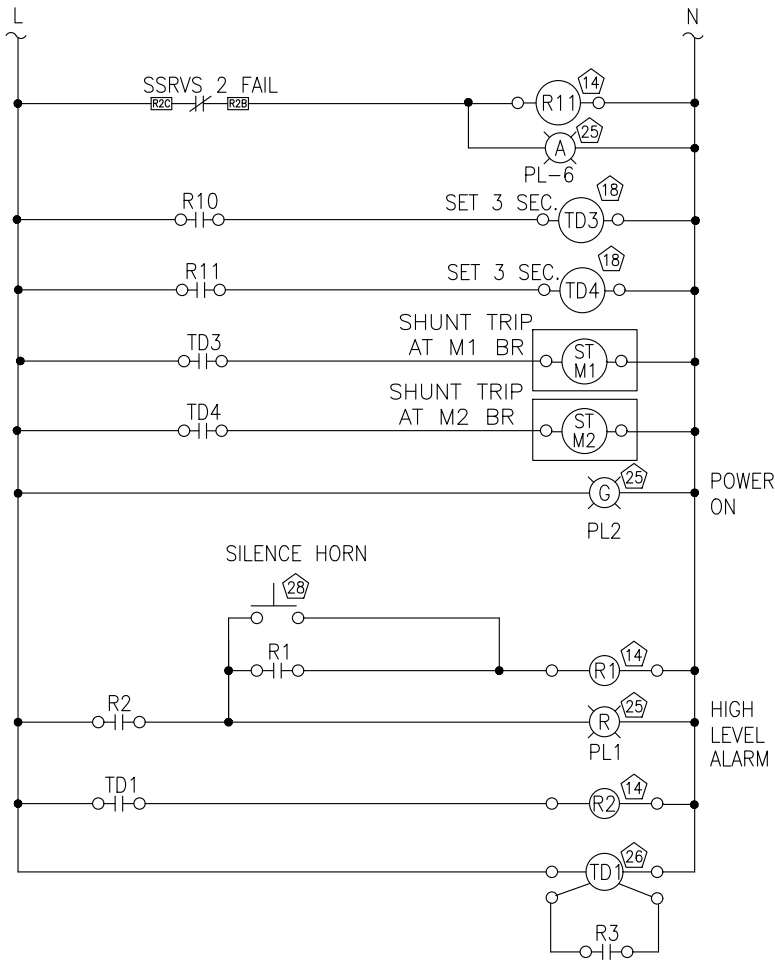

**NOTE:**  
 1. ALL COMPONENTS ARE IN PANEL UNLESS INDICATED OTHERWISE.

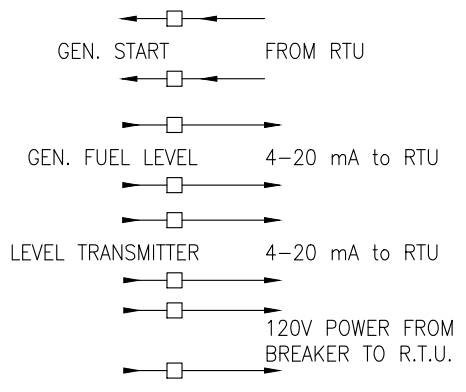
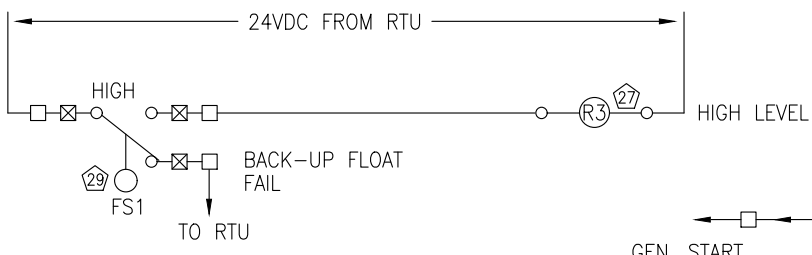
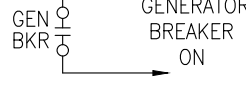
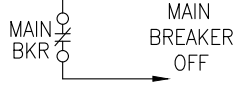
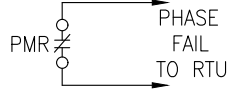

PALM BEACH COUNTY CONSTRUCTION STANDARDS & DETAILS

REVISION/ISSUE DATE  
 01/2023\*

LIFT STATION ELECTRICAL SCHEMATIC  
 WITH SOFT STARTERS (SHT 3 OF 3)

PAGE NO.  
 73S

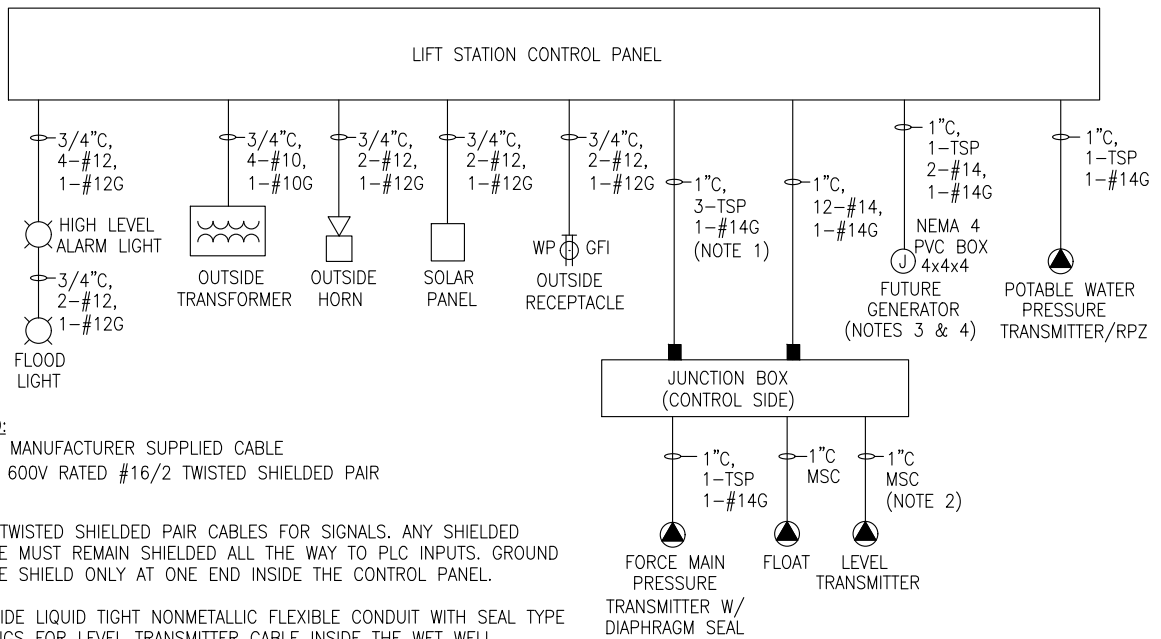

**LEGEND:**

MSC = MANUFACTURER SUPPLIED CABLE  
 TSP = 600V RATED #16/2 TWISTED SHIELDED PAIR

**NOTES:**

1. USE TWISTED SHIELDED PAIR CABLES FOR SIGNALS. ANY SHIELDED CABLE MUST REMAIN SHIELDED ALL THE WAY TO PLC INPUTS. GROUND CABLE SHIELD ONLY AT ONE END INSIDE THE CONTROL PANEL.
2. PROVIDE LIQUID TIGHT NONMETALLIC FLEXIBLE CONDUIT WITH SEAL TYPE FITTINGS FOR LEVEL TRANSMITTER CABLE INSIDE THE WET WELL.
3. COORDINATE WITH THE COUNTY FOR THE LOCATION OF FUTURE SKID MOUNTED GENERATOR INSIDE THE LIFT STATION FENCE.
4. INSTALL GENERATOR JUNCTION BOX 24" ABOVE FLOOR WITH 316 S.S. UNISTRUT SUPPORT AND 316 S.S. MOUNTING HARDWARE. BOX SHALL NOT IMPOSE THE TRIPPING HAZARD.

**LIFT STATION CONTROL PANEL RISER**

NOT TO SCALE

TB-1

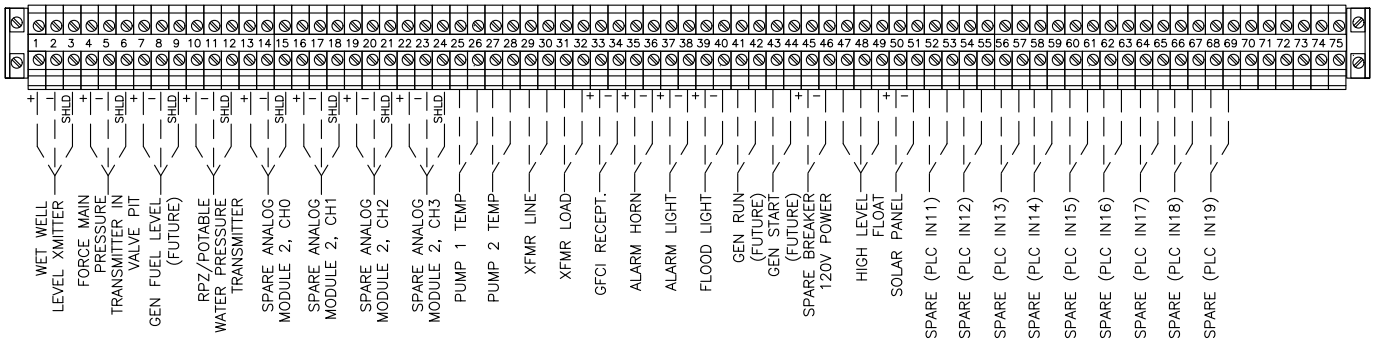

**WIRE TERMINAL TB-1**

NOT TO SCALE

REVISION/ISSUE DATE

01/2023\*

LIFT STATION CONTROL PANEL  
 ELECTRICAL RISER

PAGE NO.

74S

# 1. REMOTE TELEMETRY UNITS AND APPURTENANCES (R.T.U.)

A. The Remote Telemetry Units shall be microprocessor based, user programmable, Programmable Logic Controllers (PLC's) which shall serve as an interface to accumulate, process, transmit and receive discrete and analog status and control messages between the RTU base stations and the remote RTU sites located within a ten mile radius of the base station.

B. Each RTU shall be PLC based, with sufficient battery backed RAM, or EEPROM non-volatile backup memories to provide all discrete and analog status, monitoring and control functions and shall be designed to operate in an outdoor industrial environment.

C. The programmable controller shall be designed to operate in an industrial environment. The PLC shall be capable of operation in an ambient temperature range of 0°-60°C and a relative humidity of 5-95 percent, non-condensing. The PLC shall be capable of operation on supply voltages of 24VDC.

D. All components of the PLC system shall be of the same manufacturer who is regularly engaged in the manufacture of programmable controllers. The manufacturer shall have fully tested units similar to that being furnished in an industrial environment with associated electrical noise. The processing unit shall perform the operations functionally described herein based on the program stored in memory and the status of the inputs and outputs.

E. The processor and its associated memory shall be enclosed in a modular sheet metal enclosure. Memory shall consist of battery-backed RAM, which shall retain the control program in the event of AC power loss. Memory shall be not less than 8K user logic for any PLC and shall be adequate for all control functions specified. A minimum of 1920 on-board registers shall be addressable.

F. The relay logic instructions of the programmable controller shall include normally open; normally closed; transitional positive and negative contacts; timers in .01, .1, and 1.0- second resolution; and up/down counters. Register and table instructions shall include block moves, table to register, register to table, FIFO, table search, and table to table. Register matrix operations shall include bit sense, bit set/clear, and, or, exclusive or, bit rotate, and complement.

G. LED-type indicating lights shall be provided as follows: READY, RUN.

H. Programmable controllers and accessory equipment shall be Allen Bradley MicroLogix 1400, with memory module and two analog extension modules.

I. All RTUs shall be powered with 115 VAC through a power supply capable of float charging sealed Gel-cell batteries and shall include an AC power monitor with alarm output to the RTU on loss of AC power. Power supply shall be of sufficient capacity to provide all required DC power to all RTU equipment, discrete and analog input/output circuitry, under full load, communications interface equipment, radios and other radio interface/conditioning equipment and appurtenances as required. The primary power supply for radio, PLC and battery backup shall be 100 Watt, 24VDC Allen Bradley 1606-XLP100E. The batteries shall be lead acid sealed, 12 volt, 18 ampere-hour, model Power Sonic PS-12180. Two 12 volt batteries shall connected in series to get 24VDC battery backup. The Radio shall be powered through a relay contact and the PLC shall be able to power up or power down the radio as necessary.

As second power source, provide a Solar Panel with all necessary components including a solar controller. Solar panel shall be mounted on the antenna pole with stainless steel U-bolts. The solar panel Installation shall meet 150MPH wind loading requirements. Solar panel shall be 55 watt, 24 volt panel Solartech SPM055P-WP-F with pole mounting kit Sunwize 007954. The solar controller shall be Morningstar Sun saver SS-10L-24V. See wiring schematics for general information.

J. Provide one spare PLC and one spare radio for every group of three lift stations or less.

K. All analog inputs shall be furnished with lightning surge protection devices. Sufficient I/O shall be provided for each RTU to accommodate future expansion.

1. Digital inputs shall be 24VDC from dry contacts.

2. All outputs shall be wired through interposing relays (item 27). All analog and digital inputs shall be wired to terminal strip.

3. Analog input circuits shall be isolated, 12-bit resolution type. Analog inputs shall be coordinated with the receivers but shall generally be isolated 24V 4-20 mA inputs powered from the PLC. Analog input hardware shall be provided as specified for all types of analog inputs being transmitted to the PLC.

L. The RTU hardware shall be assembled to the back plate of the control panel or placed in a separate panel enclosure with a back plate. All components shall be mechanically secured and fully wired. A bonding wire #12 AWG with crimped end terminals is required between the back plate and control panel.

M. The following is a summary of approved remote telemetry equipment/materials and manufacturers.

## PALM BEACH COUNTY CONSTRUCTION STANDARDS & DETAILS

REVISION/ISSUE DATE

01/2023\*

REMOTE TELEMETRY UNIT  
SPECIFICATIONS (SHT 1 OF 5)

PAGE NO.

75S

<u>Equipment/Material</u>	<u>Manufacturer</u>
RF Lightning Surge Suppressor	A) PolyPhaser Corporation – IS-50NX-C2
Analog Surge Suppressor	A) EDCO Inc. – PC 642C-036 (Qty. 4)
Antenna Cable	A) Andrews Helix – LDF4-50A Low Loss Coaxial Cable
5 Watt Ethernet/Serial Radio to communicate w/ towers NTEL 1, NTEL 2, CTEL 1, STEL, WTEL	A) Microwave Data System – SD4-CES-NNSNN
10 Watt Ethernet/Serial Radio to communicate with tower CTEL 2	A) Microwave Data System – ORBIT MXNXL2XNNNNNNS1F5DUNN
Programmable Logic Controller Processor	A) Allen Bradley MicroLogix 1400/1766-L32BxB, with memory module 1766-MM1 & two analog extension modules 1762-IF4
120VAC to 24VDC Power Supply	A) Allen Bradley – 1606-XLP100E
Antenna – 450MHz – 475MHz	A) Sinclair – SY307-SF3SNM(ABK) – (Single array Yagi antenna) B) Sinclair – SY3072-SF3SNM(ABK) – (Dual array Yagi antenna)
Antenna – 216MHz – 235MHz	A) Type to be determined after new Tower CTEL 2 is established.
RF Coaxial Connector	A) Andrews – L4TNM-PSA or L4TNF-PSA
Vapor Phase Corrosion Inhibitor Capsules	A) Hoffman Model A-HC15E B) ZERUST Model VC-6-2

I/O List:

Pump No. 1 Run	digital input I/0
Pump No. 2 Run	digital input I/1
Pump No. 1 HOA	digital input I/2
Pump No. 2 HOA	digital input I/3
Generator Run (future)	digital input I/4
Back-up Float Fail	digital input I/5
Power Fail	digital input I/6
High Level Alarm	digital input I/7
Phase Monitor Alarm	digital input I/8
Main Breaker OFF	digital input I/9
Generator Breaker ON	digital input I/10
Pump No. 1 Start	digital output O/0
Pump No. 2 Start	digital output O/1
Portable Generator Start (future)	digital output O/2
Radio Power Control	digital output O/3
Lift Station Level	analog Input IV1 (extension module 1)
Gen. Fuel Level or water pressure (future)	analog Input IV2 (extension module 1)
Force Main Pressure	analog Input IV3 (extension module 1)
Potable water pressure	analog Input IV4 (extension module 1)

## 2. RTU COMMUNICATIONS INTERFACE

A. Bi-directional communications of status, commands and radio diagnostics between the RTUs and the RTU base station shall be provided by the RTU communications interface subsystem. The PLC MODBUS serial interface port shall serve as the RTU communications interface. The data transmission rate shall be set to operate at 9600 Baud (synchronous) in RTU mode.

B. The RTU communications interface shall control the modem during the polling sequence. It shall be possible to assign a base address to each RTU through the data interface. The addressing scheme shall allow a minimum of 247 RTUs for each data link. The communications protocol shall be master-slave MODBUS RTU.

## 3. RTU RADIO SECTION AND APPURTENANCES

A. The radio to communicate with any towers except CTEL 2 shall consist of a Microwave Data Systems model SD4-CES-NNSNN 5-watt (continuous) digital FSK modulation type radio transceiver with integral RF modem, RS-232 synchronous serial interface and cable, private line coded squelch and carrier defeat timer to inhibit communications lockup. Radio transceiver shall include automatic frequency, control, loop-back and SMART diagnostics remote maintenance module to monitor; power out, RSSI, voltage level, internal temperature and forward/reflected power. Radio enclosure shall include RF shield. The interface cable from radio to RF surge suppressor shall be 36" long, RG142 cable with N. Male RF connectors. The radio to communicate with CTEL 2 shall be as shown in above equipment lists.

## PALM BEACH COUNTY CONSTRUCTION STANDARDS & DETAILS

REVISION/ISSUE DATE

01/2023\*

REMOTE TELEMETRY UNIT  
SPECIFICATIONS (SHT 2 OF 5)

PAGE NO.

76S

B. Remote terminal unit antenna to communicate with any towers except CTEL 2 shall be a heavy-duty, pole-mounted, grounded, 450 MHz – 470MHz Yagi, directional type furnished with a minimum of 30 feet of Andrews Heliax (LDF4-50A) low loss coaxial antenna cable or approved equal, line adapter, lightning protector and appurtenances. Antenna and accessories shall be an SY307-SF3SNM(ABK) as manufactured by Sinclair or approved equal. Dual array Yagi antennae Sinclair SY3072-SF3SNM(ABK) shall be required if the Remote Receive Signal Strength (RSSI) is less than 95 dbm. Minimum antenna height shall be 18 feet above grade. On new mast installations, fabricate the antenna from 21 feet length of schedule 40 galvanized steel continuous pipe (2 inch diameter) or approved equal. Paint lower 4 feet with asphaltum paint and cap the top of the pipe. RF lightning surge suppressor shall be IS-50NX-C2 by Polyphaser Corporation. Yagi antenna shall have a pig tail with N-Male connector. Coaxial antenna cable shall have an N-Female connector Andrew L4TNF-PSA on one end and an N-Male connector Andrew L4TNM-PSA connector on other end. The antenna connectors on the antenna mast shall be wrapped with rubber tape and heat shrink tubing. Heat shrink tubing shall be Alpha FIT-321-1inch. The antenna orientation toward the receiving communication tower shall be set using appropriate instruments. The antenna to communicate with CTEL 2 to be determined after the tower is established.

C. The complete communications subsystem including all interconnecting cables shall contain lightning, surge and transient protection. All antennae masts shall be grounded.

D. Radios shall be programmed by PBCWUD technicians for the frequency of the tower that the radio will be communicating with. See attached RTU Schedule for location of stations. Frequencies are as follows:

1. North Tower 1 (NTEL 1) – Remote transmit-465.1500 MHz – Receive-460.1500 MHz  
For stations located north of Lantana Rd., south of Roebuck Rd., and east of S.R. 7  
2956 Pinehurst Dr., Greenacres, FL (Coordinates: 26°38.017'N, 80°09.352'W)

2. North Tower 2 (NTEL 2) – Remote transmit-456.8625 MHz – Receive-451.8625 MHz  
For stations located north of Forest Hill Blvd., and east of S.R. 7  
8130 North Jog Rd., West Palm Beach, FL (Coordinates: 26°47'52.50"N, 80°08'12.97"W)

3. Central Tower 1 (CTEL 1) – Remote transmit-465.750 MHz – Receive-460.750 MHz  
For stations located south of Lantana Rd. and North of Clint Moore Rd.  
12751 Hagen Ranch Rd., Delray Beach, FL (Coordinates: 26°29.260'N, 80°10.018'W)

4. Central Tower 2 (CTEL 2) – Transmit and Receive frequencies to be determined after the new CTEL 2 is built. For stations located south of Lantana Rd. and North of Clint Moore Rd.  
(Coordinates: TBD)

5. South Tower (STEL) – Remote transmit-465.075 MHz – Receive-460.075 MHz  
For stations located south of Clint Moore Rd.  
22438 S.W. 7th Street, Boca Raton, FL (Coordinates: 26°20.586'N, 80°11.840'W)

6. West Tower (WTEL) – Remote transmit-465.525 MHz – Receive-460.525 MHz  
For stations located north of S.R. 80 and west of S.R. 7; plus all stations located north of Roebuck Rd.  
20 S.R. 880, Loxahatchee, FL (Coordinates: 26°41.05'N, 80°23.37'W)

#### 4. RTU ELECTRICAL TRANSIENT PROTECTION

A. All electrical and electronic elements shall be protected against damage due to electrical transient induced in interconnecting lines from lightning discharges and nearby electrical systems.

B. Manufacturer's Requirements: All surge suppressor devices shall be manufactured by a company that has been engaged in the design, development, and manufacture of such devices for at least 5 years.

C. Suppressor Locations: As a minimum, provide surge suppressors at the following locations:

1. At any connections between field mounted instrument and electronic equipment.
2. At the field, panel, or assembly connections of all analog signal circuits that have any portion of the circuit extending outside of a protecting building.
3. Between the radio and external mounted antenna.

### PALM BEACH COUNTY CONSTRUCTION STANDARDS & DETAILS

REVISION/ISSUE DATE

01/2023\*

REMOTE TELEMETRY UNIT  
SPECIFICATIONS (SHT 3 OF 5)

PAGE NO.

77S

D. Surge Suppressors for Analog Signal Connections: Surge suppressors for analog signal circuits shall:

1. Have a dual-pair (four wire) module with the base.
2. Employ three-stage hybrid technology.
3. Be epoxy encapsulated with a nonflammable phenolic enclosure. Epoxy encapsulation shall be flame retardant.
4. Meet or exceed the following performance criteria:
  - a. Peak Source Current: 10,000 amps
  - b. Voltage Clamp Rating: 36 volts
  - c. Temperature Range: -40 degrees C to +85 degrees C
  - d. Maximum Operating Voltage: 30V dc
  - e. Operating Current: 4 to 20 mA dc
5. The suppressor shall be model 175D036S10KLPCNO by Square D or approved equal.

E. RF Surge Suppressors: RF surge suppressors shall:

1. Meet or exceed the following technical specifications:
  - a. Surge: 50kA IEC 1000-4-5 8/20ms Waveform 500 Joules
  - b. Turn on: 600 VDC +/-20%
  - c. Turn on time: 2.5ns for 2kV/ns
  - d. Frequency Range: 125MHz to 1GHz
  - e. VSWR: ≤1.1 to 1 over frequency range
  - f. Insertion Loss: ≤0.1 dB over frequency range
  - g. Temperature: -45°C to +85°C Storage/Operating +50°C
  - h. Unit Impedance: 50 Ohm
  - i. Mounting: Flange
2. The suppressor shall be of the type IS-50NX-C2 by PolyPhaser Inc. or approved equal.

## 5. RTU CORROSION PROTECTION

A. All indoor and outdoor cabinets, panels and consoles shall be fitted with vapor phase corrosion inhibitor capsules capable of protecting 5-cubic feet of space for one year; Hoffman Model A-HC15E, ZERUST Model VC-6-2 or approved equal. Capsules shall be labeled with the date of activation.

## 6. RTU FABRICATION

A. Cabinets and panels shall provide mounting for power supplies, control equipment, input/output subsystems, panel mounted equipment and appurtenances. Ample space shall be provided between equipment to facilitate servicing and cooling.

B. Terminal blocks shall be factory assembled on a miniature mounting channel and the channel bolted to the steel strap. Terminals shall be miniature screw type with integral fuse holder unless otherwise required. Terminal blocks shall provide access to screw terminals without disabling the fuses.

C. The terminals shall be marked vertically with a permanent, continuous marking strip from top to bottom. One side of each terminal strip shall be reserved exclusively for field incoming conductors. Common connections and jumpers required for internal wiring shall not be made on the field side of the terminal. Subject to the approval of the Owner, a vendor's pre-engineered and prefabricated wiring termination system will be acceptable.

D. Wiring shall comply with accepted standard instrumentation and electrical practices and codes. For each pair of parallel terminal blocks, the field wiring shall be between the blocks.

E. All wiring shall be bundled and run open or enclosed in vented plastic wire way, as required. All conductors run open shall be bundled and bound at regular intervals, not exceeding 12 inches, with nylon cable ties. Care shall be taken to separate electronic signal, discrete signal, and power wiring. A copper ground bus shall be installed the full length of each panel. Interior panel wiring and field wiring shall be tagged at all terminations with machine-printed plastic sleeves. The wire number shall be the ID number listed in the input/output schedules.

# PALM BEACH COUNTY CONSTRUCTION STANDARDS & DETAILS

REVISION/ISSUE DATE

01/2023\*

REMOTE TELEMETRY UNIT  
SPECIFICATIONS (SHT 4 OF 5)

PAGE NO.

78S

F. Wires shall be color coded as follows:

- Neutral – White
- Ground – Green
- Power – Red
- Signal – Black and White
- Control – Violet
- Special – Blue

G. Panels shall be provided with a main circuit breaker.

J. Stand alone RTU panel enclosures shall have the following specifications:

1. Enclosure shall be manufactured with 14 gauge Type 304, Powder Coated White, Stainless Steel Bodies and Doors, NEMA 4X.
2. Enclosure shall have seams continuously welded and ground smooth with no holes or knockouts.
3. Enclosure shall have a seamless foam-in-place gasket that assures a watertight and dust-tight seal. Glued-in place gaskets will not be accepted.
4. Enclosure shall have a rolled lip around three sides of door and all sides of enclosure to exclude liquids and contaminants.
5. All external hardware shall be stainless steel with piano hinge, three-point latch with roller fitting top and bottom and single handle with padlock fitting and stainless steel external parts.
6. Enclosure shall have an internal high impact thermoplastic data-pocket.
7. Enclosure shall have collar studs provided for mounting the Remote Telemetry Unit Panel. Collar studs will be placed identically in all enclosures and identical to existing Lift Station installations to facilitate moving of the Remote Telemetry Unit back-panel to another enclosure or lift station location as necessary.
8. Enclosure shall be lockable 30 inches in height by 24 inches in width and 12 inches in depth (30"H x 24"W x 12"D).
9. Enclosure shall be the product of a U.L. Listed manufacturer and made in accordance with the NEMA Type 4X standard.
10. Enclosure shall be by Hoffman Enclosures, Inc., or approved equal. The back-panel shall be stainless steel or aluminum.
11. Enclosure shall have a welded drip shield along the top front of the enclosure to guard against water intrusion. The drip shield shall extend 2-3-inches from top front edge of enclosure and be manufactured from stainless steel.
12. For RTUs to be incorporated into pump station electrical control panels: equipment shall be mounted on the back plate of the control panel.

PALM BEACH COUNTY CONSTRUCTION STANDARDS & DETAILS

REVISION/ISSUE DATE

01/2023\*

REMOTE TELEMETRY UNIT  
SPECIFICATIONS (SHT 5 OF 5)

PAGE NO.

79S

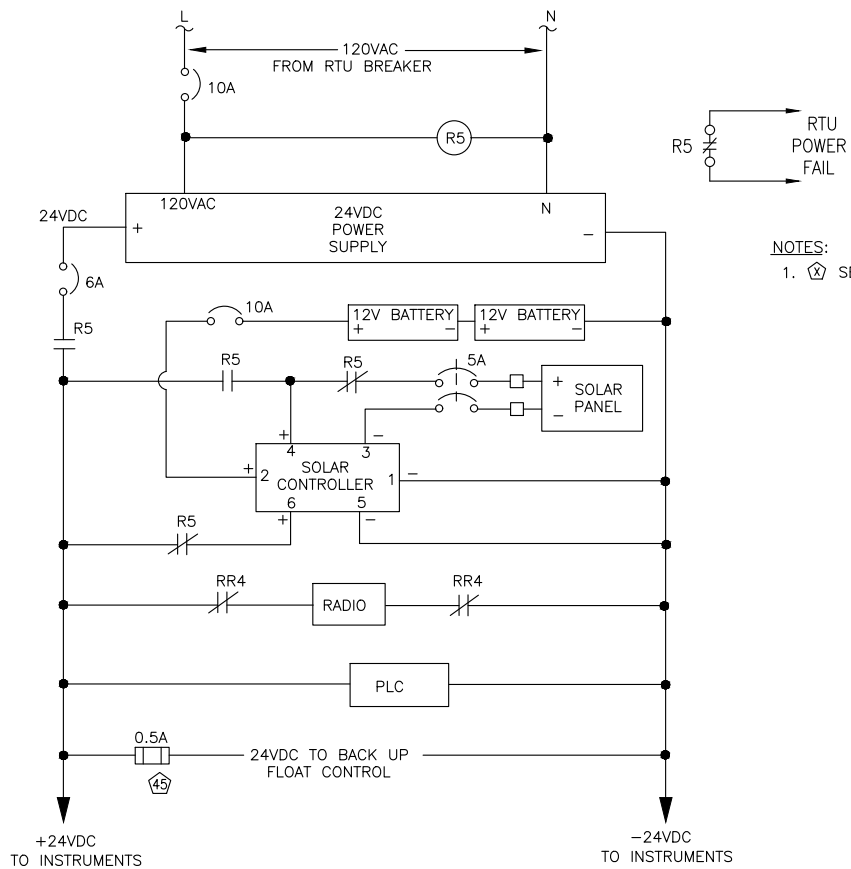

NOTES:  
1. (R5) SEE BILL OF MATERIALS.

RTU WIRING DIAGRAM

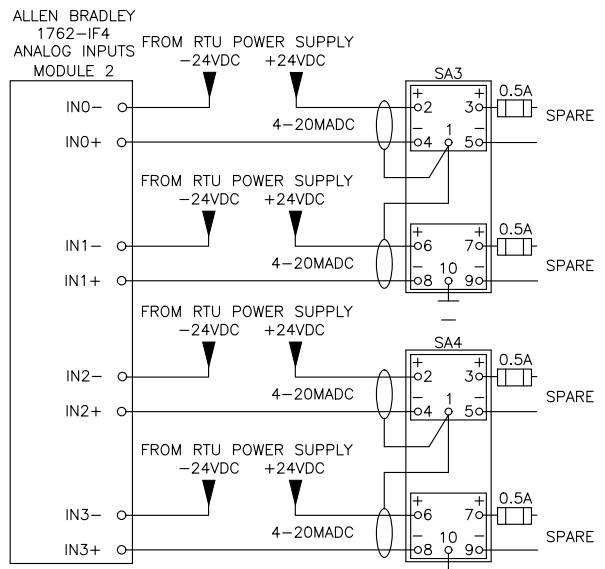
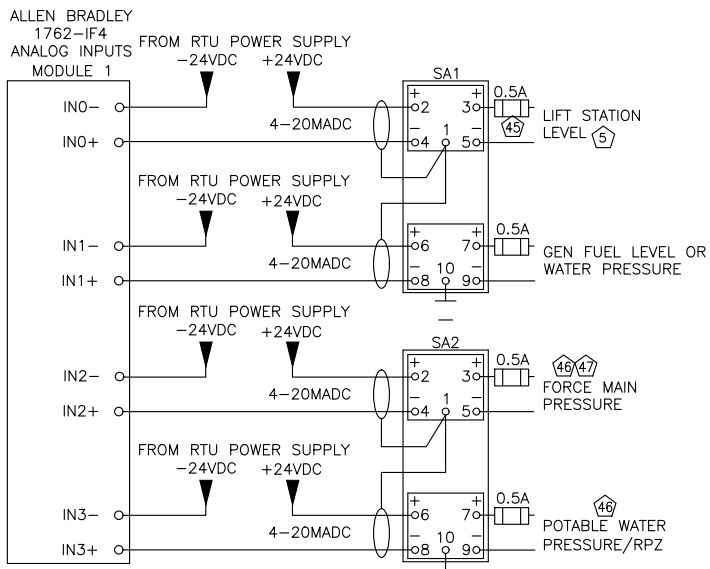

PLC ANALOG INPUTS WIRING DIAGRAM

PALM BEACH COUNTY CONSTRUCTION STANDARDS & DETAILS

REVISION/ISSUE DATE

01/2023\*

RTU WIRING AND  
PLC ANALOG INPUT WIRING DIAGRAM

PAGE NO.

80S



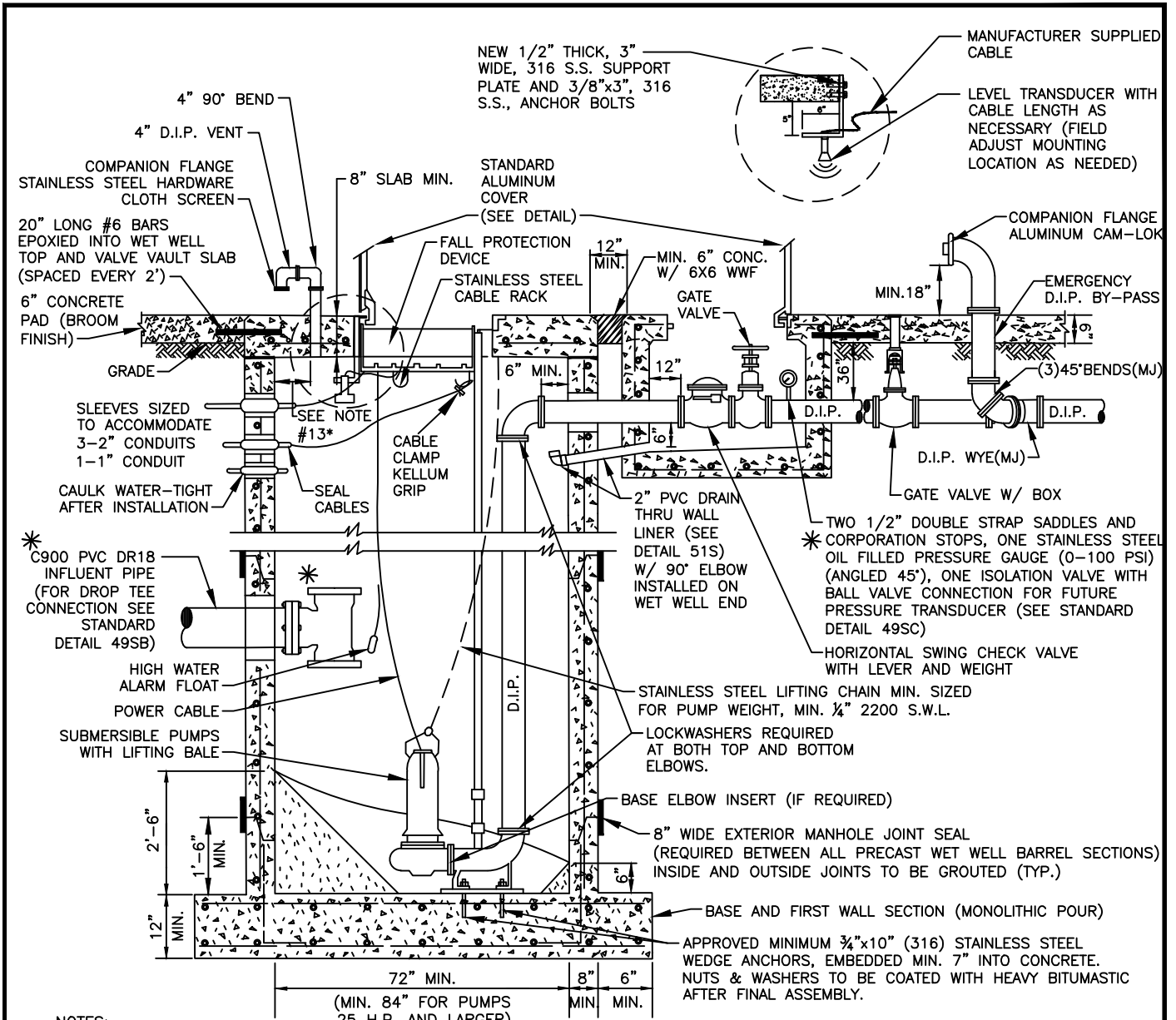

**NOTES:**

1. RAMNEK & NON-SHRINKING GROUT IN ACCORDANCE WITH STANDARD MANHOLE SPECIFICATIONS.
2. WET WELL PIPING AND VALVE VAULT PIPING TO RECEIVED 2 COATS OF KOPPERS BITUMASTIC 300M, 8-10 MILS EACH COAT, OR APPROVED EQUAL.
3. ALL STEEL IN WET WELL SHALL BE STAINLESS STEEL, INCLUDING GUIDE BARS, LIFTING CHAIN, CABLE SUPPORTS, CABLE HOLDER, AND GUIDE BAR BRACKET (TYPE 316).
4. TYPE II REINFORCED CONCRETE (#4 BARS THROUGHOUT), 4000 P.S.I. CALCAREOUS AGGREGATE REQUIRED (MIN. CaCO3 CONTENT: 65% IN LARGE AGGREGATE, 50% IN CONCRETE SCREENING).
5. SEE PLAN FOR CORRECT ORIENTATION OF PIPES, VENT, AND OTHER FIXTURES.
6. ALL HARDWARE INSIDE AND OUTSIDE OF WET WELL AND VALVE PIT SHALL BE STAINLESS STEEL (TYPE 316).
7. A. INSTALL 3/8" THICK STAINLESS STEEL PLATE THAT EXTENDS MIN. 3" AROUND PERIMETER OF BASE ELBOW.  
B. BASE ELBOW ANCHORS SHALL BE MIN. 3/4"x10" (316) STAINLESS STEEL, DOUBLE NUTTED, MIN. 2" THREAD LENGTH, TORQUED TO 150 FOOT POUNDS.
8. THREADED AREAS OF CORPORATION STOP SHALL BE SPIRAL WRAPPED WITH TWO WRAPS OF TEFLON TAPE.
9. INTERIOR OF A NEW WET WELL SHALL BE LINED WITH AN APPROVED SOLID THERMOPLASTIC CAST-IN LINER. INTERIOR OF A REHABILITATED WETWELL AND THE VALVE VAULT SHALL BE COATED WITH AN APPROVED CORROSION BARRIER SYSTEM. ANY PREVIOUSLY INSTALLED PIPING/EQUIPMENT SHALL BE PROTECTED FROM OVERSPRAY.
10. PAINT PUMP NUMBERS (1,2) ON UNDERSIDE OF WET WELL AND VALVE VAULT ALUMINUM COVERS (COLOR=RED, HEIGHT=12" MIN.)
11. A DROP PIPE MAY BE REQUIRED FOR HIGH FLOW LIFT STATIONS.
12. ALL PERTINENT NOTES FROM WET WELL DETAIL WITH CAST-IN LINER APPLY.
13. VENT PIPE TO BE LOCATED FROM THE WET WELL INTERIOR WALL 3 INCHES ON A 6 FOOT DIAMETER WET WELL AND 6 INCHES ON A 8 FOOT DIAMETER WET WELL.\*

PALM BEACH COUNTY CONSTRUCTION STANDARDS & DETAILS

REVISION/ISSUE DATE	TYPICAL LIFT STATION (SECTION)	PAGE NO.
01/2023*		81S

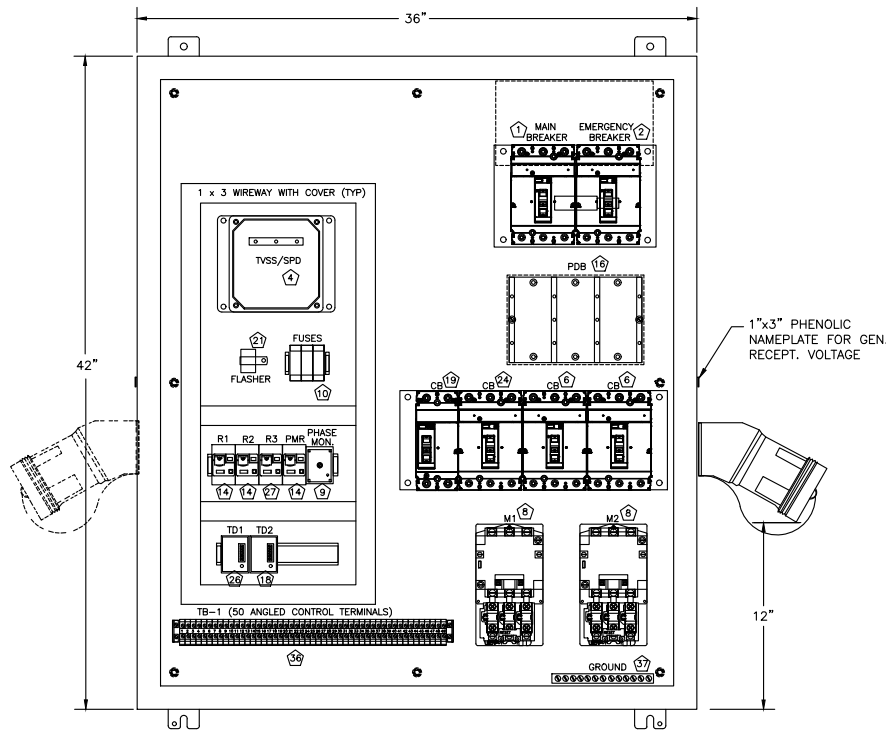

- NOTES:**
1. LOW PROFILE CONTROL PANEL DETAIL ONLY USED AT THE COUNTY'S DISCRETION FOR THE LIFT STATION SITES WHICH HAVE SITE CONSTRAINTS.
  2. SEE BILL OF MATERIALS.

- LOW PROFILE CONTROL PANEL SPECIFICATION:**
1. THE SPECIFICATIONS OF THE LOW PROFILE CONTROL PANEL ARE THE SAME AS THE STANDARD LIFT STATION PANEL SPECIFICATIONS EXCEPT THE SIZE. THE LOW PROFILE CONTROL PANEL BE 36"W x 42"H x 12"D.

**LOW PROFILE CONTROL PANEL INTERNAL LAYOUT FOR MOTORS 15 HP AND SMALLER**  
NOT TO SCALE

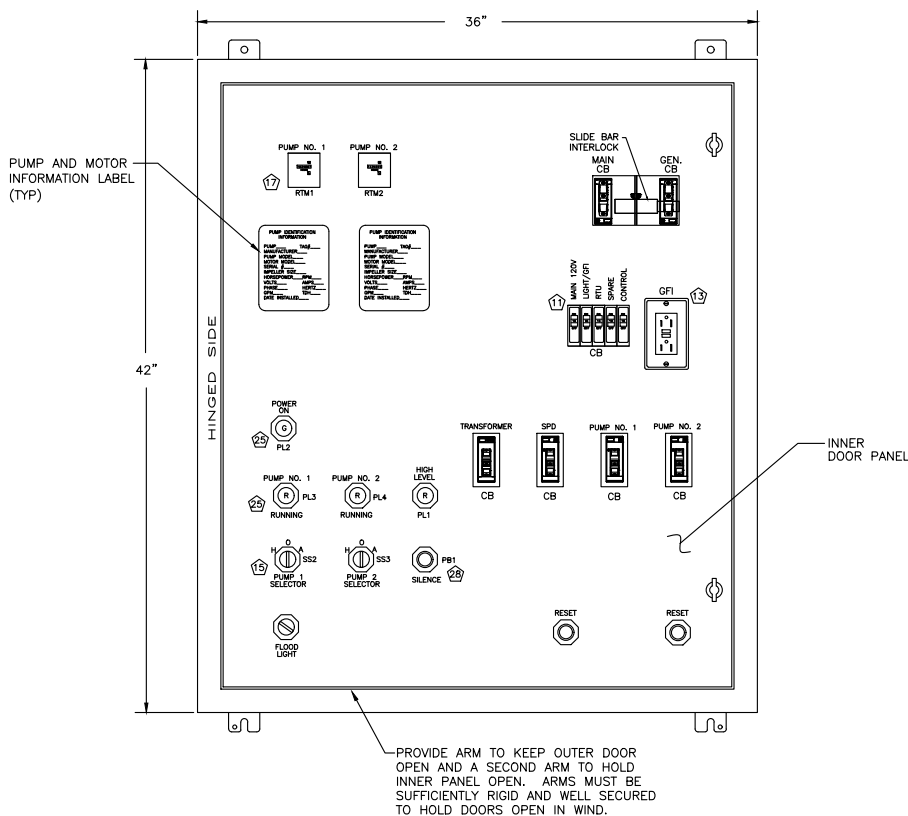

**LOW PROFILE CONTROL PANEL INNER DOOR LAYOUT FOR MOTORS 15HP AND SMALLER**  
NOT TO SCALE

PALM BEACH COUNTY CONSTRUCTION STANDARDS & DETAILS

REVISION/ISSUE DATE  
01/2023\*

LIFT STATION LOW PROFILE CONTROL PANEL LAYOUT  
FOR MOTORS 15HP AND SMALLER\*

PAGE NO.  
82S\*

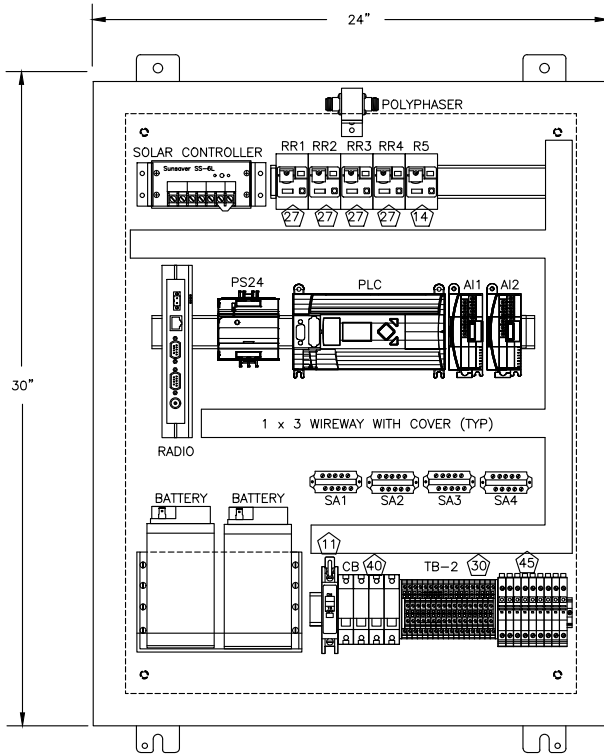

STANDALONE RTU PANEL LAYOUT  
NOT TO SCALE

- NOTES:
1. STANDALONE RTU SHALL BE PROVIDED WITH LOW PROFILE CONTROL PANEL ONLY.
  2. SEE STANDARD REMOTE TELEMETRY UNIT SPECIFICATIONS SHEET 1 TO SHEET 5.
  3. SEE BILL OF MATERIALS.

TB-2 (LOCATED IN STANDALONE RTU PANEL)

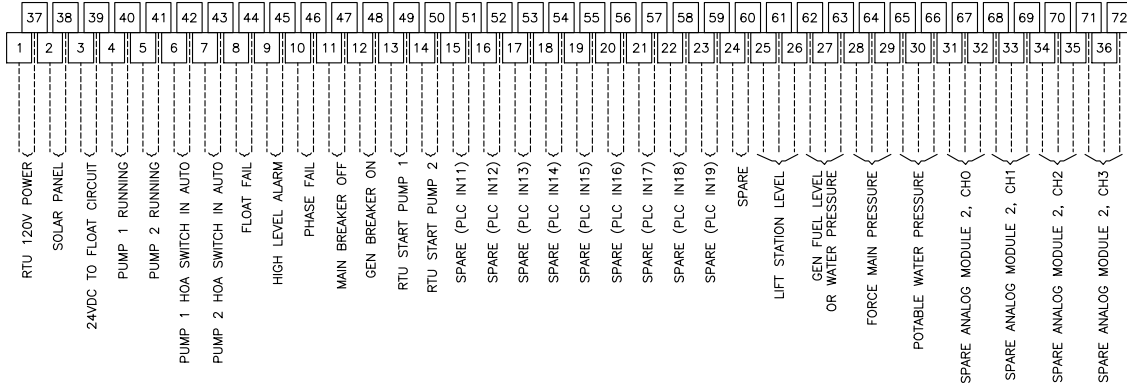

TB-1 (LOCATED IN LOW PROFILE CONTROL PANEL)

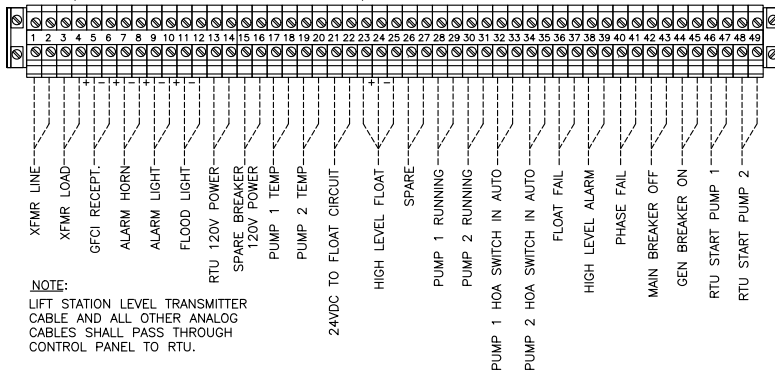

NOTE:  
LIFT STATION LEVEL TRANSMITTER CABLE AND ALL OTHER ANALOG CABLES SHALL PASS THROUGH CONTROL PANEL TO RTU.

TERMINAL BLOCKS LAYOUT  
NOT TO SCALE

PALM BEACH COUNTY CONSTRUCTION STANDARDS & DETAILS

REVISION/ISSUE DATE  
01/2023\*

LIFT STATION STANDALONE RTU PANEL LAYOUT  
TO BE USED WITH LOW PROFILE CONTROL PANEL\*

PAGE NO.  
83S\*

**NOTES:**

1. THE CONDUIT PROTECTING THE HELIAX COAXIAL ANTENNAE CABLE DOES NOT NEED A WEATHER HEAD AND MUST NOT ENTER THE PANEL.
2. AIR & WATER TIGHT FITTING IS REQUIRED FOR HELIAX CABLE/PANEL ENTRY.
3. ALL CONDUITS TO BE PLACED BELOW 6" COMPACTED LIMEROCK BASE.
4. ALL EXPOSED CONDUITS SHALL BE RIGID GALVANIZED STEEL (RGS) AND ALL UNDERGROUND CONDUITS SHALL BE SCHEDULE 80 PVC EXCEPT SERVICE CONDUIT FROM FPL WHICH SHALL BE RGS. TRANSITION FROM PVC TO RGS SHALL BE IN UNDERGROUND.
5. DIRECT BURIED GROUNDING CONDUCTOR SHALL BE BARE TINNED COPPER.
6. PROVIDE RAIN TIGHT HUB FOR ALL CONDUIT CONNECTIONS TO PANELS AND EQUIPMENT UNLESS INDICATED OTHERWISE.
7. ELECTRICAL PANEL SUPPORT STRUCTURE AND ANTENNA MAST HAVE BEEN DESIGNED IN ACCORDANCE WITH THE FLORIDA BUILDING CODE 2010 FOR THE FOLLOWING CRITERIA:
  - RISK CATEGORY IV
  - EXPOSURE CATEGORY "C"
  - WIND VELOCITY,  $V_{ult} = 181$  MPH
8. RTU AND CONTROL PANEL DOORS SHALL BE ARRANGED TO OPEN OUTWARD FROM THE MOTOR TERMINAL JUNCTION BOX.
9. MIRROR THE CONTROL PANEL LAYOUT TO HAVE THE GENERATOR RECEPTACLE ON THE DRIVEWAY SIDE.
10. JUNCTION BOX SHOULD BE IN LINE WITH THE WET WELL TO AVOID UNNECESSARY BENDS. JUNCTION BOX DOOR SHALL OPEN DOWNWARD.
11. ANY MODIFICATIONS TO EQUIPMENT LAYOUT SHALL BE SUBMITTED FOR APPROVAL PRIOR TO INSTALLATION.

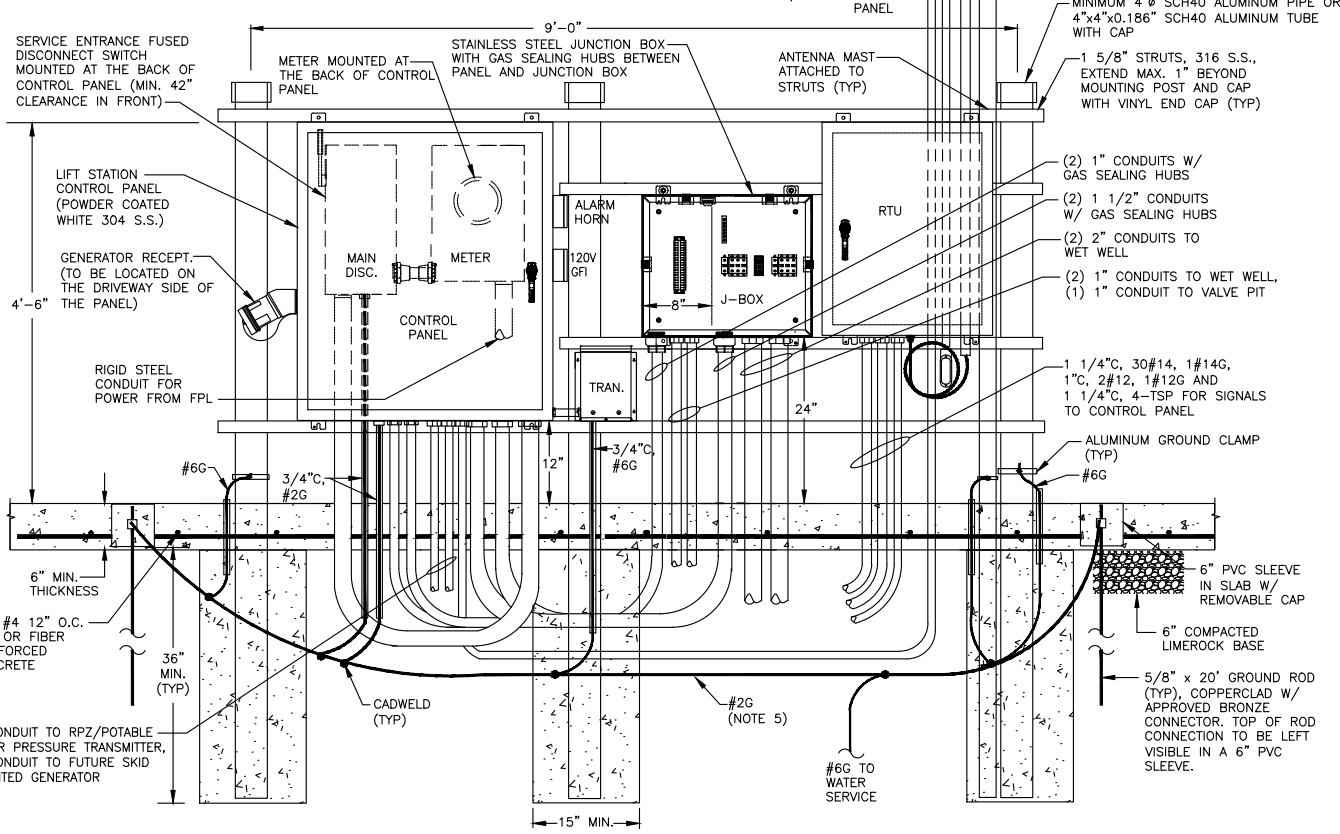
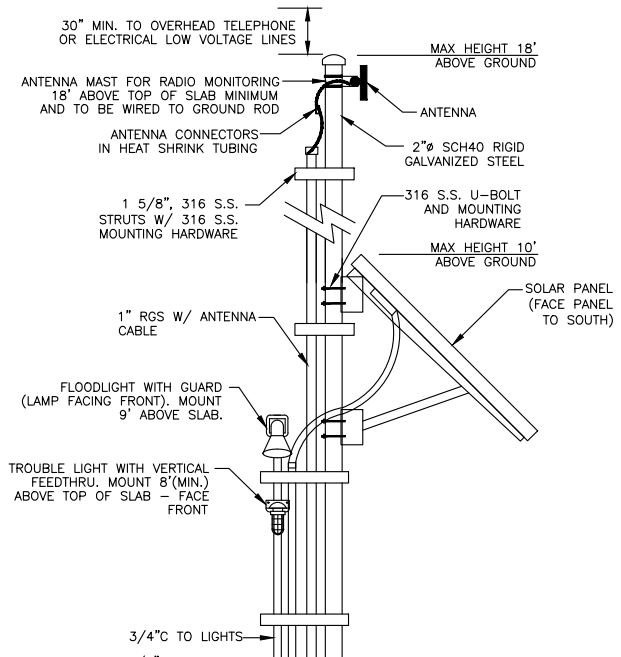

PALM BEACH COUNTY CONSTRUCTION STANDARDS & DETAILS

REVISION/ISSUE DATE  
 01/2023\*

LIFT STATION EQUIPMENT LAYOUT #1  
 WITH LOW PROFILE CONTROL PANEL\*

PAGE NO.  
 84S\*

**NOTES:**

1. THE CONDUIT PROTECTING THE HELIAX COAXIAL ANTENNAE CABLE DOES NOT NEED A WEATHER HEAD AND MUST NOT ENTER THE PANEL.
2. AIR & WATER TIGHT FITTING IS REQUIRED FOR HELIAX CABLE/PANEL ENTRY.
3. ALL CONDUITS TO BE PLACED BELOW 6" COMPACTED LIMEROCK BASE.
4. ALL EXPOSED CONDUITS SHALL BE RIGID GALVANIZED STEEL (RGS) AND ALL UNDERGROUND CONDUITS SHALL BE SCHEDULE 80 PVC EXCEPT SERVICE CONDUIT FROM FPL WHICH SHALL BE RGS. TRANSITION FROM PVC TO RGS SHALL BE IN UNDERGROUND.
5. DIRECT BURIED GROUNDING CONDUCTOR SHALL BE BARE TINNED COPPER.
6. PROVIDE RAIN TIGHT HUB FOR ALL CONDUIT CONNECTIONS TO PANELS AND EQUIPMENT UNLESS INDICATED OTHERWISE.
7. ELECTRICAL PANEL SUPPORT STRUCTURE AND ANTENNA MAST HAVE BEEN DESIGNED IN ACCORDANCE WITH THE FLORIDA BUILDING CODE 2010 FOR THE FOLLOWING CRITERIA:
  - RISK CATEGORY IV
  - EXPOSURE CATEGORY "C"
  - WIND VELOCITY,  $V_{ult} = 181$  MPH
8. RTU AND CONTROL PANEL DOORS SHALL BE ARRANGED TO OPEN OUTWARD FROM THE MOTOR TERMINAL JUNCTION BOX.
9. MIRROR THE CONTROL PANEL LAYOUT TO HAVE THE GENERATOR RECEPTACLE ON THE DRIVEWAY SIDE.
10. JUNCTION BOX SHOULD BE IN LINE WITH THE WET WELL TO AVOID UNNECESSARY BENDS. JUNCTION BOX DOOR SHALL OPEN DOWNWARD.
11. ANY MODIFICATIONS TO EQUIPMENT LAYOUT SHALL BE SUBMITTED FOR APPROVAL PRIOR TO INSTALLATION.

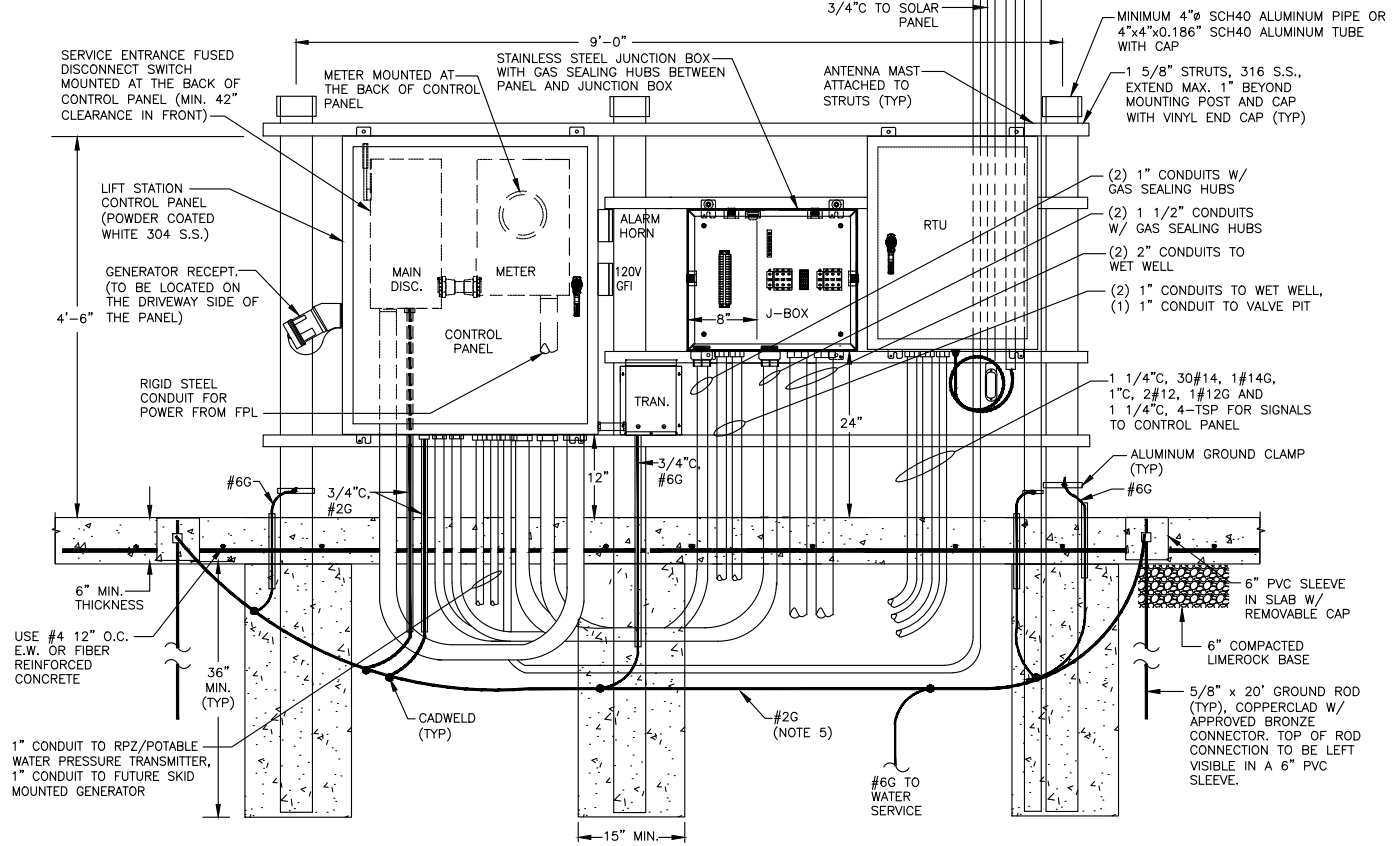
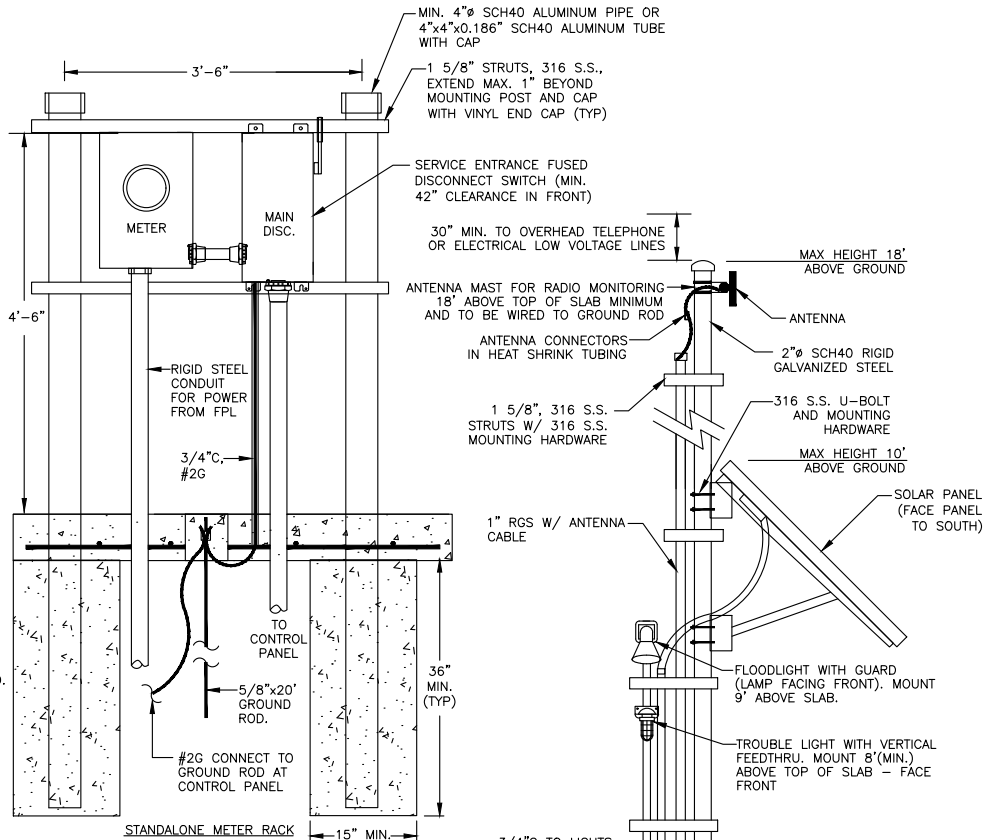

PALM BEACH COUNTY CONSTRUCTION STANDARDS & DETAILS

REVISION/ISSUE DATE  
01/2023\*

LIFT STATION EQUIPMENT LAYOUT #2  
WITH LOW PROFILE CONTROL PANEL\*

PAGE NO.  
85S\*

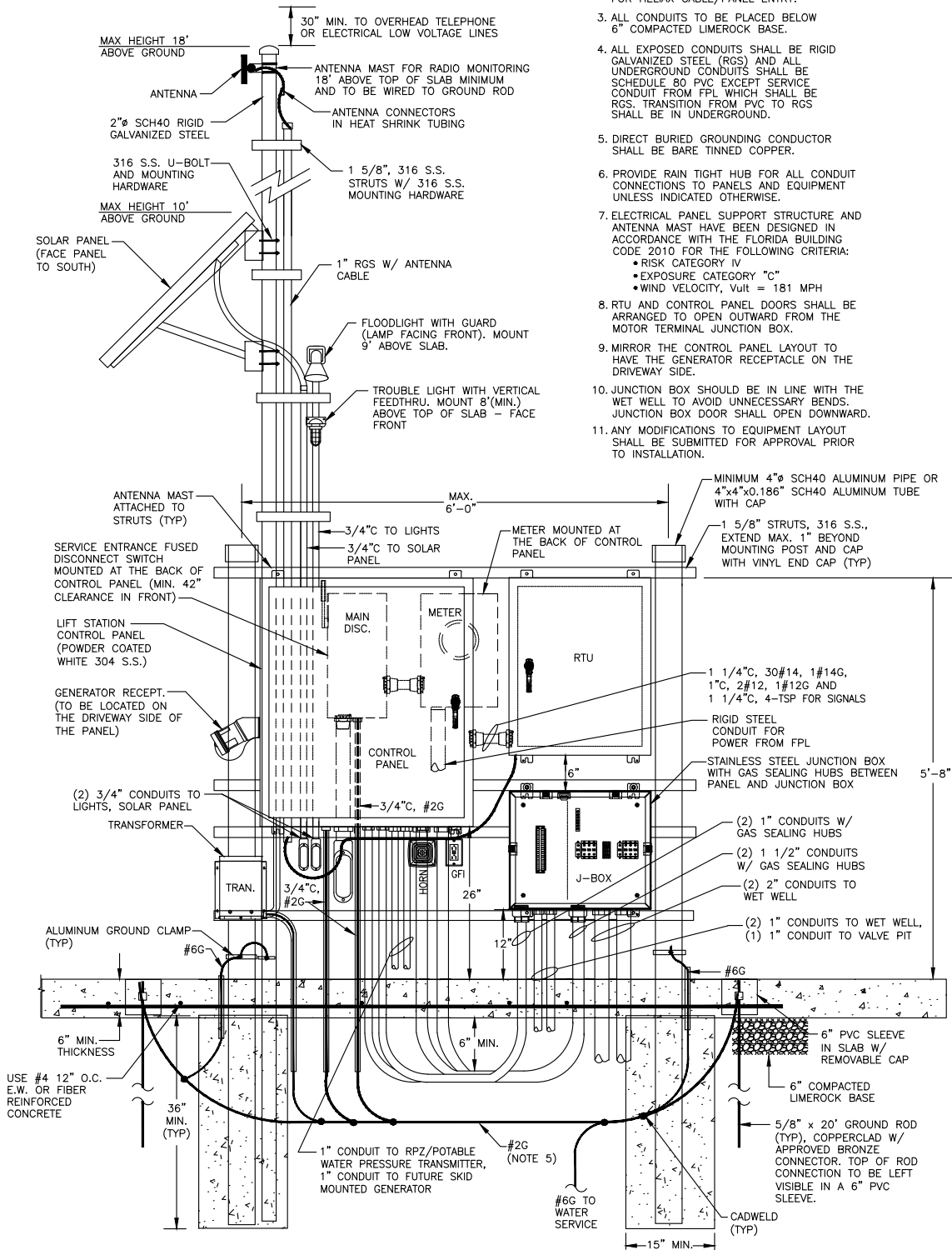

- NOTES:**
1. THE CONDUIT PROTECTING THE HELIAX COAXIAL ANTENNAE CABLE DOES NOT NEED A WEATHER HEAD AND MUST NOT ENTER THE PANEL.
  2. AIR & WATER TIGHT FITTING IS REQUIRED FOR HELIAX CABLE/PANEL ENTRY.
  3. ALL CONDUITS TO BE PLACED BELOW 6" COMPACTED LIMEROCK BASE.
  4. ALL EXPOSED CONDUITS SHALL BE RIGID GALVANIZED STEEL (RGS) AND ALL UNDERGROUND CONDUITS SHALL BE SCHEDULE 80 PVC EXCEPT SERVICE CONDUIT FROM FFL WHICH SHALL BE RGS. TRANSITION FROM PVC TO RGS SHALL BE IN UNDERGROUND.
  5. DIRECT BURIED GROUNDING CONDUCTOR SHALL BE BARE TINNED COPPER.
  6. PROVIDE RAIN TIGHT HUB FOR ALL CONDUIT CONNECTIONS TO PANELS AND EQUIPMENT UNLESS INDICATED OTHERWISE.
  7. ELECTRICAL PANEL SUPPORT STRUCTURE AND ANTENNA MAST HAVE BEEN DESIGNED IN ACCORDANCE WITH THE FLORIDA BUILDING CODE 2010 FOR THE FOLLOWING CRITERIA:
    - RISK CATEGORY IV
    - EXPOSURE CATEGORY "C"
    - WIND VELOCITY,  $V_{ult} = 181$  MPH
  8. RTU AND CONTROL PANEL DOORS SHALL BE ARRANGED TO OPEN OUTWARD FROM THE MOTOR TERMINAL JUNCTION BOX.
  9. MIRROR THE CONTROL PANEL LAYOUT TO HAVE THE GENERATOR RECEPTACLE ON THE DRIVEWAY SIDE.
  10. JUNCTION BOX SHOULD BE IN LINE WITH THE WET WELL TO AVOID UNNECESSARY BENDS. JUNCTION BOX DOOR SHALL OPEN DOWNWARD.
  11. ANY MODIFICATIONS TO EQUIPMENT LAYOUT SHALL BE SUBMITTED FOR APPROVAL PRIOR TO INSTALLATION.

PALM BEACH COUNTY CONSTRUCTION STANDARDS & DETAILS

REVISION/ISSUE DATE  
 01/2023\*

LIFT STATION EQUIPMENT LAYOUT #3  
 WITH LOW PROFILE CONTROL PANEL\*

PAGE NO.  
 86S\*

**NOTES:**

1. APPROVED PLUMBING PLAN MUST BE ON JOB SITE FOR INSPECTION, IF NOT, INSTALLATION WILL BE REJECTED.
2. PLUMBING SHALL CONFORM TO ALL PALM BEACH COUNTY AND OTHER APPLICABLE CODES.
3. **TEMPORARY CAP IN PLACE (NO SEWAGE). UPSTREAM OF THE VENT PIPE TO BE IN PLACE UNTIL WUD INSPECT AND INSTALL VALVE**
4. EXISTING SEPTIC TANK TO BE ABANDONED IN ACCORDANCE WITH LOCAL HEALTH DEPT. SPECIFICATIONS.
5. AIR INTAKE ASSEMBLY IS REQUIRED.
6. AIR VAC VALVE WILL BE INSTALLED BY UTILITY **AFTER** 4" AIR-INTAKE ASSEMBLY IS IN PLACE.
7. 6. SEWER CONNECTION FEES TO BE PAID PRIOR TO CONNECTION.
8. **TEMPORARY CAP IN PLACE UNTIL WUD INSPECT AND INSTALL VALVE.**
9. **CAP IS NOT TO BE REMOVED UNTIL WUD HAS INSTALLED VALVE**

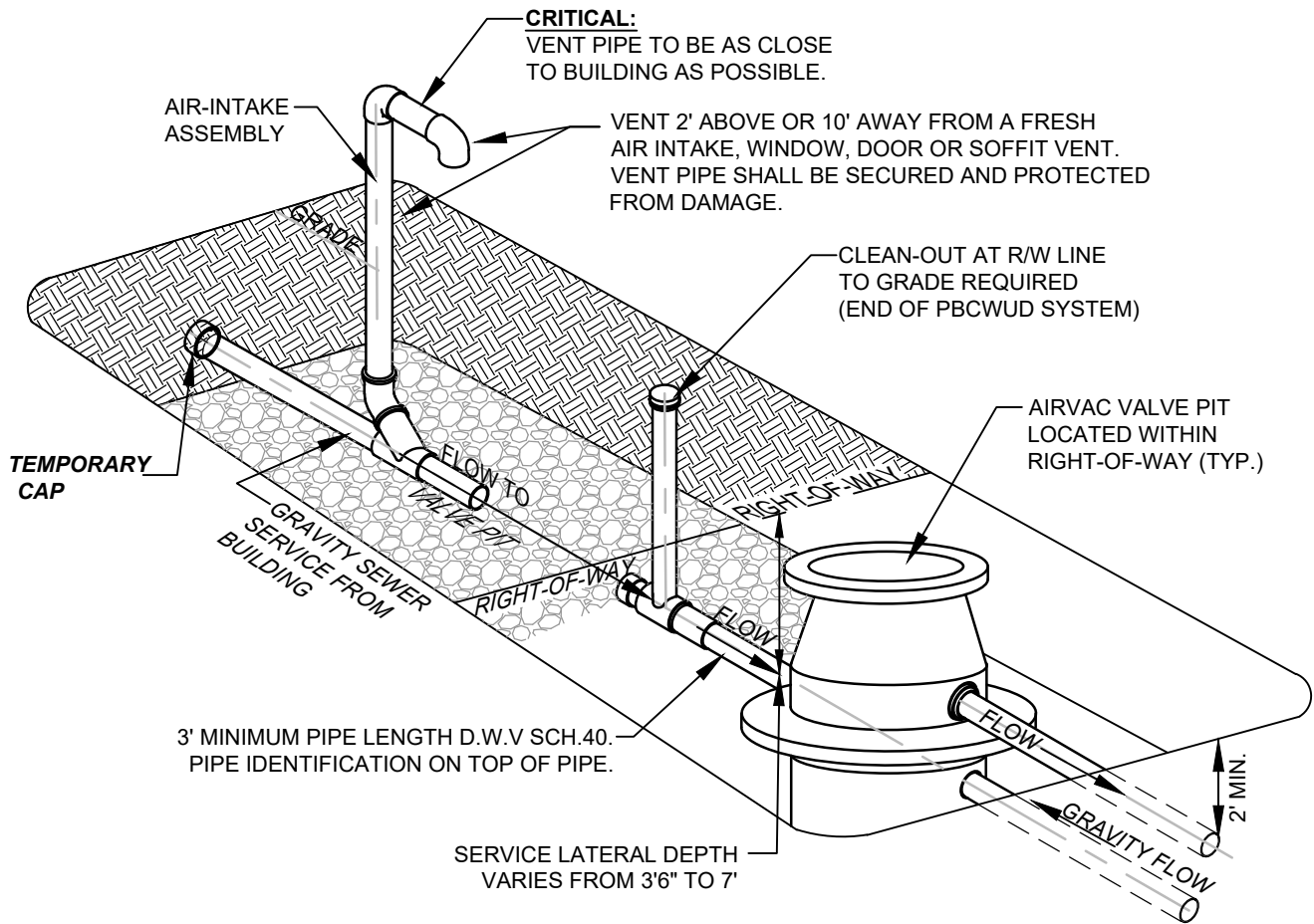
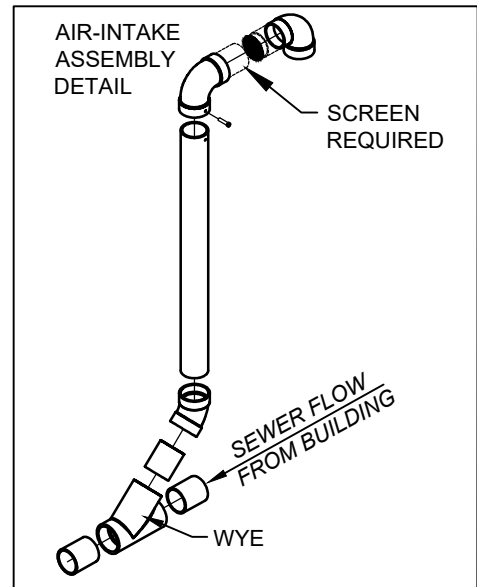

PALM BEACH COUNTY CONSTRUCTION STANDARDS & DETAILS

REVISION/ISSUE DATE

01/2023

TYPICAL WASTEWATER SERVICE  
INSTALLATION FOR VACUUM SEWER

PAGE NO.

87S

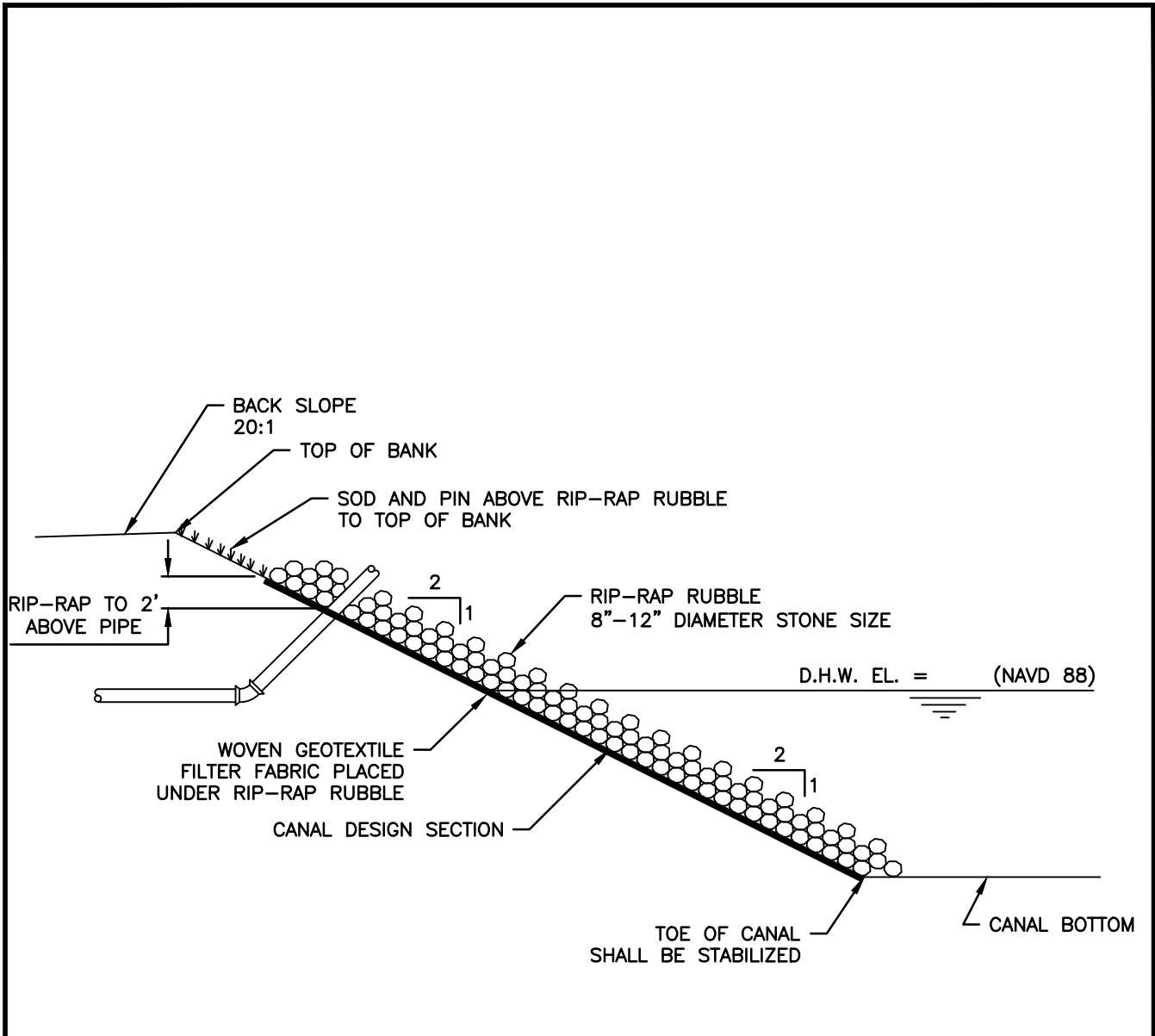

**NOTES:**

1. RIP-RAP RUBBLE AND ITS INSTALLATION MUST MEET CANAL OWNERSHIP SPECIFICATIONS AND PERMITTING REQUIREMENTS.
2. DUMP RUBBLE IN PLACE FORMING A COMPACT LAYER CONFORMING TO THE CANAL DESIGN SECTION SLOPE. ENSURE THAT RUBBLE DOES NOT SEGREGATE SO THAT SMALLER PIECES EVENLY FILL THE VOIDS BETWEEN LARGER PIECES.
3. AN ALTERNATIVE DESIGN WILL BE CONSIDERED AND MUST RECEIVE PRIOR APPROVAL FROM THE CANAL PROPERTY OWNER.

PALM BEACH COUNTY CONSTRUCTION STANDARDS & DETAILS

REVISION/ISSUE DATE

01/2023\*

RIP-RAP RUBBLE DETAIL (N.T.S.)

PAGE NO.

885\*



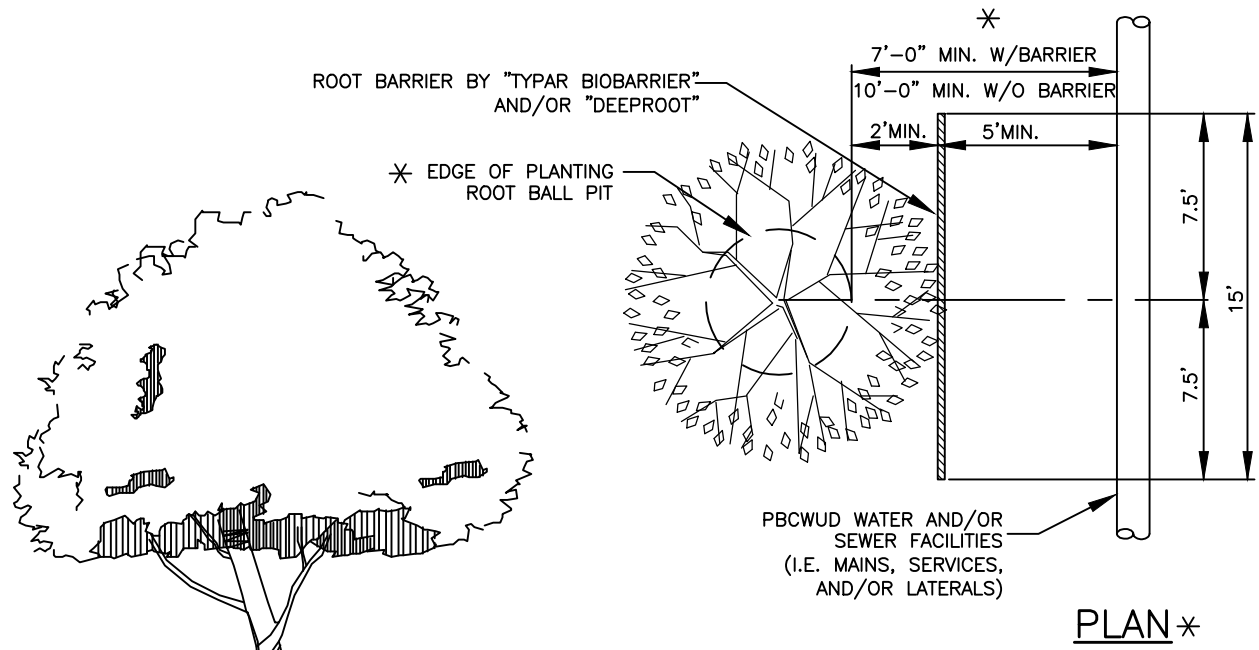

PLAN\*

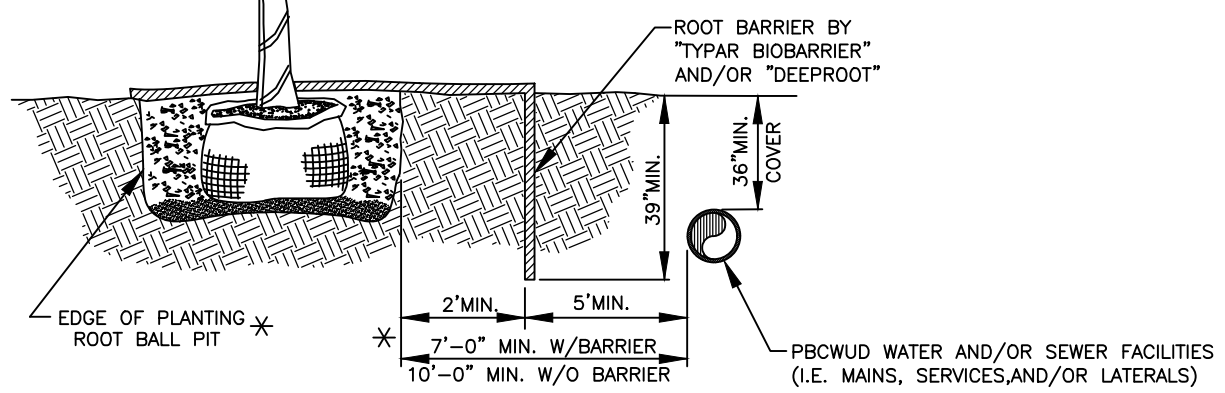

SECTION\*

NOTES:

1. TREES SHOWN ON THIS PLAN ARE FOR GRAPHIC REPRESENTATION ONLY. TREE SPACING IS BASED ON DESIGN REQUIREMENTS AND THE TREES SHOWN ON THESE PLANS ATTEMPT TO ACCOMPLISH THAT SPACING WHILE MAINTAINING THE REQUIRED SETBACKS FROM UTILITIES. TREES MAY BE FIELD ADJUSTED TO AVOID CONFLICTS WITH DRIVEWAYS AND UNDERGROUND UTILITIES. IN ANY CASE THE TREES SHALL BE LOCATED IN THE FIELD IN ACCORDANCE WITH THE PLANTING DETAILS SHOWN HEREON.
2. TREES ARE TO BE INSTALLED WITH A TEN FOOT (10') SEPARATION FROM ANY WATER OR SEWER MAIN AND/OR SERVICE, HYDRANTS, AND LIFT STATIONS. IF A TEN FOOT (10') SEPARATION CANNOT BE ACHIEVED, THE TREE CAN BE INSTALLED WITH A ROOT BARRIER SYSTEM. HOWEVER, IN NO CASE SHALL A TREE ENCROACH INTO A PBCUE WITHOUT PRIOR DEPARTMENT APPROVAL.

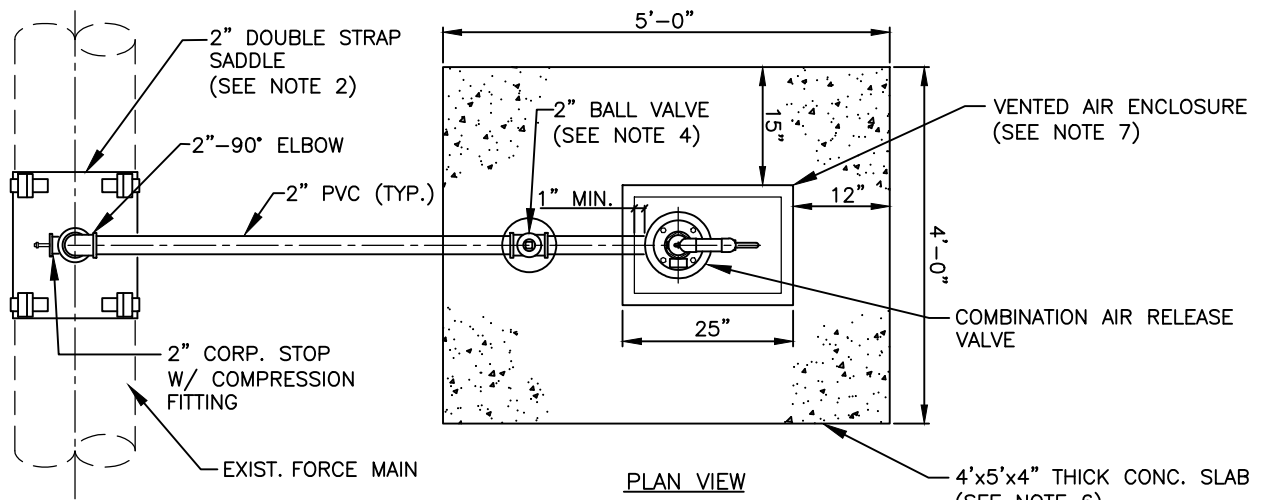

PLAN VIEW

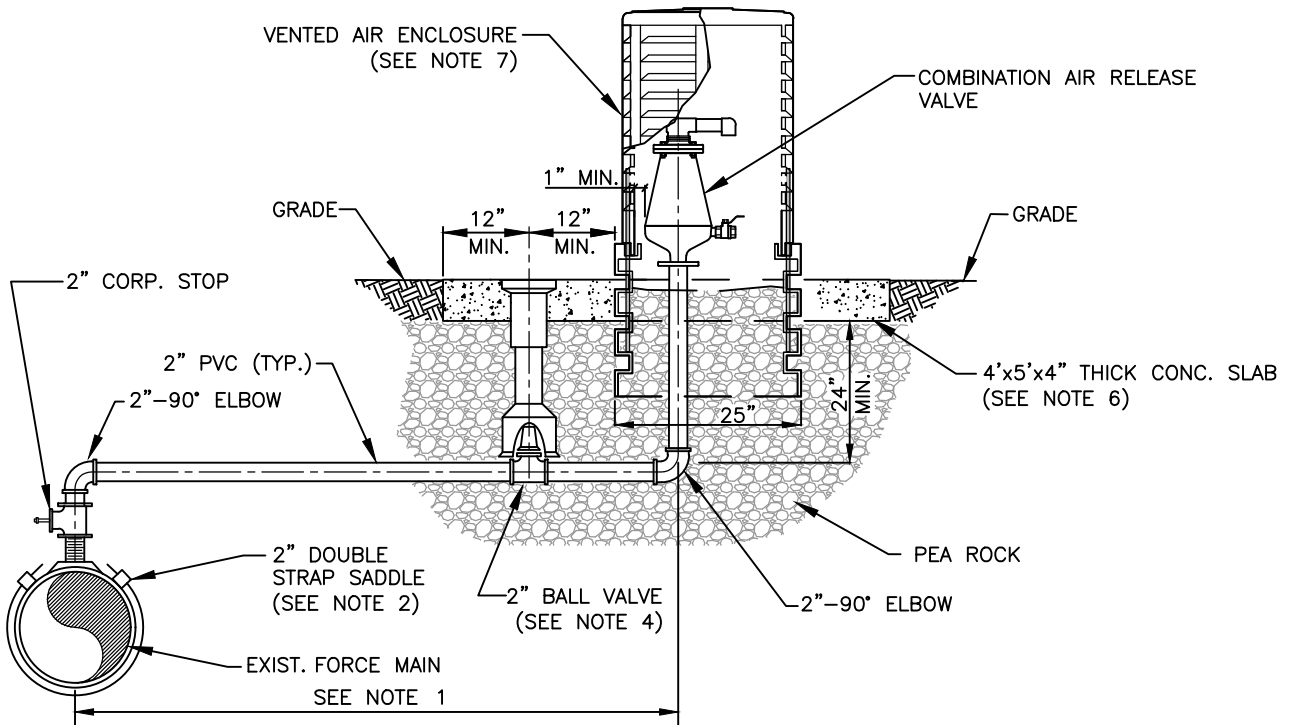

PROFILE VIEW

**NOTES:**

1. OFF-SET DISTANCE VARIES ON LOCATION OF FORCE MAIN TO ARV ENCLOSURE. IN NO CASE SHALL THE OFF-SET DISTANCE EXCEED 10' UNLESS OTHERWISE APPROVED BY THE DEPARTMENT PRIOR TO INSTALLATION.
2. 2" DOUBLE STRAP SADDLE TO BE INSTALLED PERPENDICULAR TO FORCE MAIN IN THE DIRECTION OF TOP.
3. ALL PVC PIPING AND FITTINGS TO BE SCHEDULE 80.
4. 2" BALL VALVE AND CORPORATION STOP SHALL BE BRASS WITH COMPRESSION FITTINGS ON EACH END.
5. ALL FITTINGS AND VALVES SHALL BE COMPRESSION TYPE.
6. CONCRETE PAD FOR WATER METER ASSEMBLY SHALL BE 4" THICK WITH WIRE MESH (4"x4") CONCRETE PAD IS REQUIRED TO BE BROOM FINISHED.
7. VENTED ENCLOSURE SHALL BE CHANNELL COMPANY #SPH1420, SEE APPROVED MATERIALS AND EQUIPMENT LIST. ENCLOSURE SHALL BE CAPABLE OF ALLOWING THE SAME AMOUNT OF AIR FLOW AS THE ARV.
8. THIS FORCE MAIN OFF-SET ARV REQUIRES PREVIOUS DEPARTMENT APPROVAL PRIOR TO INSTALLATION.

PALM BEACH COUNTY CONSTRUCTION STANDARDS & DETAILS

REVISION/ISSUE DATE  
01/2023\*

FORCE MAIN AIR RELEASE VALVE  
W/ VENTED AIR ENCLOSURE

PAGE NO.  
90S\*

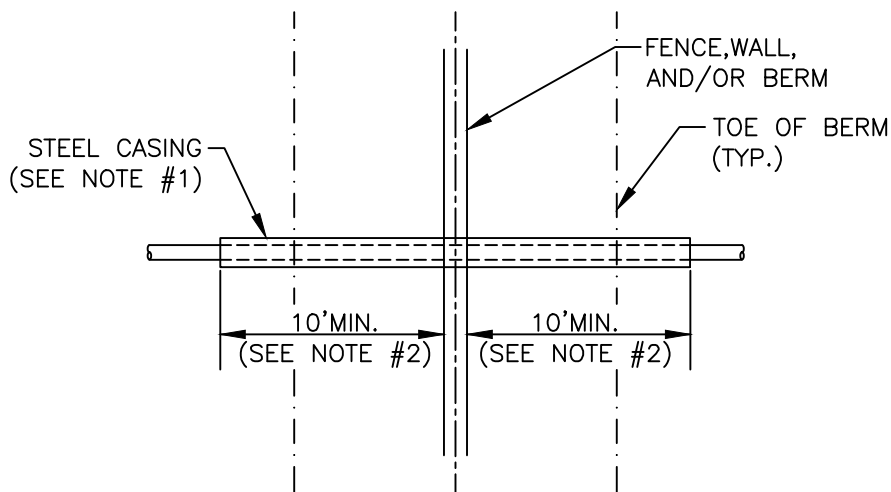

PLAN

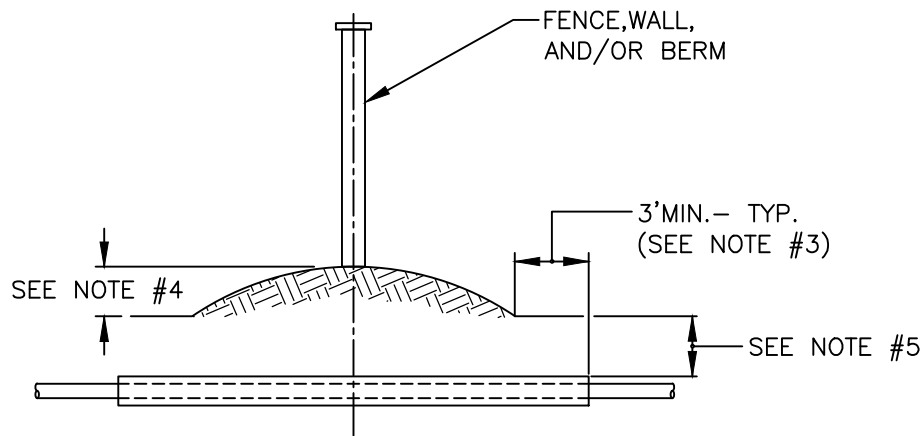

SECTION

NOTES:

1. STEEL CASING PER WUD STANDARD DETAIL 44S (SOLID CASING) OR WUD STANDARD DETAIL 44AS (SPLIT CASING) AS APPLICABLE.
2. STEEL CASING SHALL EXTEND TEN (10) FEET MINIMUM PAST FENCE OR WALL. FIVE (5) FEET MINIMUM MAY BE ACCEPTABLE ON A CASE-BY-CASE BASIS DUE TO SITE CONDITIONS AND ONLY WITH PRIOR DEPARTMENT APPROVAL.
3. STEEL CASING SHALL EXTEND THREE (3) FEET MINIMUM PAST THE TOE OF THE BERM. IF BERM CASING IS ASSOCIATED WITH A WALL OR FENCE INSTALLATION OF THE CASING SHALL EXTEND THREE (3) FEET MINIMUM PAST THE TOE OF THE BERM OR TEN (10) FEET MINIMUM PAST THE WALL OR FENCE WHICH EVER IS GREATER.
4. STEEL CASING INSTALLATION REQUIRED WHEN A BERM IS TWO (2) FEET OR HIGHER ABOVE SURROUNDING GRADE.
5. TOP OF STEEL CASING SHALL BE THREE (3) FEET MINIMUM BELOW THE TOE OF THE BERM OR BASE OF WALL OR FENCE ELEVATION WHICHEVER IS LOWER.

PALM BEACH COUNTY CONSTRUCTION STANDARDS & DETAILS

REVISION/ISSUE DATE

01/2023\*

WASTEWATER MAIN CROSSING  
FENCE, WALL, OR BERM CASING DETAIL\*

PAGE NO.

91S\*

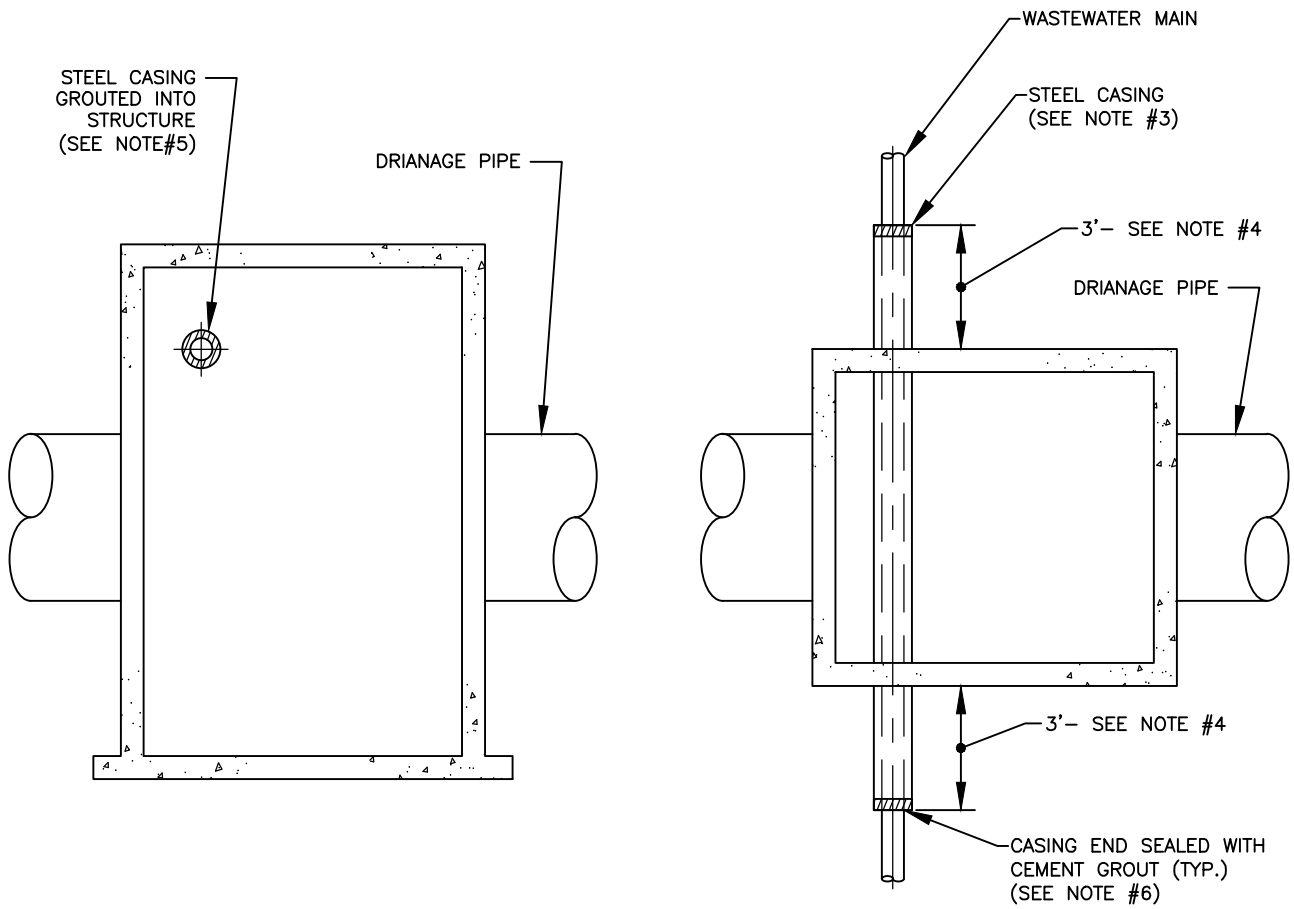

PROFILE

PLAN

WUD MAIN SIZE	DIAMETER OF STEEL CASING SIZE	OPENING SIZE FOR SOLID CASING	OPENING SIZE FOR SPLIT CASING
6"	14"	18"	20"
8"	20"	24"	26"
10"	20"	24"	26"
12"	24"	28"	30"

NOTES:

1. THE CONFLICT STRUCTURE IS TO BE DESIGNED PER CURRENT FDOT UTILITY CONFLICT THRU DRAINAGE STRUCTURE STANDARDS.
2. A SHOP DRAWING TO SCALE FOR EACH CONFLICT STRUCTURE INSTALLATION IS REQUIRED TO BE APPROVED BY THE DEPARTMENT PRIOR TO INSTALLATION.
3. STEEL CASING PER WUD STANDARD DETAIL 44S (SOLID CASING) OR WUD STANDARD DETAIL 44AS (SPLIT CASING) FOR EXISTING WASTEWATER MAIN ONLY.
4. STEEL CASING SHALL EXTEND THREE (3) FEET PAST EACH SIDE OF STRUCTURE. CASING CAN EXTEND FURTHER PAST THE STRUCTURE WHEN EXISTING CONDITIONS WARRANT AND ONLY PRIOR TO DEPARTMENT APPROVAL.
5. STEEL CASING SHALL BE GROUTED IN PLACE WITH NON-SHRINKABLE CEMENT GROUT TO PROVIDE A WATERTIGHT SEAL TO PREVENT ANY LEAKAGE INTO THE STRUCTURE.
6. NON-SHRINKABLE CEMENT GROUT TO BE INSTALLED AT EACH END OF CASING TO OBTAIN WATERTIGHT SEAL.
7. 16" AND LARGER WASTEWATER MAINS REQUIRING A CONFLICT STRUCTURE WILL BE CONSIDERED BY THE DEPARTMENT ONLY WHEN EXTREME CIRCUMSTANCES EXIST WHEN THE MAIN CANNOT BE DEFLECTED AROUND THE DRAINAGE PIPE.

PALM BEACH COUNTY CONSTRUCTION STANDARDS & DETAILS

REVISION/ISSUE DATE

01/2023\*

WASTEWATER MAIN CONFLICT  
STRUCTURE DETAIL\*

PAGE NO.

92S\*